

# PALMGREN<sup>®</sup>

## 10" BENCH TOP BAND SAW



*Read carefully and follow all safety rules and operating instructions before first use of this product.*

## GETTING STARTED

### STRUCTURAL REQUIREMENTS

Make sure all supporting structures and load attaching devices are strong enough to hold your intended loads. If in doubt, consult a qualified structural engineer.

### ELECTRICAL REQUIREMENTS

The power supply to the Band Saw needs to be 120 volt/ 3.5 amp, single phase, 60 Hz. The standard allowable voltage variation is plus or minus 10%.

### TOOLS NEEDED:

Standard mechanic's hand tool set.

## UNPACKING

**WARNING:** Be careful not to touch overhead power lines, piping, lighting, etc. if lifting equipment is used. Band Saw weighs approximately 77 lbs, proper tools, equipment and qualified personnel should be employed in all phases of unpacking and installation.

Carton should be handled with care to avoid damage from dropping, bumping, etc. Store and unpack carton with correct side up. After unpacking Band Saw, inspect carefully for any damage that may have occurred during transit. Check for loose, missing or damaged parts. If any damage or loss has occurred, claim must be filed with carrier immediately. Check for completeness. Immediately report missing parts to dealer.

Band Saw is shipped partially assembled. End user will need to assemble loose parts to machine.

**IMPORTANT:** The tool has been coated with a protective coating. In order to ensure proper fit and operation, the coating must be removed. Remove coating with mild solvents such as mineral spirits and a soft cloth. Nonflammable solvents are recommended. After cleaning, cover all exposed metal surfaces with a light coating of oil. Paste wax is recommended for table top.

**CAUTION:** Never use highly volatile solvents. Avoid getting cleaning solution on paint as it may tend to deteriorate these finishes. Use soap and water on painted components.

### CONTENTS:

- Band Saw (1)
- Table (1)
- Guide rail (1)
- Rip fence with knob (1)
- Miter gauge assembly (1)
- Pushstick (1)
- Hardware bag (1) - Includes: M6 x 30 hex head bolt and nut; four each hex bolts and M6 serrated washers; four each wing nut bolts and washers.
- Operating Instructions and Parts Manual (1)

### UNPACK:

Do not discard packing materials until after machine has been inspected for damage and completeness. Locate loose parts and set aside.

### INSPECT:

After unpacking the unit, carefully inspect for any damage that may have occurred during transit. Check for loose, missing or damaged parts. Shipping damage claims must be filed with the carrier.

All tools should be visually inspected before use, in addition to regular periodic maintenance inspections.

Be sure that the voltage labeled on the unit matches your power supply.

## SAFETY RULES

**WARNING:** For your own safety, read operating instructions manual before operating tool.

**PROPOSITION 65 WARNING:** Some dust created by using power tools contain chemicals known to the state of California to cause cancer, birth defects or other reproductive harm.

Some examples of these chemicals are:

- Lead from lead-based paints
- Crystalline silica from bricks and cement and other masonry products.
- Arsenic and chromium from chemically treated lumber.

Your risk from these exposures varies, depending on how often you do this type of work. To reduce your exposure to these chemicals; work in a well ventilated area and work with approved safety equipment. Always wear **OSHA/NIOSH** approved, properly fitting face mask or respirator when using such tools.

**WARNING:** Always follow proper operating procedures as defined in this manual even if you are familiar with the use of this or similar tools. Remember that being careless for even a fraction of a second can result in severe personal injury.

### BE PREPARED FOR JOB

- Wear proper apparel. Do not wear loose clothing, gloves, neckties, rings, bracelets or other jewelry which may get caught in moving parts of machine.
- Wear protective hair covering to contain long hair.
- Wear safety shoes with non-slip soles.
- Wear safety glasses complying with United States ANSI Z87.1. Everyday glasses have only impact resistant lenses. They are **NOT** safety glasses.
- Wear face mask or dust mask if operation is dusty.
- Be alert and think clearly. Never operate power tools when tired, intoxicated or when taking medications that cause drowsiness.

### PREPARE WORK AREA FOR JOB

- Keep work area clean. Cluttered work areas invite accidents.
- Do not use power tools in dangerous environments. Do not use power tools in damp or wet locations. Do not expose power tools to rain.
- Work area should be properly lighted.
- Proper electrical receptacle should be available for tool. Three-prong plug should be plugged directly into properly grounded, three-prong receptacle.
- Extension cords should have a grounding prong and the three wires of the extension cord should be of the correct gauge.
- Keep visitors at a safe distance from work area.
- Keep children out of workplace. Make workshop childproof. Use padlocks, master switches or remove switch keys to prevent any unintentional use of power tools.

**SAFETY RULES (CONTINUED)**

**TOOL SHOULD BE MAINTAINED**

- Always unplug tool prior to inspection.
- Consult manual for specific maintaining and adjusting procedures.
- Keep tool lubricated and clean for safest operation.
- Remove adjusting tools. Form habit of checking to see that adjusting tools are removed before switching machine on.
- Keep all parts in working order. Check to determine that the guard or other parts will operate properly and perform their intended function.
- Check for damaged parts. Check for alignment of moving parts, binding, breakage, mounting and any other condition that may affect a tool's operation.
- A guard or other part that is damaged should be properly repaired or replaced. Do not perform makeshift repairs. (Use parts list provided to order repair parts.)

**KNOW HOW TO USE TOOL**

- Use right tool for job. Do not force tool or attachment to do a job for which it was not designed.
- Disconnect tool when changing the blade.
- Avoid accidental start-up. Make sure that the tool is in the OFF position before plugging in.
- Do not force tool. It will work most efficiently at the rate for which it was designed.
- Keep hands away from moving parts and cutting surfaces.
- Never leave tool running unattended. Turn the power off and do not leave tool until it comes to a complete stop.
- Do not overreach. Keep proper footing and balance.
- Never stand on tool. Serious injury could occur if tool is tipped or if blade is unintentionally contacted.
- Know your tool. Learn the tool's operation, application and specific limitations.
- Use recommended accessories. Use of improper accessories may cause risk of injury to persons.
- Handle workpiece correctly. Protect hands from possible injury.
- Turn machine off if it jams. Blade jams when it digs too deeply into workpiece. (Motor force keeps it stuck in the work.) Do not remove jammed or cut off pieces until the saw is turned off, unplugged and the blade has stopped.
- Maintain proper adjustment of blade tension, blade guides and thrust bearings.
- Adjust upper guide to just clear workpiece.
- Hold workpiece firmly against table.
- DIRECTION OF FEED: Feed work into a blade or cutter against the direction of rotation of the blade or cutter only.

**WARNING:** The operation of any power tool can result in foreign objects being thrown into the eyes, which can result in severe eye damage. Always wear safety goggles complying with United States ANSI Z87.1 before commencing power tool operation.

**CAUTION:** Think safety! Safety is a combination of operator common sense and alertness at all times when tool is being used.

**SPECIFICATIONS**

The Palmgren 10" Bench Top Band Saw features welded steel frame construction and a solid cast iron table surface to insure durability. It is designed for cutting hard and soft woods. The saw is equipped with a miter gauge for performing many different operations. A convenient quick tensioning and comprehensive tracking mechanism makes blade changing quick and easy. Saw also features a rip fence and dust collection port.

Depth of throat at 90° .....	9 1/2"
Maximum depth of cut at 90° .....	4"
Maximum depth of cut at 45° .....	2"
Table size .....	13 1/4" x 13 1/4"
Table tilt .....	0° to 45°
Wheel diameter .....	10"
Blade length .....	67 3/8"
Blade width .....	1/4" – 1/2"
Blade speed .....	2900 FPM
Motor .....	1/3 HP, 120V, 3.5 A, 60 Hz, 1725 RPM
Overall dimensions .....	21 x 16 1/2 x 34"
Weight .....	70 lbs
Shipping weight .....	77 lbs
Dust collection port .....	2 1/2"

**ASSEMBLY**

Refer to Figures 4, 5, 6 and 8.

**CAUTION:** Do not attempt assembly if parts are missing. Use this manual to order repair parts.

The machine is supplied partly assembled. Prior to use, the following items have to be installed: Table, Guide Rail, Rip Fence, Dust Collector (not included) and Rip Fence.

**WARNING:** o avoid injury, do not attempt to run or use this machine until all parts are assembled and working properly.

**ASSEMBLE TABLE TO TRUNNION**

Refer to Figure 1

Assemble the table on to the upper table trunnion, taking care when passing the saw blade through the slot of the table.

1. Attach M6 x 30 hex head bolt and nut (Stop Bolt) into hole next to the insert on table bottom.
2. Locate four hex bolts and four M6 serrated washers from the bag of loose parts. Mount the table to the upper table trunnion and install a bolt with washer in each hole, and then tighten with adjustable wrench.

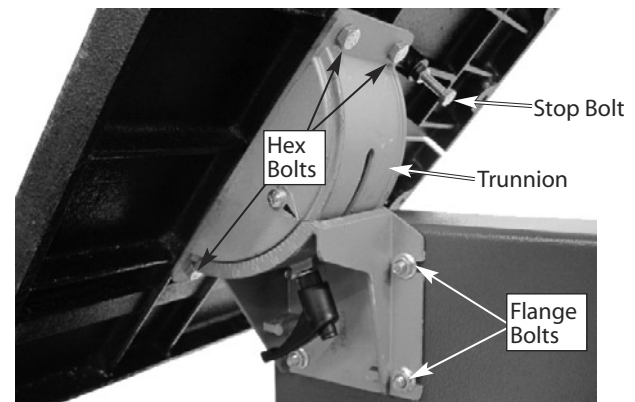

**Figure 1 - Assemble table to trunnion.**

**ASSEMBLY (CONTINUED)****CENTERING THE TABLE**

Refer to Figure 1.

1. Loosen the four hex bolts mounting the table to the upper table trunnion.
2. Move the table sideways as required, until the saw blade runs through the center of the table insert.
3. If moving the upper table trunnion is not enough to center the table, loosen the four flange nuts holding the lower table trunnion and move the table sideways to place the table in the center.
4. Re-tighten hex bolts for trunnion and flange nuts, recheck the saw blade position.

**SETTING TABLE SQUARE TO SAW BLADE**

Refer to Figures 2 and 3.

Loosen the knob on the lower table trunnion and place a suitably sized square against the saw blade. If the table requires adjustment, proceed as follows:

1. Using a wrench, release the hex nut on the bolt (see Figure 2). Place the wrench on the hex bolt and adjust until the table is square to the saw blade.

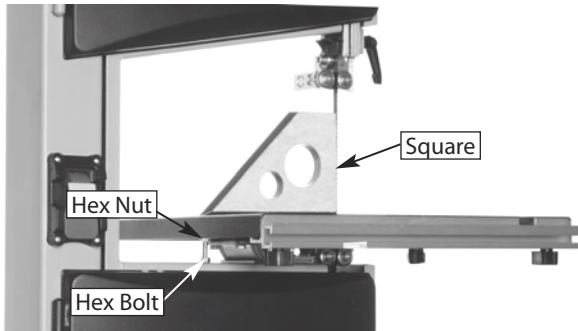

**Figure 2 - Square table to saw blade.**

2. Tighten the hex nut and recheck the saw blade and the table for squareness.
3. Lock the table into position and check that the indicator reads zero degree on the side of lower table trunnion. Loosen the screw securing the indicator and reset if necessary to give zero degree reading (see Figure 3).

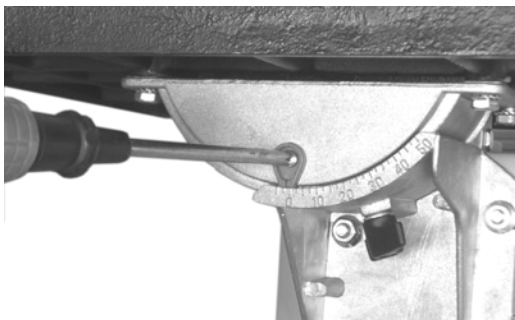
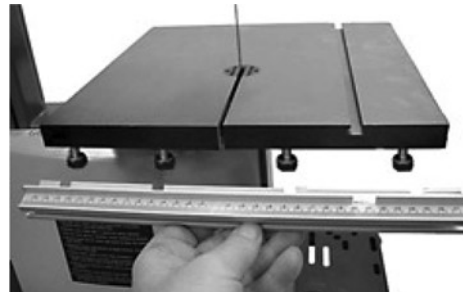

**Figure 3 - Set indicator to zero.**

**FASTEN GUIDE RAIL**

Refer to Figure 4.

- Fasten the guide rail with four hex bolts and washers to the table.

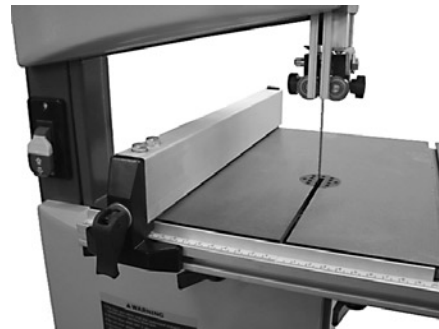

**Figure 4 - Fasten guide rail.**

**INSTALL RIP FENCE**

Refer to Figure 5.

- Lay the rip fence onto the guide rail. Adjust the rip fence parallel to the saw blade. Tighten rip fence handle by pressing downward.

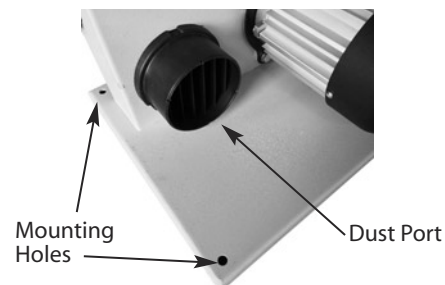

**Figure 5 - Install rip fence.**

**STABILIZE MACHINE**

Refer to Figure 6.

- To ensure sufficient upright stability of the machine it should be bolted to floor, bench or worktable. For this purpose 8mm holes are provided in the machine's base. Mounting hardware not provided.



**Figure 6- Mounting holes and dust port.**

**ASSEMBLY (CONTINUED)**

**USE SUITABLE DUST COLLECTOR**

Refer to Figure 6 and 8.

- The band saw has a dust port included that will accommodate 2 1/2" dust collection hoses.

It is recommended that when in use, the band saw is connected to a suitable dust collector.

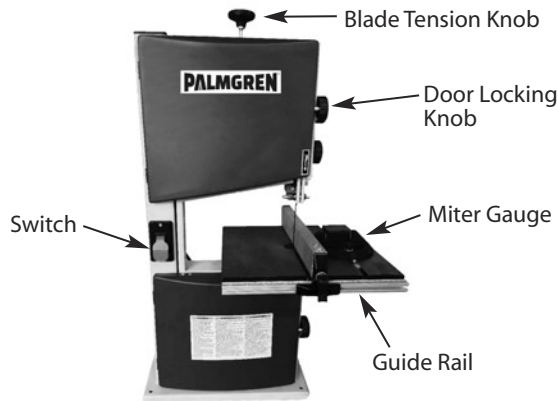

**Figure 7 - Know your band saw.**

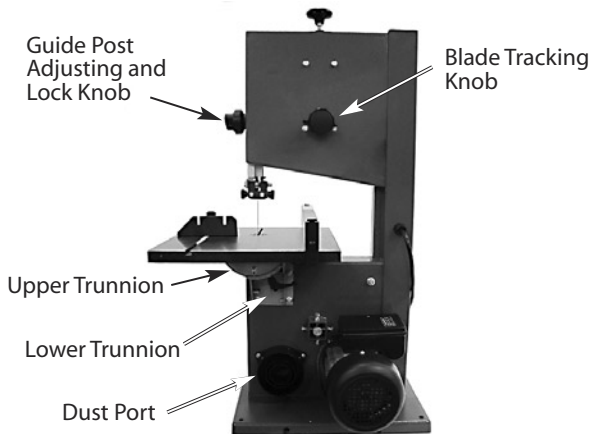

**Figure 8 - Know your band saw.**

**INSTALLATION**

**ELECTRICAL CONNECTIONS**

**WARNING:** All electrical connections must be performed by a qualified electrician.

**WARNING:** Make sure unit is off and disconnected from power source any time wiring is inspected.

**POWER SOURCE**

Band Saw is prewired for 120 volt, 60 HZ power source.

The motor is designed for operation on the voltage and frequency specified. Normal loads will be handled safely on voltages not more than 10% above or below the specified voltage.

Running the unit on voltages which are not within the range may cause overheating and motor burn-out. Heavy loads require that the voltage at motor terminals be no less than the voltage specified.

Power supply to the motor is controlled by a single pole toggle switch.

**GROUNDING INSTRUCTIONS**

**WARNING:** Improper connection of equipment grounding conductor can result in the risk of electrical shock. Equipment should be grounded while in use to protect operator from electrical shock.

- Check with a qualified electrician if grounding instructions are not understood or if in doubt as to whether the tool is properly grounded.

This tool is equipped with an approved 3-conductor cord rated at 150V and a three prong grounding type plug or your protection against shock hazards.

- Grounding plug should be plugged directly into a properly installed and grounded 3-prong grounding-type receptacle, as shown (Figure 9).

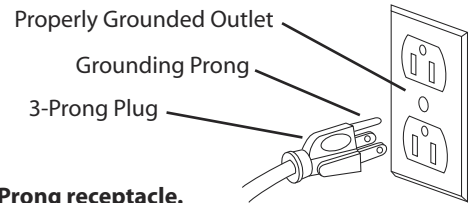

**Figure 9 – 3-Prong receptacle.**

- Do not remove or alter grounding prong in any manner. In the event of a malfunction or breakdown, grounding provides a path of least resistance for electrical shock.

**WARNING:** Do not permit fingers to touch the terminals of plug when installing or removing from outlet.

- Plug must be plugged into matching outlet that is properly installed and grounded in accordance with all local codes and ordinances. Do not modify plug provided. If it will not fit in outlet, have proper outlet installed by a qualified electrician.
- Inspect tool cords periodically, and if damaged, have repaired by an authorized service facility.
- Green (or green and yellow) conductor in cord is the grounding wire. If repair or replacement of the electric cord or plug is necessary, do not connect the green (or green and yellow) wire to a live terminal.

Where a 2-prong wall receptacle is encountered, it must be replaced with a properly grounded 3-prong receptacle installed in accordance with National Electric Code and local codes and ordinances.

**WARNING:** This work should be performed by a qualified electrician.

A temporary 3-prong to 2-prong grounding adapter (see Figure 10) is available for connecting plugs to a two pole outlet if it is properly grounded.

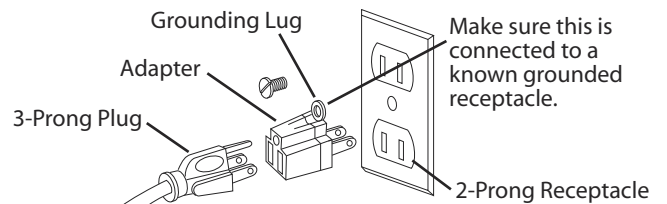

**Figure 10 – 2-Prong receptacle with adapter.**

- Do not use a 3-prong to 2-prong grounding adapter unless permitted by local and national codes and ordinances. (A 3-prong to 2-prong grounding adapter is not permitted in Canada.) Where permitted, the rigid green tab or terminal on the side of the adapter must be securely connected to a permanent electrical ground such as a properly grounded water pipe, a properly grounded outlet box or a properly grounded wire system.

## INSTALLATION (CONTINUED)

Many cover plate screws, water pipes and outlet boxes are not properly grounded. To ensure proper ground, grounding means must be tested by a qualified electrician.

## EXTENSION CORDS

- The use of any extension cord will cause some drop in voltage and loss of power.
- Wires of the extension cord must be of sufficient size to carry the current and maintain adequate voltage.
- Running the unit on voltages which are not within  $\pm 10\%$  of the specified voltage may cause overheating and motor burn-out.
- Use the table to determine the minimum wire size (A.W.G.) extension cord.
- Use only 3-wire extension cords having 3-prong grounding type plugs and 3-pole receptacles which accept the tool plug.
- If the extension cord is worn, cut or damaged in any way, replace it immediately.

Extension Cord Table						
		Volts	Total Length of Cord in Feet			
Ampere Rating		120	25	50	100	150
More Than	Not More Than	240	50	100	150	300
		Minimum Gage for Cord				
0	6		18	16	16	14
6	10		18	16	14	12
10	12		16	16	14	12
12	16		14	12	Not Recommended	

**WARNING:** This machine must be grounded. To avoid electrocution or fire, any repairs to electrical system should be done only by a qualified electrician, using genuine replacement parts.

## OPERATION

### SAFETY PRECAUTIONS

**WARNING:** Always observe the following safety precautions.

- Whenever adjusting or replacing any parts on the band saw turn, switch off and remove plug from power source.
- Make sure the blade guides are positioned correctly.
- Use the appropriate blade for the workpiece that is being cut.
- Use a sharp blade. Replace dull blades or blades which are missing teeth.
- Make sure the blade is tensioned properly and going in the right direction.
- Use the proper blade speed for the work.
- For optimum performance, do not stall the motor or reduce the speed. Use the proper feed pressure.
- Secure the workpiece in a stable position.
- Check that all guards are attached.
- After turning the switch on, let the blade come to full speed.
- Keep hands away from the blade and all moving parts.
- Always wear eye protection or face shield.
- Always stop the band saw before removing scrap pieces from table.
- Never attempt to saw stock that does not have a flat surface, unless a suitable support is used.
- Always hold material firmly and feed it into the blade at a moderate speed.
- Always turn off the machine if the material is to be backed out of an uncompleted cut.

- Make sure that the blade tension and blade tracking are properly adjusted.
- Make "relief" cuts before cutting long curves.
- Release blade tension when the saw will not be used for a long period of time.

## ON/OFF SWITCH

Refer to Figure 11.

**WARNING:** Before starting check if any part of your band saw is missing, malfunctioning, has been damaged or broken, such as the motor switch, or other operation control, a safety device or the power cord, turn the band saw off and unplug it until the particular part is properly repaired or replaced.

The ON/OFF switch is located on the left front of the saw column. To turn saw ON, pull the switch to the up position. To turn saw OFF, push the switch to the down position.

The saw can be locked from unauthorized use by locking the switch. To lock the switch:

1. Turn the switch to OFF position and disconnect saw from power source.
2. Pull the key out. The switch cannot be turned on with the key removed.

**NOTE:** Should the key be removed from the switch at the ON position, the switch can be turned off but cannot be turned on again.

- To replace key, slide key into the slot on switch until it snaps.

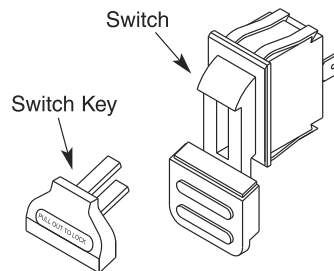

Figure 11 - ON/OFF Switch and Key

## ADJUSTMENTS

The blade tracking, tension and blade guides have been properly adjusted at the factory. However, the adjustments may change while the saw is in transit.

It is recommended to verify these adjustments before operating saw.

## CHANGING AND ADJUSTING THE SAW BLADE

This band saw is factory-equipped with a general-purpose wood cutting blade; the saw blade is set prior to delivery.

To change the saw blade, the following procedure must be followed:

**WARNING:** To avoid injury from unexpected starting, whenever changing the saw blade or carrying out adjustments, switch the band saw off and remove the power cord from the main outlet. To avoid injury to hands when handling the saw blade, wear gloves whenever necessary.

1. Remove the rip fence, the guide rail, the wing nut and screw from the table.
2. Open the upper and lower doors by turning the door locking knobs.
3. Loosen the tracking lock knob (See figure 13, page 9).

**OPERATION (CONTINUED)**

- Loosen the blade tension by turning the blade tension knob on the top of the upper wheel housing counterclockwise until the saw blade has slackened (viewed from above). See Figure 12.

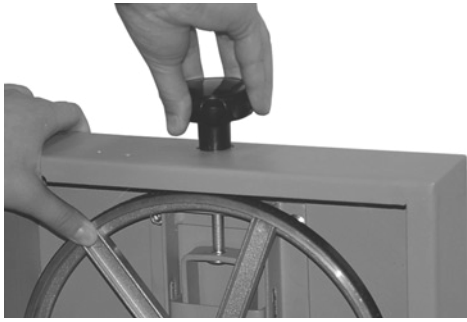

**Figure 12 - Blade Tension Knob**

- Remove the saw blade from the upper and lower wheels. When fitting the new saw blade ensure the blade teeth are pointing downwards and towards you at the position where the saw blade passes through the table.

- Re-tension the new saw blade and check the saw blade tracking by turning the upper wheel by hand.

The saw blade should run in the center of the band saw wheels. If needed adjust the tracking of the saw blade, follow procedures for "Tracking the Saw Blade".

- Tighten the tracking lock knob.
- Replace the rip fence, the guide rail, the wing nut and screw to the table.
- Close the upper and lower doors by turning the door locking knobs before reconnecting the power supply.

**TRACKING THE SAW BLADE**

Refer to Figure 13.

Set the tracking of the saw blade before setting the blade guides.

- Once the saw blade is installed and tensioned, track the saw blade by adjusting the tracking knob by hand.
- The saw blade should run in the center of the band saw wheels.
- When the correct adjustment is achieved lock the tracking knob with the tracking lock knob.

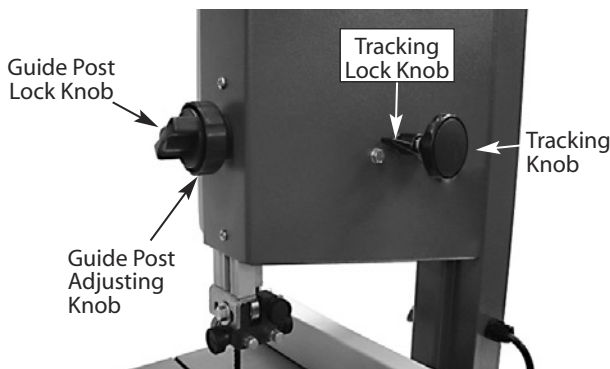

**Figure 13 - Set tracking of saw blade.**

**SETTING THE CUTTING HEIGHT**

Refer to Figure 13.

The upper blade guide should be set as close as practical against the workpiece.

- To adjust this height, loosen the guide post lock knob at the side of the upper wheel housing.

- Set the blade guide to the required height by turning the guide post adjusting knob.
- Tighten guide post locking knob after setting.

**ALIGNING THE UPPER BLADE GUIDE**

The upper blade guide consists of:

- A thrust bearing (supporting the band saw blade from the rear).
- Two guide bearings (providing lateral support).

All bearings need to be readjusted after every band saw blade change and/or tracking adjustment.

**NOTE:** Periodically check all bearings for wear, if necessary replace both guide bearings at the same time.

**ADJUSTING THE THRUST BEARING**

Refer to Figure 14.

- If necessary, align and tighten the band saw blade.
- Loosen fixing screw of the upper blade guide.
- Align upper blade guide
- Tighten the upper blade guide's fixing screw.
- Loosen the thrust bearing's lock screw.
- Adjust thrust bearing position (distance thrust bearing - band saw blade = 0.5 mm – if the band saw blade is turned by hand, it must not touch the thrust bearing).
- Tighten the thrust bearing lock screw.

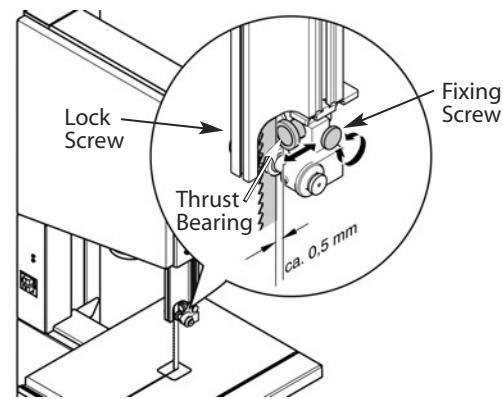
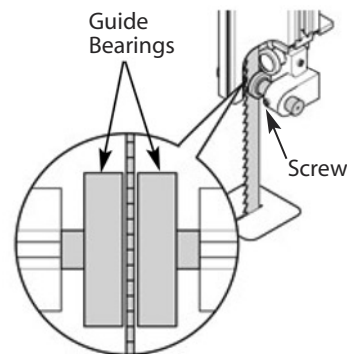

**Figure 14 - Adjusting the thrust bearings.**

**ADJUSTING THE GUIDE BEARINGS**

Refer to Figure 15.

- Loosen the bearing's lock screw.
- Set guide bearings with the screws against the band saw blade.
- Turn band saw wheel by hand in a clockwise direction several times to bring the guide bearings in correct position – both guide bearings should just touch the band saw blade.
- Tighten the bearing's lock screw.



**Figure 15 - Adjusting the guide bearings.**

**OPERATION (CONTINUED)****ALIGNING THE LOWER BLADE GUIDE**

The lower blade guide consists of:

- A thrust bearing (supporting the band saw blade from the rear).
- Two guide bearings (providing lateral support).

These parts need to be readjusted after every band saw blade change or tracking adjustment:

**NOTE:** Periodically check thrust bearings and guide bearings for wear, if necessary replace both guide bearings at the same time.

**BASIC ALIGNMENT**

Refer to Figures 16 through 18.

1. Open the lower housing door.
2. Loosen lower blade guide fixing-screw with an open jaw wrench.
3. Adjust position of lower blade guide until band saw blade is centered between the guide bearings.
4. Tighten fixing-screw.

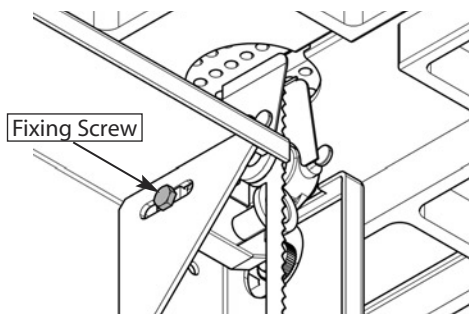
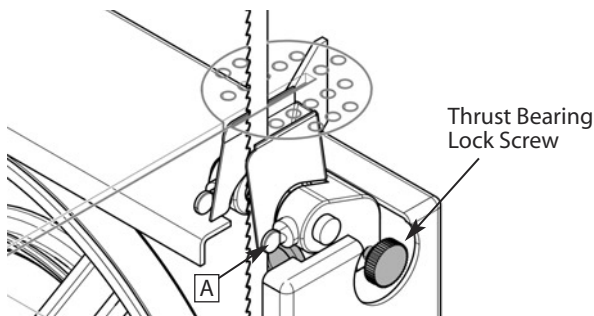

**Figure 16 - Basic alignment.**

**ADJUSTING THE THRUST BEARING**

Refer to Figure 17.

1. Loosen the thrust bearing's lock screw.
2. Adjust thrust bearing position (A) (distance thrust bearing - band saw blade = 0.5 mm – if the band saw blade is turned by hand, it must not touch the thrust bearing).
3. Tighten the thrust bearing lock screw.

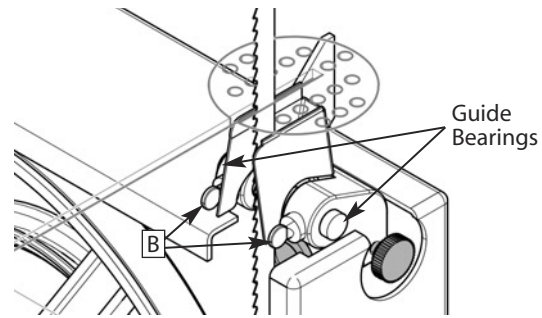

**Figure 17 - Basic alignment.**

**ADJUSTING THE GUIDE BEARINGS**

Refer to Figure 18.

1. Loosen screws (B).
2. Set guide bearings against the band saw blade.
3. Turn the band saw wheel by hand in a clockwise direction several times to bring the guide bearings in correct position – both guide bearings should just touch the band saw blade.
4. Tighten screws (B) again.
5. Close the lower housing door.

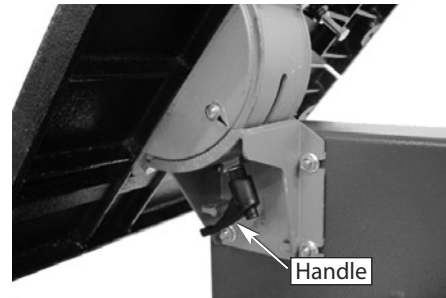

**Figure 18 - Basic alignment.**

**TILTING THE TABLE**

For bevel cuts, the table tilts 0 through 45 degrees.

1. To tilt the table, loosen the handle on the table trunnion, set the table to the required angle and tighten the handle again (see Figure 19).
2. It is recommended to verify the correct angle setting using an angle guide, or by making trial cuts in scrap wood. Adjust the indicator accordingly by using a Phillips head screwdriver.



**Figure 19 - Tilting the table.**

**ADJUSTING THE RIP FENCE**

Refer to Figure 20.

The locking pressure of the rip fence has been factory set; if adjustment is required proceed as follows:

1. Raise the fence handle to horizontal position.
2. Turn the fence handle clockwise to increase clamping pressure, counterclockwise to decrease clamping pressure.
3. After turning the fence handle counterclockwise, slide the rip fence to the desired position on the guide rail.
4. The fence handle has a cam action, press down the handle to clamp tightly to the table after setting rip fence to desired position.

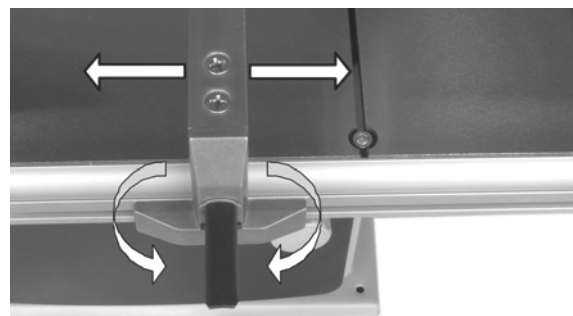

**Figure 20 - Adjusting the rip fence.**



**OPERATION (CONTINUED)**

NOTE: Do not adjust the fence handle such that excessive pressure is exerted during operation - this may lead to deformation of the end clamp at the rear of the rip fence. Set the fence handle to apply just enough pressure to secure fence position during cutting

**BLADE SELECTION**

- Blades vary depending on type of material, size of workpiece and type of cut that is being performed.
- Characteristics which make blades different are width, thickness and pitch.

**BLADE WIDTH**

- Width of blade describes distance from tip of a tooth to back of blade.
- Width of blade affects rigidity of blade. A wider blade wanders less and produces a straighter cut.
- Width of blade also limits the smallest radius which can be cut. A 1/4" wide blade can cut about a 1/2" radius.

**BLADE THICKNESS**

- Blade thickness describes the distance between sides of blade. A thicker blade has more rigidity and stronger teeth.
- A narrow thick blade is used to cut curves while a wide thin blade is used to make long, straight cuts.

**BLADE PITCH**

- Pitch describes number of teeth per inch or tooth size. A blade with more teeth per inch produces a smoother cut.
- The type of material being cut determines number of teeth which should be in contact with work.
- For soft materials, the proper blade has between 6 to 8 teeth per inch.
- When cutting hard materials, where shocking is more detrimental, use a blade with 8 to 12 teeth per inch.
- There should always be at least three teeth in contact with cut to avoid shocking blade.
- Blade shocking occurs when pitch is too large and blade tooth encounters too much material. This can strip teeth from blade.
- Blade manufacturers are prepared to supply information about blades for specific applications.

**TYPE OF CUT**

- Contour cutting is done by guiding workpiece freehanded to produce curved shapes.
- Beveled cutting is done by tilting saw table and using proper work guide method.
- Regardless of which work guiding method is used, a workpiece which overhangs table by more than 5" needs proper support.

**CONTOUR SAWING**

- When contour sawing, use both hands to keep workpiece flat against table and guided along desired path.
- Avoid positioning hands in line with blade. If hands slip, they could contact blade.
- Try to stand to front of the saw and use hands over the portion of table which is to right of blade and before cut.
- Cut small corners by sawing around them. Saw to remove scrap until desired shape is obtained.

**BEVEL CUTTING**

Perform bevel cutting by tilting table to desired degree.

1. Unlock table by loosening locking handle located on the backside of the unit.
2. Tilt table to desired position.
3. Lock table in position by tightening locking handle.

**MITER GAUGE**

Use miter gauge for securing and holding workpiece at desired angle to produce angled cuts. Use scale to adjust gauge to desired angle.

**WARNING:** Never use miter gauge and rip fence at the same time. The blade might bind in the workpiece. Operator could be injured and/or workpiece could be damaged.

**BLADE CLEANING BRUSH**

Make sure that brush (located in the lower housing) is in contact with blade to properly remove foreign particles from drive wheel.

**PUSH STICK**

The push stick protects against accidental contact with the saw blade.

- Always use the push stick when the distance between the saw blade and rip fence is less than 5 inches.
- Hold the push stick at an angle of 25-30 degrees to the table surface and guide workpiece through the blade.

## MAINTENANCE

Steps required to keep the saw in optimum operating condition have been described under "Operating Instructions." The Safety Precautions should be performed before operation.

For proper maintenance:

- Keep saw clean and dry. Sweep off spots where chips have collected.
- Lubricate the unpainted surfaces with a light application of medium consistency machine oil to prevent corrosion after cleaning.
- Replace dull blades and blades from which teeth have been stripped. A clean saw with a sharp blade will yield the best cut.
- Internal parts of the band saw have been completely lubricated at the factory and do not need to be relubricated.

**WARNING:** Make certain that the saw is disconnected from the power source before attempting to service or remove any component.

**WARNING:** Any attempt to repair the motor may create a hazard unless repair is done by qualified service technician.

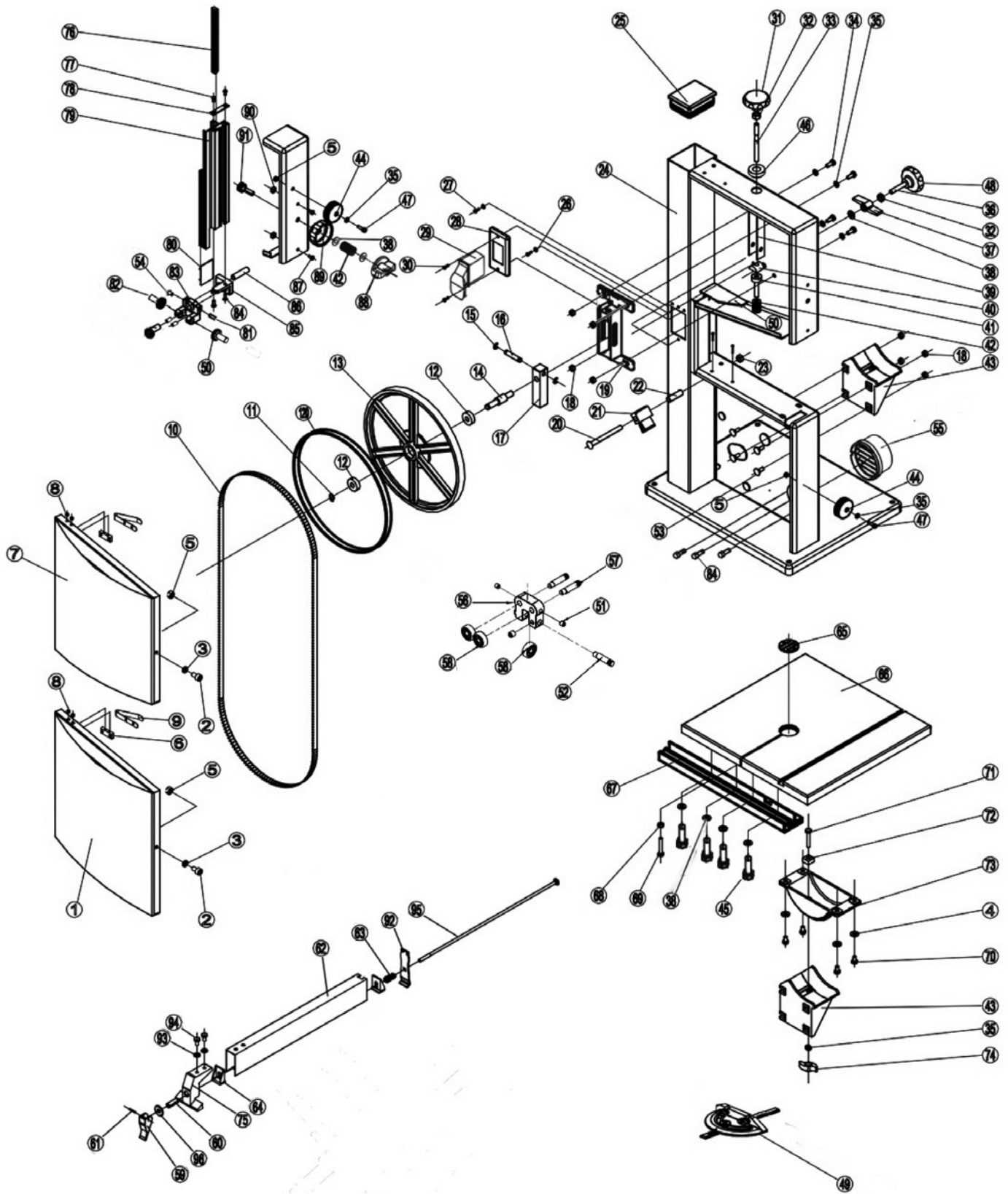

Figure 21 - Replacement parts illustration for 10" Bench Top Band Saw.

**REPLACEMENT PARTS LIST OR 10" BENCH TOP BAND SAW.**

Ref. No.	Description	Part No.	Qty.	Ref. No.	Description	Part No.	Qty.
1	Lower Door	9642921.01	1	49	Angle Gauge	9642953.01	1
2	Hex Socket Head Bolt M6 × 16	*	2	50	Bearing 625-2Z	*	3
3	Spacer Bushing	9642922.01	2	51	Hex Socket Set Screw M6 × 8	*	3
4	Serrated Lock Washer M6	*	4	52	Support Axle	9642956.01	1
5	Locking Nut M6	*	6	53	Cup Square Neck Bolt M6 × 16	*	4
6	Joining Block	9642923.01	2	54	Int. Head Screw M6 × 6	9642957.01	1
7	Upper Door	9642924.01	1	55	Dust Outlet	9642958.01	1
8	Pan Head Screw M4 × 16	*	4	56	Lower Guide	9642959.02	1
9	Spring Plate	9642925.01	2	57	Eccentric Guide Shaft	9645950.01	2
10	Saw Blade	9642926.01	1	58	Bearing 627-2Z	*	3
11	Ring Retaining	9642927.01	2	59	Fence Handle	9645951.01	1
12	Ball Bearing 6000-ZZ	*	4	60	Tension Bracket	9645952.01	1
13	Upper Wheel	9642928.01	1	61	Roll Pin 3 × 16	9642964.01	1
14	Bearing Bolt Upper	9642929.01	1	62	Rip Fence Ext.	9642965.01	1
15	Ring Retaining	9642930.01	2	63	Spring	9645953.01	1
16	Pin Guide	9642931.01	1	64	Locking Pad	9645954.01	2
17	Seat Bearing Bolt Upper	9642932.01	1	65	Table Insert	9642968.01	1
18	Hex Head Flange Nut M6	*	8	66	Work Table	9642969.01	1
19	Guide Plate Assembly	9642933.01	1	67	Rip Fence Carrier Extrusion	9642970.01	1
20	Cup Square Neck Bolt	9642934.01	1	68	Hex Head Nut M6	*	5
21	Brush Strip	9642935.01	1	69	Hex Head Bolt M6 × 30	*	1
22	Spacer Bushing	9642936.01	1	70	Hex Head Bolt M6 × 12	*	4
23	Hex Head Flange Nut M8	*	1	71	Cup Square Neck Bolt M6 × 50	*	1
24	Frame	N/A	1	72	Guide Piece	9642971.01	1
25	Lamello Plug Black	9642938.01	1	73	Table Trunnion Upper	9642972.01	1
26	Serrated Lock Washer M4	*	4	74	Locking Knob	9642973.01	1
27	Pan Head Screw M4 × 8	*	2	75	Fence Bracket	9645955.01	1
28	Switch Plate	9642939.01	1	76	Rack	9642975.01	1
29	Switch	9642940.01	1	77	Pan Head Tapping Screw ST.3.5	*	2
30	Countersunk HD. Screw M4 × 12	*	2	78	Cover Board	9642976.01	1
31	Tighten Handle	9642941.01	1	79	Guide Lever	9642977.01	1
32	Hex Head Nut M8	*	2	80	Slide Board	9642978.01	1
33	Thread Bolt	9642942.01	1	81	Int. Head Screw M6 × 8	*	3
34	Hex Head Bolt M6 × 16	*	4	82	Thrust Bearing Shaft	9645956.01	3
35	Washer M6	*	9	83	Three Roller Guide Housing	9642981.01	1
36	Hex Head Bolt M8 × 45	*	1	84	Pan Head Tapping Screw ST. 4.2	*	5
37	Wing Knob	9642943.01	1	85	Seat Guide Upper	9642982.01	1
38	Washer M8	*	8	86	Fastening Shaft	9642983.01	1
39	Blade Tensioner	9642944.01	1	87	Pan Head Tapping Screw ST 4.2	*	2
40	Nut	9642945.01	1	88	Lock Button Assembly	9642984.01	1
41	Shaft	9642946.01	1	89	Adjust Knob	9642985.01	1
42	Butterfly Spring	9642947.01	18	90	Guide Piece	9642986.01	2
43	Blade Trunnion Lower	9642948.01	1	91	Shaft	9642987.01	1
44	Dook locker	9642949.01	2	92	Clamp Board	9645957.01	2
45	Hex Head Bolt M8 × 12	*	4	93	Washer M6	*	2
46	Spacer Bushing	9642951.01	1	94	Hex Socket Head Bolt M6 × 10	*	2
47	Hex Socket Head Bolt M6 × 25	*	2	95	Clamp Screw	9645958.01	1
48	Adjust Handle	9642952.01	1	96	Washer M10	*	1

(Δ) Not shown.

(N/A) Not available as repair part.

(\*) Standard hardware item, available locally.

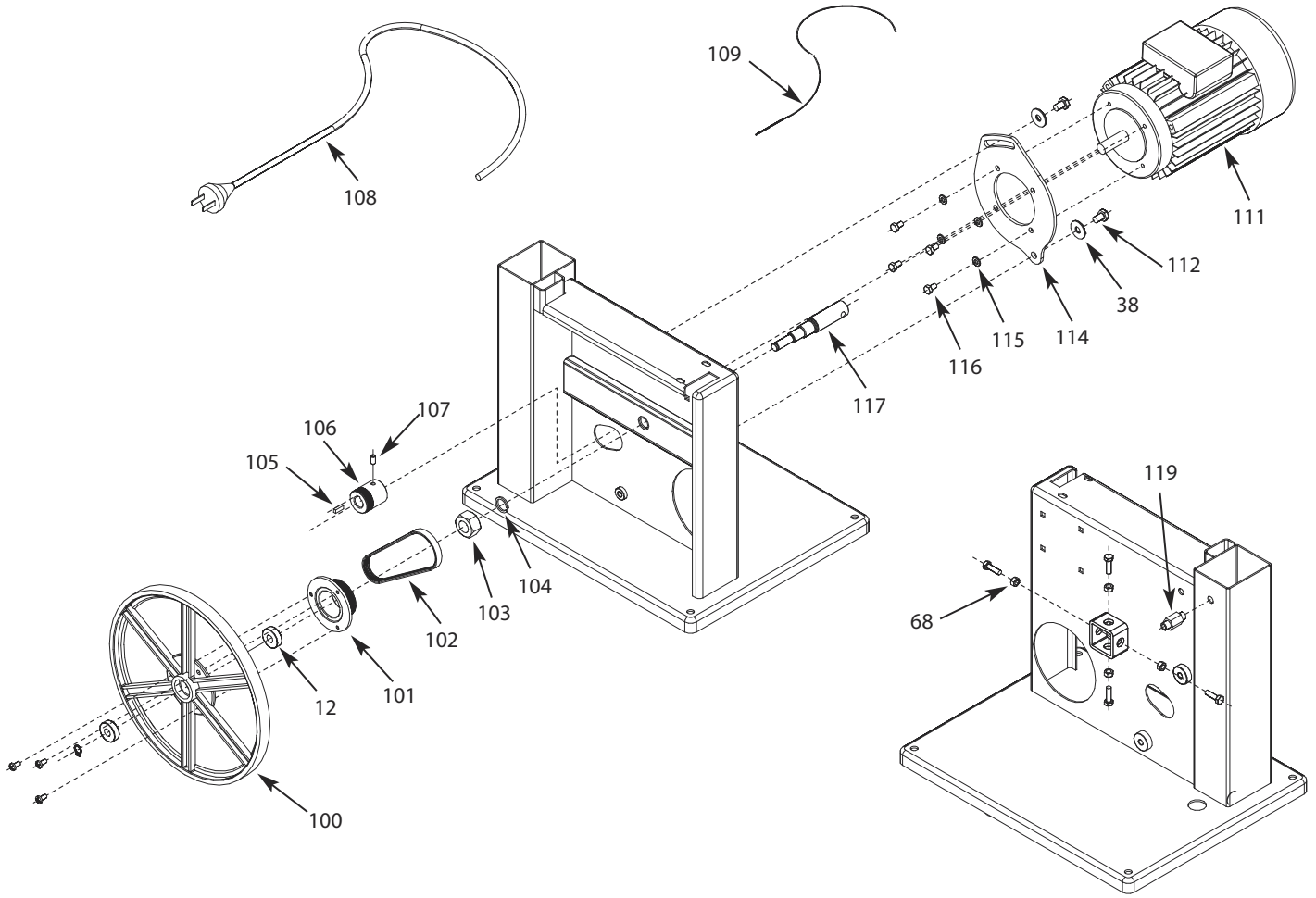

Figure 23 - Replacement parts illustration for 10" Bench Top Band Saw (continued).

**REPLACEMENT PARTS LIST FOR 10" BENCH TOP BAND SAW (CONTINUED)**

<b>Ref. No.</b>	<b>Description</b>	<b>Part Number</b>	<b>Qty.</b>
99	Pan Head Screw M5 × 10	*	3
100	Lower Wheel	9642989.01	1
101	Pulley	9642990.01	1
102	V-Ribbed Belt	9642991.01	1
103	Hex Nut M14 × 1.5	*	1
104	Spring Washer M14	*	1
105	Key M5 × 25	*	1
106	Motor Pulley	9342992.01	1
107	Hex Socket Set Screw M6 × 8	*	1
108	Power Cord	9642993.01	1
109	Motor Cord	9642994.01	1
111	Motor	9642996.01	1
112	Hex Head Bolt M8 × 16	*	2
114	Motor Mount Plate	9642997.01	1
115	Washer M6	*	4
116	Hex Head Bolt M6 × 16 Bearing	*	4
117	Drive Shaft	9642998.01	1
119	Relief Strain	9642999.01	1

(Δ) Not shown.

(N/A) Not available as repair part.

(\*) Standard hardware item, available locally.

## TROUBLESHOOTING

SYMPTOM	POSSIBLE CAUSE(S)	CORRECTIVE ACTION
The machine does not work when switched on.	<ol style="list-style-type: none"> <li>1. No power supply.</li> <li>2. Defective switch.</li> <li>3. Defective motor.</li> </ol>	<ol style="list-style-type: none"> <li>1. Check the cable for breakage.</li> <li>2. Replace the lock switch.</li> <li>3. Replace the motor.</li> </ol>
The saw blade does not move with the motor running.	<ol style="list-style-type: none"> <li>1. The blade tension knob has not been tightened.</li> <li>2. The blade has come off one of the wheels.</li> <li>3. The saw blade has broken.</li> <li>4. The drive belt has snapped.</li> </ol>	<ol style="list-style-type: none"> <li>1. Switch off the motor, tighten the blade tension knob.</li> <li>2. Open the doors and check</li> <li>3. Replace the blade.</li> <li>4. Replace the belt.</li> </ol>
The saw blade does not cut in a straight line.	<ol style="list-style-type: none"> <li>1. Rip fence for cutting not used.</li> <li>2. Feed rate too fast.</li> <li>3. The blade teeth are dull or damaged.</li> <li>4. Blade guides not suitably adjusted.</li> </ol>	<ol style="list-style-type: none"> <li>1. Use a rip fence.</li> <li>2. Put light pressure on the workpiece. Make sure the saw blade does not bend.</li> <li>3. Try a new saw blade.</li> <li>4. Adjust the blade guides (see OPERATION instructions).</li> </ol>
The saw blade does not cut, or cuts very slowly.	<ol style="list-style-type: none"> <li>1. The teeth are dull, caused by cutting hard material or long use.</li> <li>2. The saw blade was fitted the wrong way on the band saw.</li> </ol>	<ol style="list-style-type: none"> <li>1. Replace the saw blade, use a 6 T.P.I. saw blade for wood and soft material. Use a 14 T.P.I. saw blade for harder materials. A 14 T.P.I. saw blade always cuts slower due to the finer teeth and the slower cutting performance.</li> <li>2. Fit the saw blade correctly.</li> </ol>
Sawdust builds up inside the machine.	This is normal	Clean the machine regularly. Open the doors and remove the sawdust with a vacuum cleaner.
Sawdust inside the motor housing.	This is normal	Clean the ventilating slots of the motor with a vacuum cleaner. From time to time remove the sawdust to prevent it from being drawn into the housing.
The machine does not cut at 45 or 90 degrees.	<ol style="list-style-type: none"> <li>1. The table is not at right angles to the blade.</li> <li>2. The saw blade is dull or too much pressure was put on the workpiece.</li> </ol>	<ol style="list-style-type: none"> <li>1. Adjust the table.</li> <li>2. Replace the saw blade or put less pressure on the workpiece.</li> </ol>
The saw blade cannot be properly positioned on the wheels.	<ol style="list-style-type: none"> <li>1. The wheels are not in alignment or defective bearing.</li> <li>2. The blade tracking knob hasn't been properly adjusted.</li> <li>3. Inferior saw blade.</li> </ol>	<ol style="list-style-type: none"> <li>1. Replace bearing.</li> <li>2. Adjust the blade tracking knob (See OPERATION instructions).</li> <li>3. Replace the saw blade.</li> </ol>



## PALMGREN WARRANTY

C.H. Hanson / Palmgren warrants their products to be free of defects in material or workmanship. This warranty does not cover defects due directly or indirectly to misuse, abuse, normal wear and tear, failure to properly maintain the product, heated, ground or otherwise altered, or used for a purpose other than that for which it was intended.

The warranty does not cover expendable and/or wear part (i.e. v-belts, screws, abrasives, jaws), damage to tools arising from alteration, abuse or use other than their intended purpose, packing and freight. The duration of this warranty is expressly limited to the terms noted below beginning from the date of delivery to the original user.

**The Palmgren branded items carry the following warranties on parts:**

**All vises, clamps, positioning tables, tombstones, jack screws and vise accessories - LIFETIME.**

**All bench grinders, drill presses, tapping machines, band saws, lathes, milling machines, arbor presses, abrasive finishing machines and work stands - 3 YEARS.**

The obligation of C.H. Hanson / Palmgren is limited solely to the repair or replacement, at our option, at its factory or authorized repair agent of any part that should prove inoperable. Purchaser must lubricate and maintain the product under normal operating conditions at all times. Prior to operation become familiar with product and the included materials, i.e. warnings, cautions and manuals.

**Failure to follow these instructions will void the warranty.**

This warranty is the purchaser's exclusive remedy against C.H. Hanson for any inoperable parts in its product. Under no circumstances is C.H. Hanson liable for any direct, indirect, incidental, special or consequential damages including loss of profits in any way related to the use or inability to use our products. This warranty gives you specific legal rights which may vary from state to state.

**PALMGREN®**

**Palmgren - a C.H. Hanson Company**  
**2000 N. Aurora Rd., Naperville, IL 60563 U.S.A.**  
**or call 1-800-827-3398**