



PALMGREN®

12" DUAL SPEED BUFFER WITH GUARDS



Read carefully and follow all safety rules and operating instructions before first use of this product.



UNPACKING

Carton should be handled with care to avoid damage from dropping, bumping, etc. Store and unpack carton with correct side up. If any damage or loss has occurred, claim must be filed with carrier immediately. Check for completeness. Immediately report missing parts to dealer.

CONTENTS:

- Buffer
- Hex Nuts (2)
- Wheel Flanges (4)
- Spacers (2)
- Left and right guards with frame and matching hardware set (1)

UNPACK:

- Open carton and carefully remove Buffer components from packing material. Do not discard packing materials until after unit has been inspected for damage and completeness. Locate loose parts and set aside.

INSPECT:

- After unpacking the unit, carefully inspect for any damage that may have occurred during transit. Check for loose, missing or damaged parts. Shipping damage claims must be filed with the carrier.
- All tools should be visually inspected before use, in addition to regular periodic maintenance inspections.
- Be sure that the voltage labeled on the unit matches your power supply.

SAFETY RULES

WARNING: For your own safety, read all of the instructions and precautions before operating tool.

PROPOSITION 65 WARNING: Some dust created by using power tools contain chemicals known to the state of California to cause cancer, birth defects or other reproductive harm.

Some examples of these chemicals are:

- Lead from lead-based paints.
- Crystalline silica from bricks and cement and other masonry products.
- Arsenic and chromium from chemically-treated lumber.

Your risk from these exposures varies, depending on how often you do this type of work. To reduce your exposure to these chemicals: work in a well ventilated area and work with approved safety equipment. Always wear **OSHA/NIOSH** approved, properly fitting face mask or respirator when using such tools.

WARNING: Always follow proper operating procedures as defined in this manual even if you are familiar with the use of this or similar tools. Remember that being careless for even a fraction of a second can result in severe personal injury.

BE PREPARED FOR JOB

- Wear proper apparel. Do not wear loose clothing, gloves, neckties, rings, bracelets or other jewelry which may get caught in moving parts of machine.
- Wear protective hair covering to contain long hair.
- Wear safety shoes with non-slip soles.
- Wear safety glasses complying with United States ANSI Z87.1. Everyday glasses have only impact resistant lenses. They are **NOT**

safety glasses.

- Wear face mask or dust mask if operation is dusty.
- Be alert and think clearly. Never operate power tools when tired, intoxicated or when taking medications that cause drowsiness.

PREPARE WORK AREA FOR JOB

- Keep work area clean. Cluttered work areas invite accidents.
- Do not use power tools in dangerous environments. Do not use power tools in damp or wet locations. Do not expose power tools to rain.
- Work area should be properly lighted.
- Proper electrical plug should be plugged directly into properly grounded, three-prong receptacle.
- Extension cords should have a grounding prong and the three wires of the extension cord should be of the correct gauge.
- Keep visitors at a safe distance from work area.
- Keep children out of workplace. Make workshop childproof. Use padlocks, master switches or remove switch keys to prevent any unintentional use of power tools.

TOOL SHOULD BE MAINTAINED

- Always unplug tool prior to inspection.
- Consult manual for specific maintaining and adjusting procedures.
- Keep tool lubricated and clean for safest operation.
- Remove adjusting tools. Form habit of checking to see that adjusting tools are removed before switching machine on.
- Keep all parts in working order. Check to determine that the guard or other parts will operate properly and perform their intended function.
- Check for damaged parts. Check for alignment of moving parts, binding, breakage, mounting and any other condition that may affect a tool's operation.
- A guard or other part that is damaged should be properly repaired or replaced. Do not perform makeshift repairs. (Use parts list provided to order repair parts.)

KNOW HOW TO USE TOOL

- Use right tool for job. Do not force tool or attachment to do a job for which it was not designed.
- Disconnect tool from power when changing accessories such as grinding wheels, buffing wheels and the like.
- Avoid accidental start-up. Make sure that the switch is in the off position before plugging in.
- Do not force tool. It will work most efficiently at the rate for which it was designed.
- Keep hands away from moving parts and grinding surfaces.
- Never leave a tool running unattended. Turn the power off and do not leave tool until it comes to a complete stop.
- Do not overreach. Keep proper footing and balance.
- Never stand on tool. Serious injury could occur if tool is tipped over.
- Know your tool. Learn the tool's operation, application and specific limitations.
- Use recommended accessories. Understand and obey all safety instructions supplied with accessories. The use of improper accessories may cause risk of injury to persons.
- Do not over tighten wheel nut. Use only flanges supplied with the buffer.
- Handle the workpiece correctly.

CAUTION: Think safety! Safety is a combination of operator common sense and alertness at all times when tool is being used.

SPECIFICATIONS

Model number	9682105
Description	12" Dual Speed Buffer with Guards
Dimensions	38" x 15" x 16"
Stand Height	28"
Dust Port Outer Diameter	4"
Max Opening Width	7"
Distance Between Guards	22" - 24"
Horsepower (High Speed/Low Speed)	3 HP/1.5 HP
Voltage	230V
Amps (High Speed/Low Speed)	8.0 A/9.0 A
Hertz	60
Phase	3
RPM (High Speed/Low Speed)	3450/1720
Wheel Diameter	12"
Arbor	1-1/4"
Pole	2/4

ASSEMBLY

ASSEMBLING THE GUARD

1. Remove the pieces of the guard from the packaging.
2. Attach the two smaller L-brackets to the larger L-frame using M8x20 screws and washers, with the matching nut on the other side. Three sets of hardware items for each smaller L-bracket as shown in figures 1 and 2.



Figures 1 and 2 – Front and back of L-frame with L-brackets.

3. Attach Dust shroud to the smaller L-brackets using three M8x15 wing screw. Do this for both left and right guards.

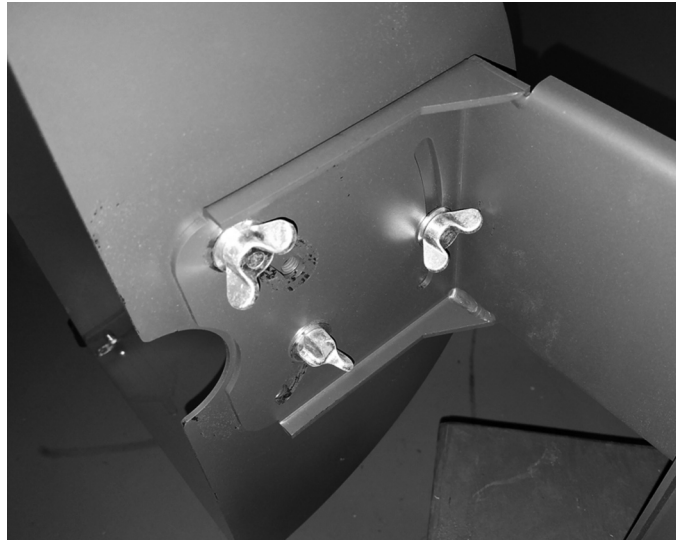

Figure 3 – Guard attached to L-bracket.

4. Attach the outer dust shroud cover to the dust shrouds using the provided black knobs. Three knobs for each side.

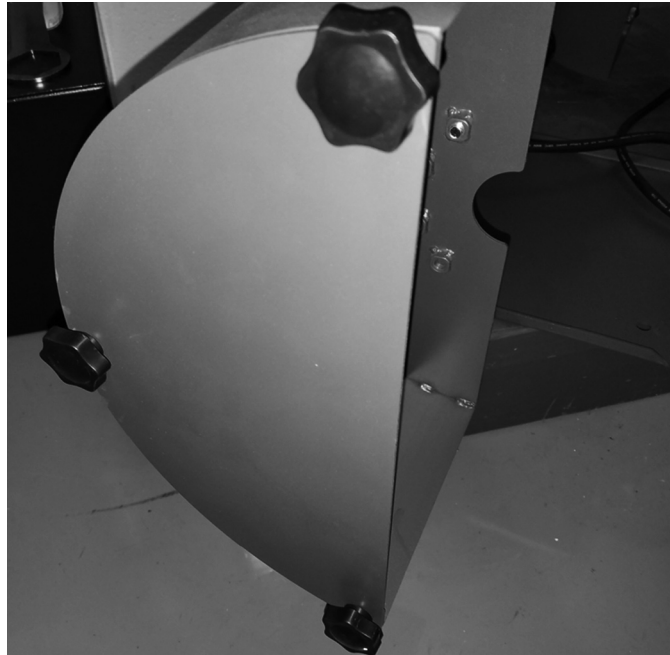

Figure 4 – Guard cover plate.



OPERATION

WARNING: Always wear safety glasses complying with United States ANSI 287.1 before commencing power tool operation.

- To power on, turn the red knob either left for low speed, or right for high speed.



Figure 5 – 3-Position switch.

- Speeds can be changed while the unit is running, rotation direction cannot be changed.
- Wheel rotates clockwise, when viewing from the end of the left side of the machine.
- Keep a steady, moderate pressure on the work and keep it moving at an even pace for smooth buffing.
- Pressing too hard overheats the motor and prematurely wears down the buffing wheels.
- The buffing wheel should rotate into object being buffed.



Figure 6 – Wheel rotation.

MAINTENANCE

- Replacement wheels must have a minimum rated speed of 3450 RPM.
- Maximum wheel diameter is 12”.
- Disconnect unit from power source before replacing buffing wheels or before performing any maintenance work.
- The threads on the right side of the buffer (facing unit) are right hand; threads on the left side are left hand. Hold the wheels firmly to loosen the hex nut
- Make sure hex nuts are tight and snug against the outer wheel flange prior to restarting buffer.





TROUBLESHOOTING

SYMPTOM	POSSIBLE CAUSE(S)	CORRECTIVE ACTION
Buffer won't start	1. Blown line fuse or tripped circuit breaker	1. If fuse is blown, replace with fuse of proper size. If breaker tripped, reset it
	2. Low line voltage	2. Check power supply for voltage and correct as needed
	3. Defective switch	3. Replace switch
Excessive vibration	1. Improper mounting of buffer	1. Remount buffer
	2. Buffing wheels not balanced.	2. Remount wheels, but rotate one wheel 90° with respect to its previous position. Other wheel should remaining its original position
Motor overheating	1. Excessive pressure required to buff workpiece	1. Worn wheel; replace
	2. Buffing on side of wheel	2. Perform buffing only on face of wheel
	3. Motor not turning freely (without power)	3. Clean around wheels and shaft and/or replace bearings
Fuses are being blown or circuit breakers are being tripped	1. Overloading due to binding	1. Clean around wheels and shaft and/or replace bearings
	2. Defective plug	2. Replace plug
	3. Defective cord	3. Replace cord
	4. Defective switch	4. Replace switch
	5. Faulty internal wiring	5. Contact authorized Palmgren Service Center



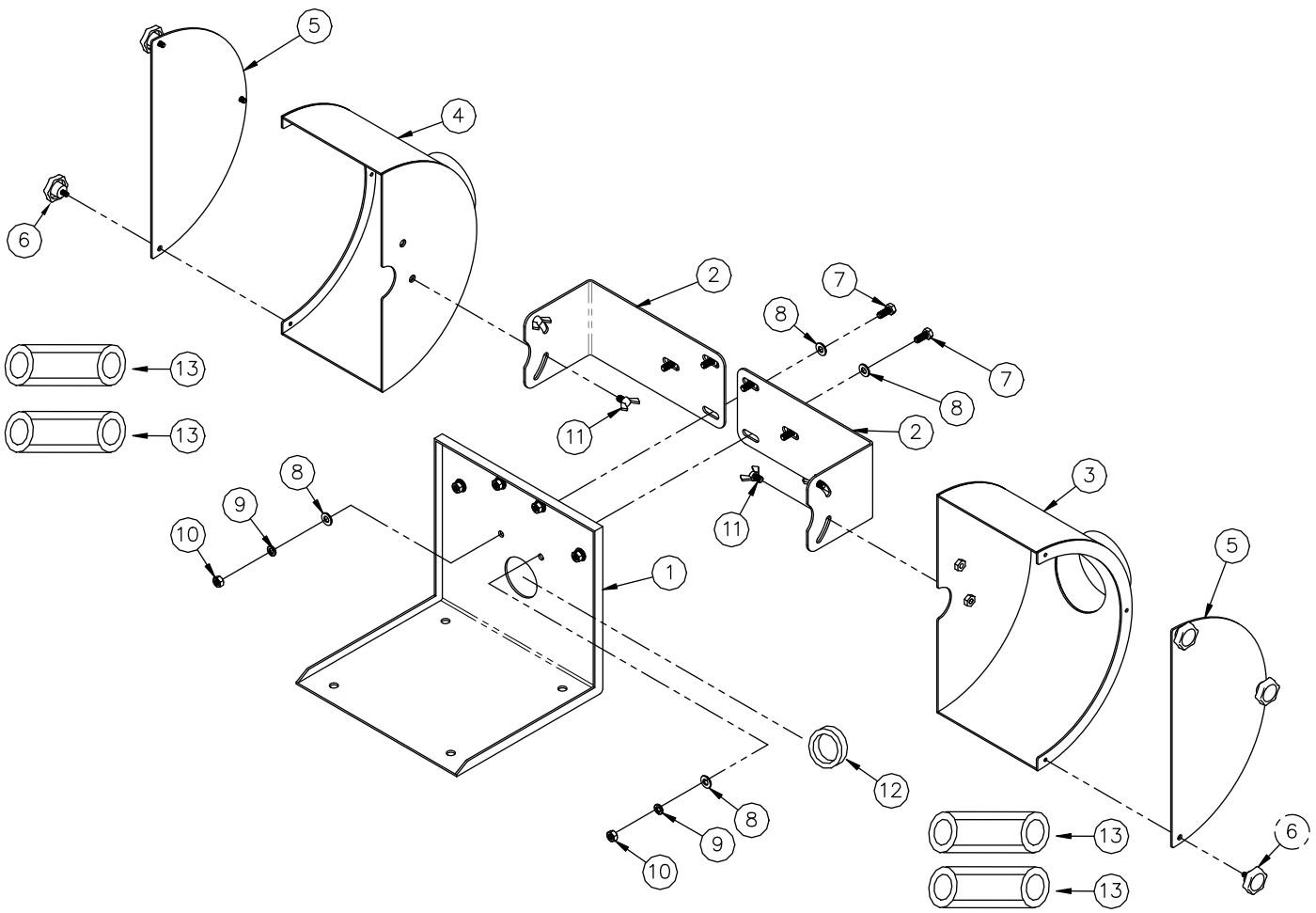

Figure 7 – Replacement parts illustration for Buffer Wheel Dust Shroud.

**REPLACEMENT PARTS LIST FOR BUFFER WHEEL DUST SHROUD**

Ref. No.	Description	Part Number	Qty.
1	Main L-frame	964748301	1
2	Extension bracket (L-bracket)	964748401	2
3	Dust shroud, right	964748501	1
4	Dust shroud, left	964748601	1
5	Dust shroud cover	964748701	2
6	knob 1/4 x 3/8	964748801	6
7	Hex head screw M8 x 20 x p1.25	*	6
8	Flat washer M8	*	12
9	Spring washer M8	*	6
10	Hex nut M8	*	6
11	Wing screw M8 x 15	*	4
12	Rubber grommet	964896401	1
13	Spacer 1.25x1"	964896501	4

(Δ) Not shown.

(N/A) Not available as repair part.

(*) Standard hardware item, available locally.



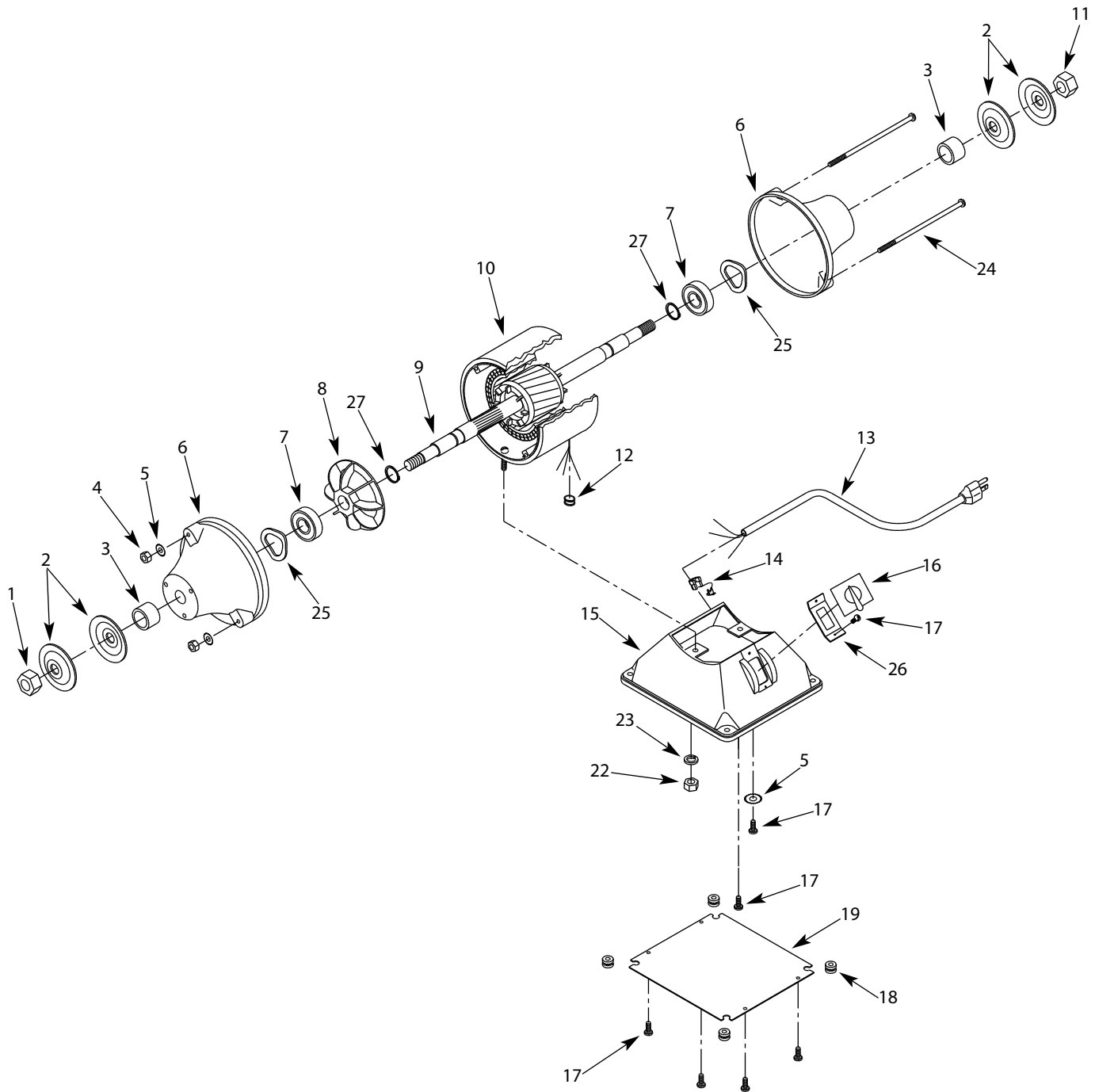

Figure 8 – Replacement Parts Illustration for 12" Dual Speed Buffer.

REPLACEMENT PARTS LIST FOR 12" DUAL SPEED BUFFER

Ref. No.	Description	Part Number	Qty.
1	Hex nut (LH thread)	964848701	1
2	wheel flange	964852101	4
3	Spacer	964848601	2
4	Hex nut	*	4
5	Serrated washer	*	3
6	Endshield	N/A	2
7	Bearing	N/A	2
8	Motor fan	N/A	2
9	Armature	N/A	1
10	Stator with housing	N/A	1
11	Hex nut (RH thread)	964848801	1
12	Grommet	N/A	1
13	Line cord	964852201	1
14	Strain relief grommet	964848901	1
15	Base	N/A	1
16	3 position Switch	See item 21 - switch assembly	1
17	Pan head screw	*	8
18	Bumper	964852301	4
19	Base grate	964852401	1
21	Switch assembly	964848501	1
22	Hex nut	*	2
23	Lock washer	*	2
24	Flange screw	N/A	2
25	Wavy washer	N/A	2
26	Switch plate	See item 21 - switch assembly	1
27	Retaining ring	N/A	2

(Δ) Not shown.

(N/A) Not available as repair part.

(*) Standard hardware item, available locally.

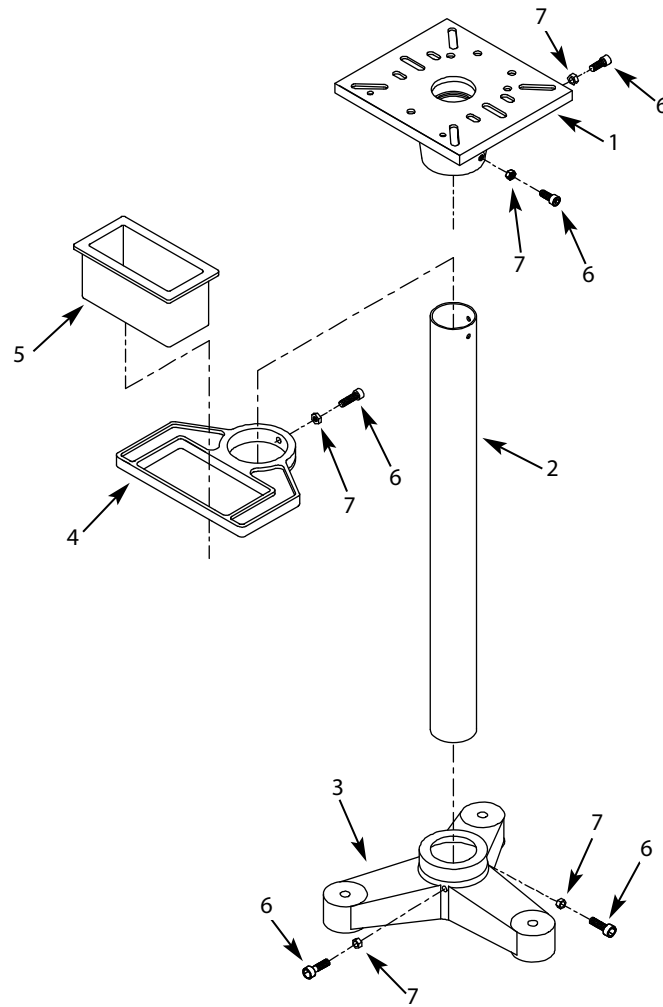

Figure 9 – Repair Parts Illustration for Stand



**REPLACEMENT PARTS LIST FOR STAND**

Ref. No.	Description	Part Number	Qty.
1	Top	9604889.01	1
2	Column	9624899.00	1
3	Base	9624898.00	1
4	Water pot holder	9624954.00	1
5	Water pot	9624955.00	1
6	3/8-16 × 1¼" Socket head bolt	*	5
7	3/8-16 Hex nut	*	5
Δ	8-1.25 × 45mm Hex head bolt	*	4
Δ	8mm Flat washer	*	8
Δ	8mm Lock washer	*	4
Δ	8-1.25mm Hex nut	*	4

(Δ) Not shown.

(N/A) Not available as repair part.

(*) Standard hardware item, available locally.



PALMGREN WARRANTY

C.H. Hanson / Palmgren warrants their products to be free of defects in material or workmanship. This warranty does not cover defects due directly or indirectly to misuse, abuse, normal wear and tear, failure to properly maintain the product, heated, ground or otherwise altered, or used for a purpose other than that for which it was intended.

The warranty does not cover expendable and/or wear part (i.e. v-belts, screws, abrasives, jaws), damage to tools arising from alteration, abuse or use other than their intended purpose, packing and freight. The duration of this warranty is expressly limited to the terms noted below beginning from the date of delivery to the original user.

The Palmgren branded items carry the following warranties on parts:

All arbor presses, vises, clamps, positioning tables, tombstones, jack screws and vise accessories - LIFETIME.

All bench grinders, drill presses, tapping machines, band saws, lathes, milling machines, abrasive finishing machines and work stands - 3 YEARS.

The obligation of C.H. Hanson / Palmgren is limited solely to the repair or replacement, at our option, at its factory or authorized repair agent of any part that should prove inoperable. Purchaser must lubricate and maintain the product under normal operating conditions at all times. Prior to operation become familiar with product and the included materials, i.e. warnings, cautions and manuals.

Failure to follow these instructions will void the warranty.

This warranty is the purchaser's exclusive remedy against C.H. Hanson for any inoperable parts in its product. Under no circumstances is C.H. Hanson liable for any direct, indirect, incidental, special or consequential damages including loss of profits in any way related to the use or inability to use our products. This warranty gives you specific legal rights which may vary from state to state.

PALMGREN®

Palmgren - a C.H. Hanson Company
2000 N. Aurora Rd., Naperville, IL 60563 U.S.A.
or call 1-800-827-3398