

# PALMGREN<sup>®</sup>

## 10" BUFFER GUARD



***Read carefully and follow all safety rules and operating instructions before first use of this product.***

# SPECIFICATIONS

Overall Dimensions ..... 11" x 5.83" x 8.5"  
Dust Chute Diameter ..... 1.54"  
Mounting Dimensions ..... See Drawing

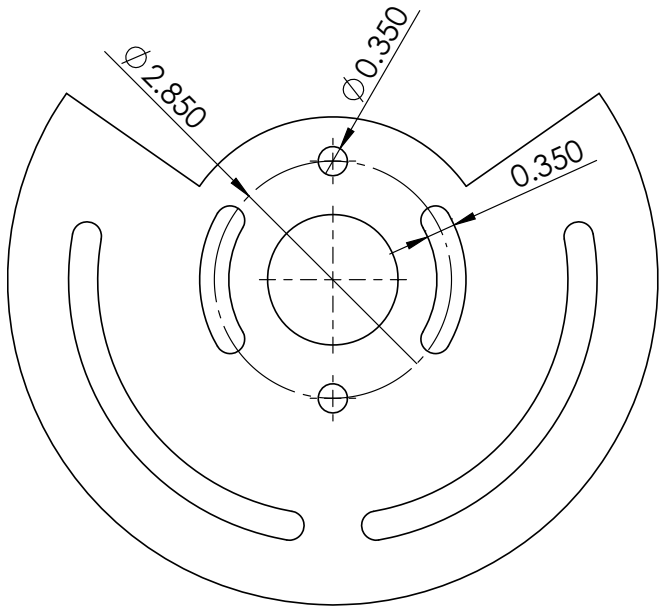

Figure 1 – Mounting bracket.

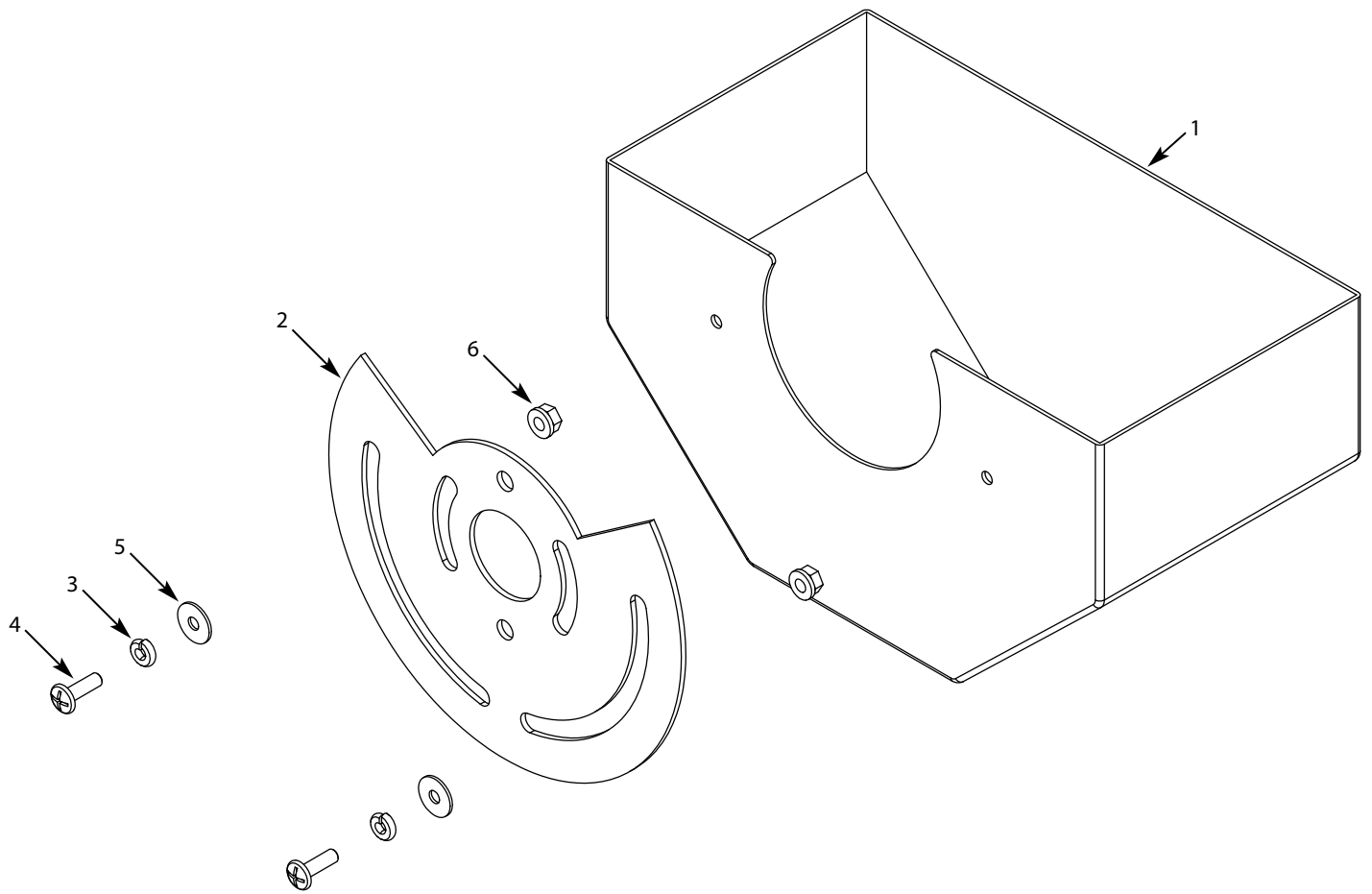

Figure 2 – Repair parts illustration for 9682099 buffer guard.

**REPLACEMENT PARTS LIST FOR 9682099 BUFFER GUARD**

Ref. No.	Description	Part Number	Qty.
1	Dust guard	964852801	1
2	Mounting bracket	964852901	1
3	1/4" lock washer	*	2
4	1/4" x .75" machine screw	*	2
5	1/4" washer	*	2
6	1/4" flange nut	*	2

(Δ) Not shown.

(N/A) Not available as repair part.

(\*) Standard hardware item, available locally.

## PALMGREN WARRANTY

C.H. Hanson / Palmgren warrants their products to be free of defects in material or workmanship. This warranty does not cover defects due directly or indirectly to misuse, abuse, normal wear and tear, failure to properly maintain the product, heated, ground or otherwise altered, or used for a purpose other than that for which it was intended.

The warranty does not cover expendable and/or wear part (i.e. v-belts, screws, abrasives, jaws), damage to tools arising from alteration, abuse or use other than their intended purpose, packing and freight. The duration of this warranty is expressly limited to the terms noted below beginning from the date of delivery to the original user.

**The Palmgren branded items carry the following warranties on parts:**

**All arbor presses, vises, clamps, positioning tables, tombstones, jack screws and vise accessories - LIFETIME.**

**All bench grinders, drill presses, tapping machines, band saws, lathes, milling machines, abrasive finishing machines and work stands - 3 YEARS.**

The obligation of C.H. Hanson / Palmgren is limited solely to the repair or replacement, at our option, at its factory or authorized repair agent of any part that should prove inoperable. Purchaser must lubricate and maintain the product under normal operating conditions at all times. Prior to operation become familiar with product and the included materials, i.e. warnings, cautions and manuals.

**Failure to follow these instructions will void the warranty.**

This warranty is the purchaser's exclusive remedy against C.H. Hanson for any inoperable parts in its product. Under no circumstances is C.H. Hanson liable for any direct, indirect, incidental, special or consequential damages including loss of profits in any way related to the use or inability to use our products. This warranty gives you specific legal rights which may vary from state to state.

# PALMGREN®

**Palmgren - a C.H. Hanson Company**  
**2000 N. Aurora Rd., Naperville, IL 60563 U.S.A.**  
**or call 1-800-827-3398**