

PALMGREN[®]

6" BENCH GRINDER WITH LIGHT



Read carefully and follow all safety rules and operating instructions before first use of this product.

GETTING STARTED

STRUCTURAL REQUIREMENTS

Make sure all supporting structures and load attaching devices are strong enough to hold your intended loads. If in doubt, consult a qualified structural engineer.

ELECTRICAL REQUIREMENTS

WARNING: To avoid electrical shock to yourself and damage to the Bench Grinder, use proper circuit protection.

The Bench Grinder is factory wired for 120V, 60 Hz, operation. Connect to a 120V, 15 amp branch circuit and use a 15 amp time delay fuse or circuit breaker. The electrical circuit cannot have any wire size less than #14. To avoid shock or fire, replace power cord immediately if it is damaged in any way.

TOOLS NEEDED:

Standard mechanic's hand tool set.

UNPACKING

Carton should be handled with care to avoid damage from dropping, bumping, etc. Store and unpack carton with correct side up. After unpacking Bench Grinder, inspect carefully for any damage that may have occurred during transit. Check for loose, missing or damaged parts. If any damage or loss has occurred, claim must be filed with carrier immediately. Check for completeness. Immediately report missing parts to dealer.

Do not discard packing materials until after machine has been inspected for damage and completeness. Locate loose parts and set aside.

WARNING: If any parts are missing, do not attempt to plug in the power cord and turn "ON" the Bench Grinder. The Bench Grinder can only be turned "ON" after all the parts have been obtained and installed correctly.

This Bench Grinder will require a minimal amount of assembly.

Remove any protective materials and coatings from all of the parts and the bench grinder. The protective coatings can be removed by spraying WD-40 on them and wiping it off with a soft cloth. This may need to be redone several times before all of the protective coatings are removed completely.

CAUTION: DO NOT use acetone, gasoline or lacquer thinner to remove any protective coatings.

CONTENTS:

Refer to Figure 1

- Grinder (not shown) (1)
- B. Eyeshield assembly (2)
- C. Carriage head screw M6 x 12mm (2)
- D. Hex head screw, M6 x 20 (2)
- E. Flat washer M6 (4)
- F. Eyeshield knob (2)
- G. Hex head screw M8 x 12mm (4)
- H. Flat washer M8 (4)
- I. Spark arrestor, left
- J. Spark arrestor, right
- K. Tool rest support, right
- L. Tool rest support, left
- M. Tool rest, right

- N. Tool rest, left
- O. Hex head screw, M5 x 10 (4)
- P. Lock washer M5 (4)
- Q. Flat washer M5 (4)
- R. Lock Washer M6 (2)
- Operating Instructions and Parts Manual (Not Shown) (1)

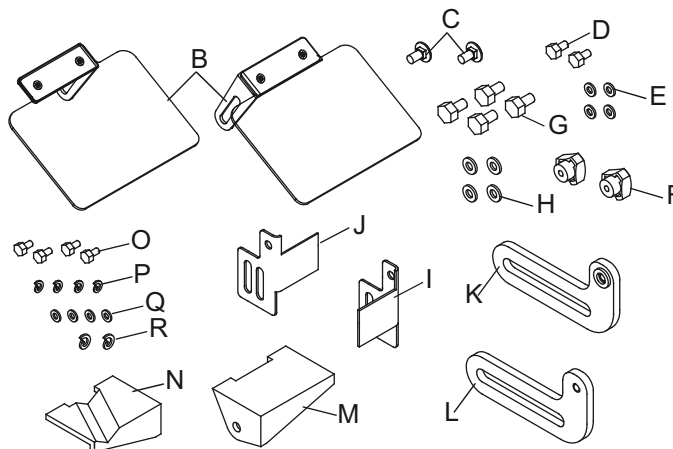

Figure 1 - Contents

INSPECT:

- All tools should be visually inspected before use, in addition to regular periodic maintenance inspections.
- Be sure that the voltage labeled on the unit matches your power supply.

SAFETY RULES

GENERAL SAFETY INSTRUCTIONS

Operating a Bench Grinder can be dangerous if safety and common sense are ignored. The operator must be familiar with the operation of the tool. Read this manual to understand this Bench Grinder. DO NOT operate this Bench Grinder if you do not fully understand the limitations of this tool. DO NOT modify this Bench Grinder in any way.

WARNING: For your own safety, read all of the instructions and precautions before operating tool.

PROPOSITION 65 WARNING: Some dust created by using power tools contain chemicals known to the state of California to cause cancer, birth defects or other reproductive harm.

Some examples of these chemicals are:

- Lead from lead-based paints.
- Crystalline silica from bricks and cement and other masonry products.
- Arsenic and chromium from chemically-treated lumber.

Your risk from these exposures varies, depending on how often you do this type of work. To reduce your exposure to these chemicals: work in a well ventilated area and work with approved safety equipment. Always wear **OSHA/NIOSH** approved, properly fitting face mask or respirator when using such tools.

WARNING: Always follow proper operating procedures as defined in this manual even if you are familiar with the use of this or similar tools. Remember that being careless for even a fraction of a second can result in severe personal injury.

SAFETY RULES (CONTINUED)

- READ the entire Owner's Manual. LEARN how to use the tool for its intended applications.
- GROUND ALL TOOLS. If the tool is supplied with a 3-prong plug, it must be plugged into a 3-contact electrical receptacle. The 3rd prong is used to ground the tool and provide protection against accidental electric shock. DO NOT remove the 3rd prong. See Grounding Instructions on page 8 and 9.
- AVOID A DANGEROUS WORKING ENVIRONMENT. DO NOT use electrical tools in a damp environment or expose them to rain.
- DO NOT use electrical tools in the presence of flammable liquids or gasses.
- ALWAYS keep the work area clean, well lit, and organized. DO NOT work in an environment with floor surfaces that are slippery from debris, grease, and wax.
- KEEP VISITORS AND CHILDREN AWAY. DO NOT permit people to be in the immediate work area, especially when the electrical tool is operating.
- DO NOT FORCE THE TOOL to perform an operation for which it was not designed. It will do a safer and higher quality job by only performing operations for which the tool was intended.
- WEAR PROPER CLOTHING. DO NOT wear loose clothing, gloves, neckties, or jewelry. These items can get caught in the machine during operations and pull the operator into the moving parts. The user must wear a protective cover on their hair, if the hair is long, to prevent it from contacting any moving parts.
- CHILDPROOF THE WORKSHOP AREA by removing switch keys, unplugging tools from the electrical receptacles, and using padlocks.
- DO NOT use electrical tools in the presence of flammable liquids or gasses.
- ALWAYS UNPLUG THE TOOL FROM THE ELECTRICAL RECEPTACLE when making adjustments, changing parts or performing any maintenance.
- KEEP PROTECTIVE GUARDS IN PLACE AND IN WORKING ORDER.
- AVOID ACCIDENTAL STARTING. Make sure that the power switch is in the "OFF" position before plugging in the power cord to the electrical receptacle.
- REMOVE ALL MAINTENANCE TOOLS from the immediate area prior to turning "ON" the Bench Grinder.
- USE ONLY RECOMMENDED ACCESSORIES. Use of incorrect or improper accessories could cause serious injury to the operator and cause damage to the tool. If in doubt, check the instruction manual that comes with that particular accessory.
- NEVER LEAVE A RUNNING TOOL UNATTENDED. Turn the power switch to the "OFF" position. DO NOT leave the tool until it has come to a complete stop.
- DO NOT STAND ON A TOOL. Serious injury could result if the tool tips over or you accidentally contact the tool.
- DO NOT store anything above or near the tool where anyone might try to stand on the tool to reach it.
- MAINTAIN YOUR BALANCE. DO NOT extend yourself over the tool. Wear oil resistant rubber soled shoes. Keep floor clear of debris, grease, and wax.
- MAINTAIN TOOLS WITH CARE. Always keep tools clean and in good working order. Keep all blades and tool bits sharp.
- EACH AND EVERY TIME, CHECK FOR DAMAGED PARTS PRIOR TO USING THE TOOL. Carefully check all guards to see that they operate properly, are not damaged, and perform their intended functions. Check for alignment, binding or breaking of moving parts. A guard or other part that is damaged should be immediately repaired or replaced.
- CHILDPROOF THE WORKSHOP AREA by removing switch keys, unplugging tools from the electrical receptacles, and using padlocks.
- DO NOT OPERATE TOOL IF UNDER THE INFLUENCE OF DRUGS OR ALCOHOL.
- SECURE ALL WORK. Use clamps or jigs to secure the workpiece. This is safer than attempting to hold the workpiece with your hands.
- STAY ALERT, WATCH WHAT YOU ARE DOING, AND USE COMMON SENSE WHEN OPERATING A POWER TOOL. DO NOT USE A TOOL WHILE TIRED OR UNDER THE INFLUENCE OF DRUGS, ALCOHOL, OR MEDICATION. A moment of inattention while operating power tools may result in serious personal injury.
- ALWAYS WEAR A DUST MASK TO PREVENT INHALING DANGEROUS DUST OR AIRBORNE PARTICLES, including wood dust, crystalline silica dust and asbestos dust. Direct particles away from face and body. Always operate tool in well ventilated area and provide for proper dust removal. Use dust collection system wherever possible. Exposure to the dust may cause serious and permanent respiratory or other injury, including silicosis (a serious lung disease), cancer, and death. Avoid breathing the dust, and avoid prolonged contact with dust. Allowing dust to get into your mouth or eyes, or lay on your skin may promote absorption of harmful material. Always use properly fitting **NIOSH/OSHA** approved respiratory protection appropriate for the dust exposure, and wash exposed areas with soap and water.
- USE A PROPER EXTENSION CORD IN GOOD CONDITION. When using an extension cord, be sure to use one heavy enough to carry the current your product will draw. The table at right shows the correct size to use depending on cord length and nameplate amperage rating. If in doubt, use the next heavier gauge. The smaller the gauge number, the larger diameter of the extension cord. If in doubt of the proper size of an extension cord, use a shorter and thicker cord. An undersized cord will cause a drop in line voltage resulting in a loss of power and overheating. USE ONLY A 3-WIRE EXTENSION CORD THAT HAS A 3-PRONG GROUNDING PLUG AND A 3-POLE RECEPTACLE THAT ACCEPTS THE TOOL'S PLUG.
- USE A PROPER EXTENSION CORD IN GOOD CONDITION. When using an extension cord, be sure to use one heavy enough to carry the current your product will draw. The table at right shows the correct size to use depending on cord length and nameplate amperage rating. If in doubt, use the next heavier gauge. The smaller the gauge number, the larger diameter of the extension cord. If in doubt of the proper size of an extension cord, use a shorter and thicker cord. An undersized cord will cause a drop in line voltage resulting in a loss of power and overheating. USE ONLY A 3-WIRE EXTENSION CORD THAT HAS A 3-PRONG GROUNDING PLUG AND A 3-POLE RECEPTACLE THAT ACCEPTS THE TOOL'S PLUG.

SAFETY RULES (CONTINUED)**SPECIFIC SAFETY INSTRUCTIONS FOR BENCH GRINDERS**

The operation of any grinder can result in debris being thrown into your eyes, which can result in severe eye damage. **ALWAYS WEAR EYE PROTECTION.** Any power tool can throw debris during operations, which could cause severe and permanent eye damage. Everyday eyeglasses are **NOT** safety glasses. **ALWAYS** wear Safety Goggles (that comply with ANSI standard Z87.1) when operating power tools.

Basic precautions should always be followed when using your Bench Grinder. To reduce the risk of injury, electrical shock, or fire, comply with the safety rules listed below:

- ALWAYS USE THE EYE SHIELDS AND WHEEL GUARDS provided with the grinder.
- REPLACE A CRACKED OR DAMAGED GRINDING WHEEL IMMEDIATELY. A damaged wheel can discharge debris at a high velocity towards the operator. Carefully handle the grinding wheels since they are abrasive. Prior to replacing a grinding wheel, check it for cracks. **DO NOT** remove the blotter or label on both sides of the grinding wheel. Tighten the spindle nut just enough to hold the grinding wheel firmly to the Bench Grinder. Do not over-tighten the nut. Excessive clamping force can damage the grinding wheel. Only use the wheel flanges provided with the grinder. When selecting a replacement grinding wheel, verify that the grinding wheel has a higher R.P.M. rating than the maximum R.P.M. of the Bench Grinder.
- THE DIAMETER OF THE GRINDING WHEELS WILL DECREASE WITH USE. Adjust the tool rests and spark arrestors to maintain a distance of 1/16" from the wheel.
- DO NOT STAND IN FRONT OF THE BENCH GRINDER WHEN STARTING IT. Stand to one side of the Bench Grinder and turn it "ON". Wait at the side for one minute until the grinder comes up to full speed. There is always a possibility that debris from a damaged grinding wheel may be discharged towards the operator.
- THE BENCH GRINDER WILL PRODUCE SPARKS AND DEBRIS DURING GRINDING OPERATIONS. Be sure that there are not any flammable materials in the vicinity. Frequently clean grinding dust from the back of the Bench Grinder.
- NEVER FORCE THE WORKPIECE AGAINST A GRINDING WHEEL, especially if the wheel is cold. Apply the workpiece slowly, allowing the grinding wheel an opportunity to warm up. This will minimize the chance of wheel breakage. **DO NOT** grind using the sides of the grinding wheels. **DO NOT** apply coolant directly to the grinding wheel.
- KEEP ALL WHEEL GUARDS IN PLACE. **DO NOT** USE THE BENCH GRINDER WITH THE WHEEL GUARDS REMOVED.
- KEEP THE TOOL RESTS FIRMLY TIGHTENED.
- ALWAYS USE THE SUPPLIED WHEEL DRESSER TO RESURFACE THE FACE OF THE GRINDING WHEEL.
- REMOVE ADJUSTING KEYS AND WRENCHES. Form habit of checking to see that keys and adjusting wrenches are removed from tool before turning it on.
- DIRECTION OF FEED. Feed work into a blade or cutter against the direction of rotation of the blade or cutter only.
- USE RIGHT TOOL. Don't force tool or attachment to do a job for which it was not designed.
- DO NOT overtighten wheel nut.
- ONLY use flanges furnished with the grinder.
- FREQUENTLY clean grinding dust from beneath grinder.

- **DO NOT FORCE THE TOOL** to perform an operation for which it was not designed. It will do a safer and higher quality job by only performing operations for which the tool was intended.
- **SAVE THESE INSTRUCTIONS.** Refer to them frequently and use them to instruct others.

SPECIFICATIONS**KNOW YOUR BENCH GRINDER**

Refer to Figure 2.

1. INNER WHEEL GUARD - Covers the grinding wheels and protects against accidental contact.
2. WHEEL COVER - Covers the grinding wheels and provides quick access for routine maintenance.
3. MOTOR HOUSING - Contains the electrical motor.
4. MOUNTING FEET - Helps to minimize the vibration of the grinder.
5. SPARK ARRESTOR - Prevents hot sparks and debris from contacting the operator.
6. EYESHIELD - Protective Lexan see-thru shields to prevent any loose debris from contacting the operator.
7. FLEXIBLE WORK LIGHT - Provides light to the operator during set up or grinding operations.
8. TOOL REST ADJUSTABLE SUPPORTS - Lets the operator position the tool rest closer to the wheel as the wheel decreases in diameter due to wear.
9. TOOL RESTS - Used to support the workpiece that is being ground. Adjustable to provide angled surfaces.
10. GRINDING WHEEL 36 GRIT - Used to remove heavy material from workpiece.
11. GRINDING WHEEL 60 GRIT - Used to remove light material from workpiece.
12. ON/OFF SWITCH - Used to turn ON and turn OFF the grinder.
13. GRINDING WHEEL IDENTIFICATION LABEL - Provides information on wheel size, grit and maximum RPM.
14. FLANGES - used to secure the grinding wheels to the grinder and distribute the load of the Lock Nuts.
15. ARBOR HEX NUT - Used to secure the grinding wheels to the grinder.

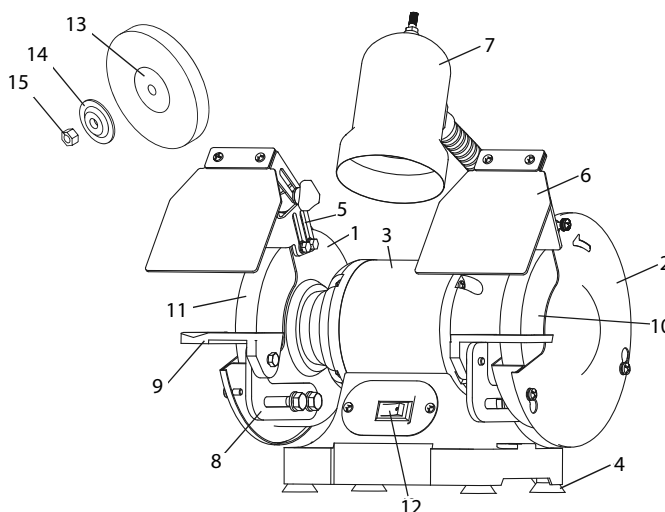

Figure 2 - Know Your Bench Grinder

SPECIFICATIONS (CONTINUED)

6" BENCH GRINDER WITH LIGHT SPECIFICATIONS

Motor	Continuous Duty 1/3 HP, 120V, 2.1A, 60Hz, 3450 RPM (no load speed)
Grinding Wheel Size6" x 3/4", 1/2" bore
Grinding Wheel Grit60, 36
Lamp 120V40 watt or less bulb type R20, medium base or equivalent (not included)
Tool Rests	Left and Right
Eye Shield Assemblies	Clear Lexan Left and Right
Spark Arrestors	Left and Right

ASSEMBLY

WARNING: DO NOT assemble the Bench Grinder until you are sure the tool is NOT plugged in. DO NOT assemble the Bench Grinder until you are sure the power switch is in the "OFF" position. DO NOT assemble the Bench Grinder until you are sure the grinding wheels are firmly tightened to the Bench Grinder.

TOOL RESTS

Refer to Figures 3 and 4.

The Bench Grinder is provided with two Tool Rest assemblies.

1. Assemble the Tool Rest Supports (A) to the inside surface of the Wheel Covers (B) with the flat washers (C) and hex head screws (D) as shown. See Figure 3.

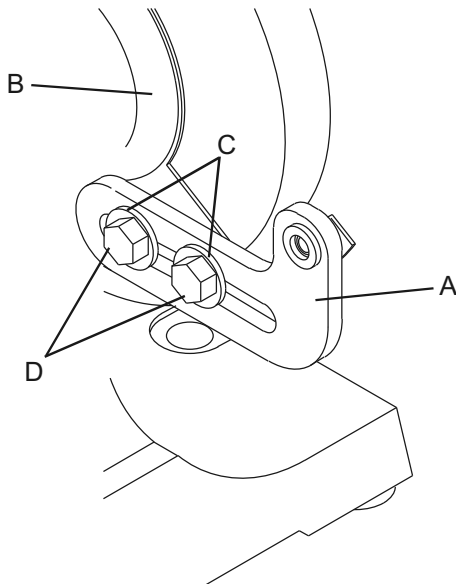

Figure 3 - Assemble Tool Rest Supports

2. Assemble the Tool Rests (E) to the Supports (F) with the flat washers (G) and hex head screws (H) as shown. See Figure 4.
3. Adjust each Tool Rest until its inside edge (I) is 1/16" from the grinding wheel. Firmly tighten the hex head screws holding the supports. See Figure 4.

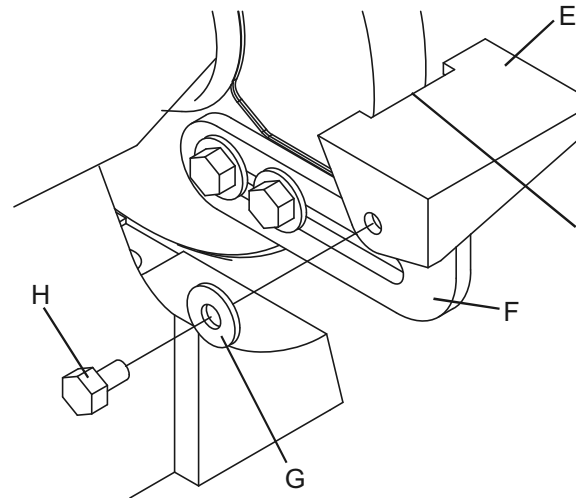

Figure 4 - Assemble Tool Rests to Supports

SPARK ARRESTORS

Refer to Figure 5

1. Assemble the Spark Arrestors (A) to the inside surface of the Wheel Covers (B) with the hex head screws with washers (C) as shown. See Figure 5.
2. Adjust each Spark Arrestor until the lower edge (E) is 1/16" from the grinding wheel. Firmly tighten the hex head screws. See Figure 5.

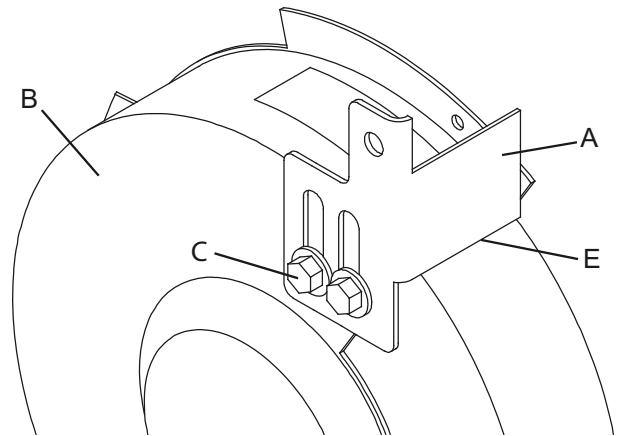

Figure 5 - Spark Arrestors

ASSEMBLY (CONTINUED)

EYESHIELDS

Refer to Figure 6

1. Assemble the eyeshield (C) to the Spark Arrestor (A) inserting carriage head screw (B) through Eyeshield and the Spark Arrestor as shown. See Figure 6.
2. Assemble the flat washer (D), lockwasher (F) and Lock Knob (E) to the carriage head screw and tighten until the Eyeshield remains in the desired position. See Figure 6.

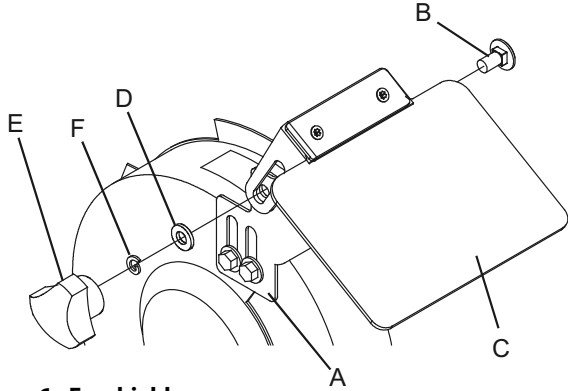

Figure 6 - Eyeshields

WORKLIGHT

Refer to Figure 7

The Bench Grinder is provided with a Flexible Work Light to assist in visibility of the workpiece.

The Bench Grinder is NOT provided with a light bulb for the Flexible Work Light.

WARNING: To reduce the risk of fire, use a 120 volt, 40 Watt or less Track Light Bulb, Type R20, medium base or equivalent (not included). DO NOT use a light bulb that extends past the end of the light housing.

The Flexible Work Light may be turned "ON" or "OFF" by using the rotary switch (B) on the top surface of the housing (A). The switch can be rotated in the clockwise direction only. See Figure 7.

NOTE: The Flexible Work Light can be turned "ON" or "OFF" even if the Bench Grinder is turned "OFF".

CAUTION: The Flexible Work Light housing will remain hot for a few minutes after turning it "OFF". Avoid contact with housing until it is cool.

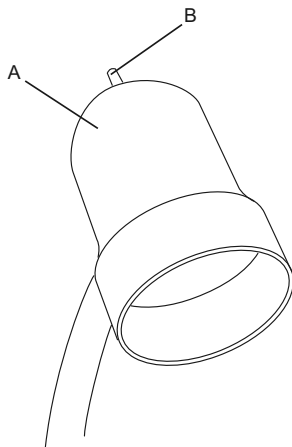

Figure 7 - Work light.

PERMANENT MOUNTING

Refer to Figure 8.

Use the mounting pads on the base of the grinder to firmly attach grinder to a solid work surface (hardware not included).

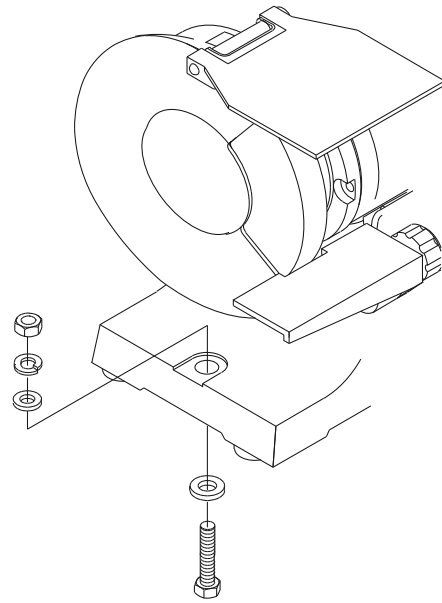

Figure 8 - Permanent Mounting

WARNING: To avoid serious injury, secure the Bench Grinder to a solid work surface. If the Bench Grinder is not securely mounted, it will have the ability to move or tip over during grinding operations and possibly cause the operator's fingers to contact the grinding wheels.

INSTALLATION

WARNING: If any parts are missing, do not attempt to plug in the power cord and turn "ON" the Bench Grinder. The Bench Grinder can only be turned "ON" after all the parts have been obtained and installed correctly.

EXTENSION CORDS

- The use of any extension cord will cause some drop in voltage and loss of power.
- Wires of the extension cord must be of sufficient size to carry the current and maintain adequate voltage.
- Running the unit on voltages which are not within $\pm 10\%$ of the specified voltage may cause overheating and motor burn-out.
- Use the table to determine the minimum wire size (A.W.G.) extension cord.
- Use only 3-wire extension cords having 3-prong grounding type plugs and 3-pole receptacles which accept the tool plug.
- If the extension cord is worn, cut or damaged in any way, replace it immediately.

Extension Cord Table						
		Volts	Total Length of Cord in Feet			
Ampere Rating		120	25	50	100	150
More Than	Not More Than	240	50	100	150	300
		Minimum Gage for Cord				
0	6		18	16	16	14
6	10		18	16	14	12
10	12		16	16	14	12
12	16		14	12	Not Recommended	

INSTALLATION (CONTINUED)

GROUNDING INSTRUCTIONS

Refer to Figures 9 and 10.

THIS TOOL MUST BE GROUNDED WHILE IN USE TO PROTECT THE OPERATOR FROM ELECTRIC SHOCK.

IN THE EVENT OF A MALFUNCTION OR BREAKDOWN, grounding provides the path of least resistance for electric current and reduces the risk of electric shock. This tool is equipped with an electric cord that has an equipment grounding conductor and a grounding plug. The plug **MUST** be plugged into a matching electrical receptacle that is properly installed and grounded in accordance with ALL local codes and ordinances.

DO NOT MODIFY THE PLUG PROVIDED. If it will not fit the electrical receptacle, have the proper electrical receptacle installed by a qualified electrician.

IMPROPER ELECTRICAL CONNECTION of the equipment grounding conductor can result in risk of electric shock. The conductor with the green insulation (with or without yellow stripes) is the equipment grounding conductor. **DO NOT** connect the equipment grounding conductor to a live terminal if repair or replacement of the electric cord or plug is necessary.

CHECK with a qualified electrician or service personnel if you do not completely understand the grounding instructions, or if you are not sure the tool is properly grounded.

USE ONLY A 3-WIRE EXTENSION CORD THAT HAS A 3-PRONG GROUNDING PLUG AND A 3-POLE RECEPTACLE THAT ACCEPTS THE TOOL'S PLUG.

REPLACE A DAMAGED OR WORN CORD IMMEDIATELY.

This tool is intended for use on a circuit that has an electrical receptacle as shown in Figure 9. Figure 9 shows a 3-wire electrical plug and electrical receptacle that has a grounding conductor.

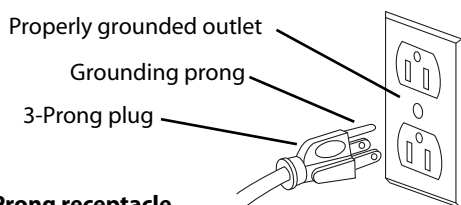

Figure 9 – 3-Prong receptacle

If a properly grounded electrical receptacle is not available, an adapter as shown in Figure 10 can be used to temporarily connect this plug to a 2-contact ungrounded receptacle.

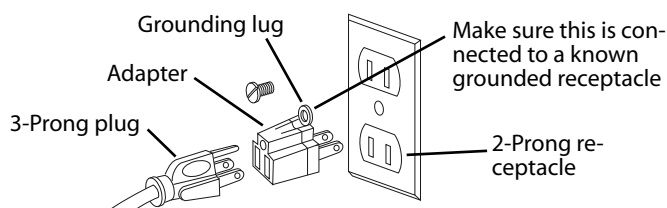

Figure 10 – 2-Prong receptacle with adapter

The adapter has a rigid lug extending from it that **MUST** be connected to a permanent earth ground, such as a properly grounded receptacle box. **THIS ADAPTER IS PROHIBITED IN CANADA.**

CAUTION: In all cases, make certain the electrical receptacle in question is properly grounded. If you are not sure have a certified electrician check the electrical receptacle.

WARNING: This Bench Grinder is for indoor use only. To avoid serious injury, do not expose to rain or use in damp locations.

OPERATION

The Bench Grinder is designed for hand held grinding, sharpening, and cleaning operations.

WARNING: ALWAYS WEAR EYE PROTECTION! Hot sparks are produced during grinding operations.

1. The Power Switch must be in the "OFF" position.
2. Stand to the side of the Bench Grinder and plug in the power cord to a suitable power source.
3. Remain to the side of the Bench Grinder and turn it "ON" by pressing switch at the ON position.
4. Allow the grinding wheels to come up to a steady speed for at least one minute.
5. The Flexible Work Light may be turned "ON" if desired.
6. Adjust the eyeshields. Place the workpiece on the appropriate tool rest for the desired operation.
7. Move the workpiece towards the grinding wheel until it lightly touches. Move the workpiece back and forth across the front surface of the grinding wheel removing the amount of material desired.

WARNING: To avoid serious injury, never grind on the sides of the grinding wheels.

8. After completing the grinding operations, turn "OFF" the Bench Grinder by pressing switch at the "OFF" position.

CAUTION: It will take a few minutes for the grinding wheels to come to a complete stop.

9. Turn "OFF" the Flexible Work Light.

CAUTION: The Flexible Work Light housing will remain hot for a few minutes after turning it "OFF".

10. Avoid contact with housing until it is cool. Unplug the Bench Grinder from the power source.

CHANGING THE GRINDING WHEEL

Refer to Figure 11, page 10.

Due to normal wear, both wheels will need to be replaced occasionally. See Figure 11.

1. Turn the power switch "OFF" and unplug the power cord from its power source
2. Rotate the eyeshields to the "UP" position for access to the tool rests.
3. Remove the screws (G) holding the wheel covers (H) to the bench grinder.
4. Remove the wheel covers.
5. Place a small wooden wedge between the abrasive wheel (I) and tool rest to prevent the wheels from rotating.

OPERATION (CONTINUED)

6. Remove the right side grinding wheel by turning the locknut in the counterclockwise direction with a wrench (not included). The left side wheel can be removed by turning the locknut (K) in the clockwise direction.
7. Remove the outer wheel flange (L) and then remove the abrasive wheel (I) from the arbor shaft (M).

CAUTION: The new abrasive wheel to be put onto the Bench Grinder must be have a higher R.P.M. rating than the Bench Grinder. The abrasive wheel must have a 6" diameter with a 1/2" bore diameter for the arbor shaft. The label on the side of the abrasive wheels must stay on, DO NOT remove this label.

8. Replace the abrasive wheel, outer wheel flange, and the locknut in reverse order from removal.

WARNING: DO NOT OVER-TIGHTEN the lock nut as this may damage the abrasive wheel and cause serious injury to the operator.

MAINTENANCE

WARNING: Turn the power switch "OFF" and unplug the power cord from its power source prior to any maintenance.

LUBRICATION

The Bench Grinder has sealed lubricated bearings in the motor housing that do not require any additional lubrication from the operator.

CLEANING

With the Bench Grinder unplugged, rotate the abrasive wheels slowly and inspect for any damage or trapped shavings.

WARNING: REPLACE the abrasive wheels if there is any damage at all. FAILURE to replace a damaged wheel can cause serious injury to the operator.

CAUTION: DO NOT USE FLAMMABLE MATERIALS to clean the Bench Grinder. A clean dry rag or brush is all that is needed to remove dust and debris buildup.

WARNING: Repairs to the Bench Grinder should be performed by trained personnel only. Contact your dealer for authorized service. Unauthorized repairs or replacement with non-factory parts could cause serious injury to the operator and damage to the Bench Grinder.

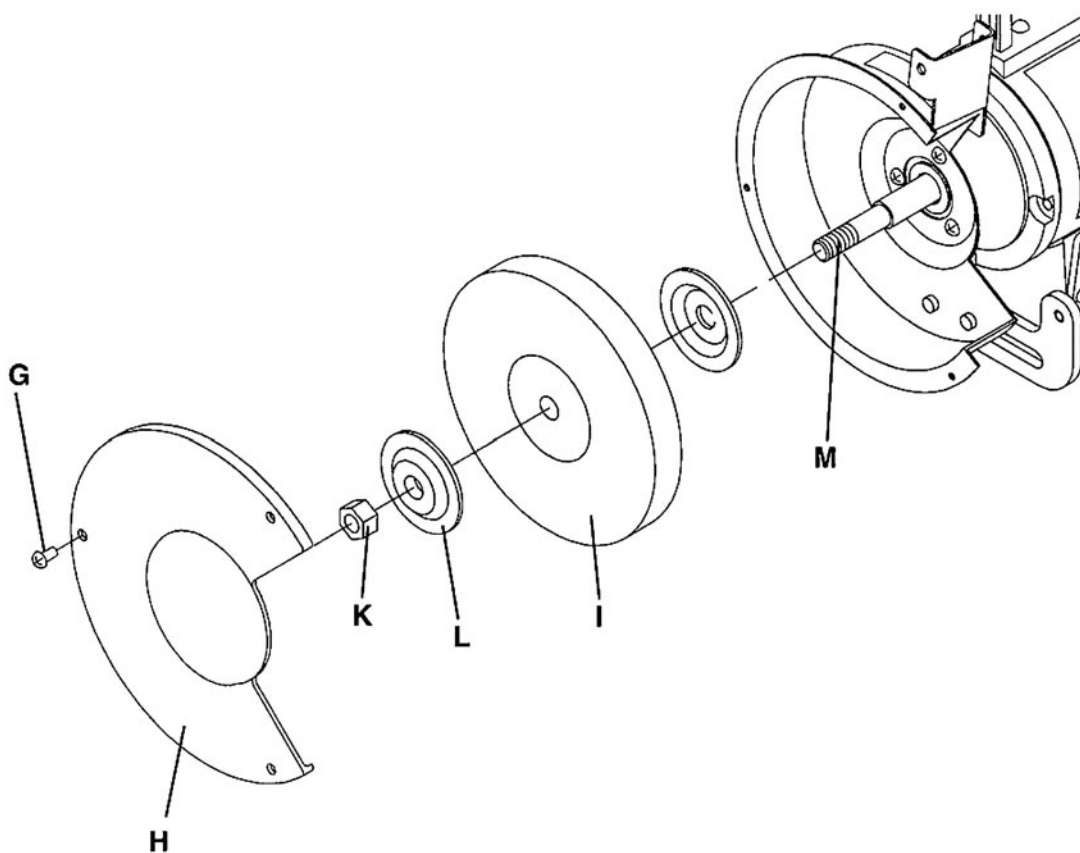

Figure 11 - Changing the Grinding Wheel

TROUBLESHOOTING

WARNING: TO PREVENT INJURY TO YOURSELF or damage to the Bench Grinder, turn the switch to the "OFF" position and unplug the power cord from the electrical receptacle before making any adjustments.

SYMPTOM	POSSIBLE CAUSE(S)	CORRECTIVE ACTION
Motor does not run	<ol style="list-style-type: none"> 1. Machine not plugged in 2. Power switch in "OFF" position 3. Power cord is faulty 4. Fuse or circuit breaker are open 5. Damaged motor 	<ol style="list-style-type: none"> 1. Machine not plugged in 2. Power switch in "OFF" position 3. Power cord is faulty 4. Fuse or circuit breaker are open 5. Damaged motor
Motor does not have full power	<ol style="list-style-type: none"> 1. Incorrect line voltage 2. Damaged motor 	<ol style="list-style-type: none"> 1. Incorrect line voltage 2. Damaged motor
Motor runs hot	<ol style="list-style-type: none"> 1. Motor is overloaded 2. Poor air circulation around motor 	<ol style="list-style-type: none"> 1. Motor is overloaded 2. Poor air circulation around motor
Motor stalls or runs slow	<ol style="list-style-type: none"> 1. Motor is overloaded 2. Poor air circulation around motor 	<ol style="list-style-type: none"> 1. Motor is overloaded 2. Poor air circulation around motor
Fuse blows or circuit breaker trips	<ol style="list-style-type: none"> 1. Motor overloaded 2. Overloaded electrical circuit 3. Wrong fuse or circuit breaker 4. Undersized or excessive length of extension cord, see manual 5. Grinding wheels are blocked 	<ol style="list-style-type: none"> 1. Motor overloaded 2. Overloaded electrical circuit 3. Wrong fuse or circuit breaker 4. Undersized or excessive length of extension cord, see manual 5. Grinding wheels are blocked

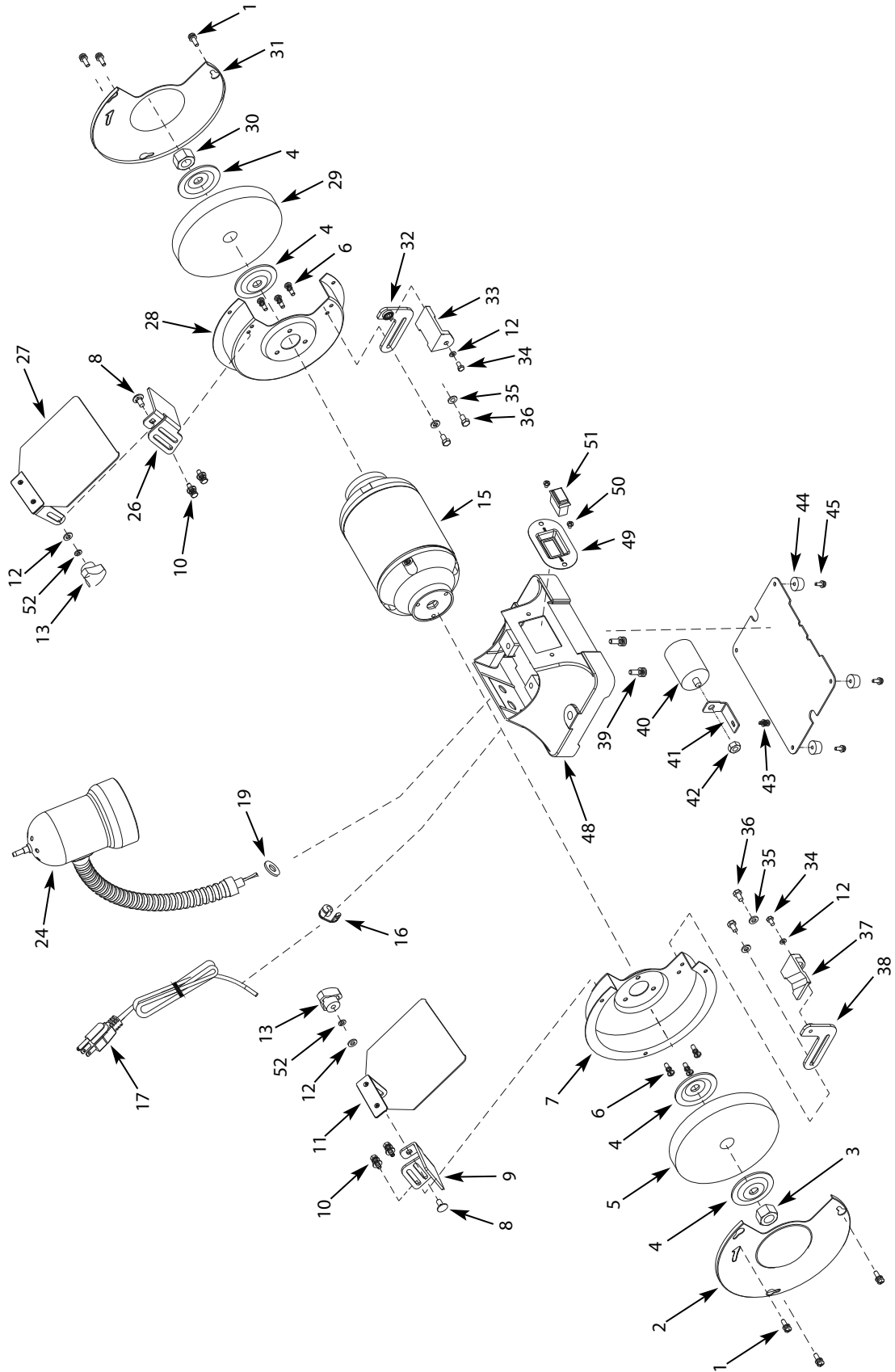

Figure 12 – Repair Parts Illustration for 6" Bench Grinder with Light

REPAIR PARTS LIST FOR 6" BENCH GRINDER WITH LIGHT

Ref. No.	Description	Part No.	Qty	Ref. No.	Description	Part No.	Qty.
1	Phillips Screw+Spring Washer+Flat Washer M5x12	*	6	30	Hex Nut, I Type M12	9642703.01	1
2	Left Guard Cover	9642689.01	1	31	Right Guard Cover	9642704.01	1
3	Hex Nut, I Type M12 Left	9642690.01	1	32	Right Tool Rest Bracket	9642705.01	1
4	Flange	9642691.01	4	33	Right Tool Rest	9642706.01	1
5	Grinding Wheel, 6", 60 Grit	9602033.00	1	34	Hex Bolt M6x20	*	2
6	Phillips Screw+Spring Washer M5x10	*	6	35	Flat Washer M8	*	4
7	Left Guard	9642692.01	1	36	Hex Bolt M8x12	*	4
8	Carriage Bolt M6x12	*	2	37	Left Tool Rest	9642707.01	1
9	Left Spark Deflector	9642693.01	1	38	Left Tool Rest Bracket	9642708.01	1
10	Hex Bolt+ Spring Washer+Flat Washer M5x10	*	4	39	Phillips Screw + Spring Washer M6x18	*	2
11	Left Eyeshield	9642694.01	1	40	Capacitor	9642709.01	1
12	Flat Washer M6	*	4	41	Capacitor Support	9642710.01	1
13	Locking Knob	9642695.01	2	42	Hex Nut, I Type M8	*	1
15	Motor Assembly	N/A	1	43	Phillips Screw + Spring Washer + Flat Washer M4x8	*	3
16	Cord Clip	9642696.01	1	44	Rubber Foot	9642711.01	4
17	Power Cord	9642697.01	1	45	Phillips Screw + Flat Washer M4x12	*	4
20	Base Plate	9642698.01	1	48	Base	N/A	1
24	Light	9642699.01	1	49	Switch Plate	9642712.01	1
26	Right Spark Deflector	9642700.01	1	50	Switch	9642713.01	1
27	Right Eyeshield	9642701.01	1	51	Phillips Screw M4x8	*	2
28	Right Guard	9642702.01	1	52	Spring Washer M6	*	2
29	Grinding Wheel, 6", 36 Grit	9602034.00	1				

(Δ) Not shown.

(N/A) Not available as repair part.

(*) Standard hardware item, available locally.

PALMGREN WARRANTY

C.H. Hanson / Palmgren warrants their products to be free of defects in material or workmanship. This warranty does not cover defects due directly or indirectly to misuse, abuse, normal wear and tear, failure to properly maintain the product, heated, ground or otherwise altered, or used for a purpose other than that for which it was intended.

The warranty does not cover expendable and/or wear part (i.e. v-belts, screws, abrasives, jaws), damage to tools arising from alteration, abuse or use other than their intended purpose, packing and freight. The duration of this warranty is expressly limited to the terms noted below beginning from the date of delivery to the original user.

The Palmgren branded items carry the following warranties on parts:

All vises, clamps, positioning tables, tombstones, jack screws and vise accessories - LIFETIME.

All bench grinders, drill presses, tapping machines, band saws, lathes, milling machines, arbor presses, abrasive finishing machines and work stands - 3 YEARS.

The obligation of C.H. Hanson / Palmgren is limited solely to the repair or replacement, at our option, at its factory or authorized repair agent of any part that should prove inoperable. Purchaser must lubricate and maintain the product under normal operating conditions at all times. Prior to operation become familiar with product and the included materials, i.e. warnings, cautions and manuals.

Failure to follow these instructions will void the warranty.

This warranty is the purchaser's exclusive remedy against C.H. Hanson for any inoperable parts in its product. Under no circumstances is C.H. Hanson liable for any direct, indirect, incidental, special or consequential damages including loss of profits in any way related to the use or inability to use our products. This warranty gives you specific legal rights which may vary from state to state.

PALMGREN®

Palmgren - a C.H. Hanson Company
2000 N. Aurora Rd., Naperville, IL 60563 U.S.A.
or call 1-800-827-3398