



# PALMGREN®

## 12" DISC SANDER



***Read carefully and follow all safety rules and operating instructions before first use of this product.***



## DESCRIPTION

Palmgren 12" Disc Sander is constructed of rugged die cast aluminum and cast iron providing stability and vibration-free operation. The sander is used to sand, deburr, bevel and grind large workpieces of wood, plastic and metal.

The 12" diameter disc can be used to sand or bevel surfaces with the use of 0 to 45° scaled cast iron table. Features include a tilting table with miter gauge slot, dust collection chute and disc brake. The adjustable miter gauge can be used to guide the workpiece at any desired angle while sanding.

## UNPACKING

Check for shipping damage. If damage has occurred, a claim must be filed with carrier. Check for completeness. Immediately report missing parts to dealer.

The sander comes assembled as one unit.

## SPECIFICATIONS

Disc diameter	12"
Disc table dimensions	8 <sup>3</sup> / <sub>8</sub> x 16"
Disc table tilts	0 to 45°
Disc dust chute diameter	2.06"
Disc speed	1725 RPM
Base dimensions	10 x 13"
Overall size	17 <sup>3</sup> / <sub>4</sub> x 20 <sup>7</sup> / <sub>8</sub> x 15 <sup>3</sup> / <sub>4</sub> "
Switch	SP, Locking rocker
Motor	3/4 HP, 120 V, 8.0 Amps
Weight	65 lbs
Shipping weight	71 lbs

## SAFETY RULES

**WARNING:** For your own safety, read all of the instructions and precautions before operating tool.



**PROPOSITION 65 WARNING:** Some dust created by using power tools contain chemicals known to the state of California to cause cancer, birth defects or other reproductive harm.

Some examples of these chemicals are:

- Lead from lead-based paints.
- Crystalline silica from bricks and cement and other masonry products.
- Arsenic and chromium from chemically-treated lumber.

Your risk from these exposures varies, depending on how often you do this type of work. To reduce your exposure to these chemicals: work in a well ventilated area and work with approved safety equipment. Always wear OSHA/NIOSH approved, properly fitting face mask or respirator when using such tools.

**WARNING:** Always follow proper operating procedures as defined in this manual even if you are familiar with the use of this or similar tools. Remember that being careless for even a fraction of a second can result in severe personal injury.

### BE PREPARED FOR JOB

- Wear proper apparel. Do not wear loose clothing, gloves, neckties, rings, bracelets or other jewelry which may get caught in moving parts of machine.
- Wear protective hair covering to contain long hair.

- Wear safety shoes with non-slip soles.
- Wear safety glasses complying with United States ANSI Z87.1. Everyday glasses have only impact resistant lenses. They are **NOT** safety glasses.
- Wear face mask or dust mask if operation is dusty.
- Be alert and think clearly. Never operate power tools when tired, intoxicated or when taking medications that cause drowsiness.

### PREPARE WORK AREA FOR JOB

- Keep work area clean. Cluttered work areas invite accidents.
- Do not use power tools in dangerous environments. Do not use power tools in damp or wet locations. Do not expose power tools to rain.
- Work area should be properly lighted.
- Proper electrical receptacle should be available for tool. Three-prong plug should be plugged directly into properly grounded, three-prong receptacle.
- Extension cords should have a grounding prong and the three wires of the extension cord should be of the correct gauge.
- Keep visitors at a safe distance from work area.
- Keep children out of workplace. Make workshop childproof. Use padlocks, master switches or remove switch keys to prevent any unintentional use of power tools.

### TOOL SHOULD BE MAINTAINED

- Always unplug tool prior to inspection.
- Consult manual for specific maintaining and adjusting procedures.
- Keep tool lubricated and clean for safest operation.
- Remove adjusting tools. Form habit of checking to see that adjusting tools are removed before switching machine on.
- Keep all parts in working order. Check to determine that the guard or other parts will operate properly and perform their intended function.
- Check for damaged parts. Check for alignment of moving parts, binding, breakage, and mounting or any other condition that may affect a tool's operation.
- A guard or other damaged part should be properly repaired or replaced. Do not perform makeshift repairs. (Use parts list provided to order repair parts.)

### KNOW HOW TO USE TOOL

- Use right tool for job. Do not force tool or attachment to do a job for which it was not designed.
- Disconnect tool when changing abrasive disc.
- Avoid accidental start-up. Make sure that the tool is in the OFF position before plugging in.
- Do not force a tool. It will work most efficiently at the rate for which it was designed.
- Keep hands away from moving parts and sanding surfaces.
- Never leave tool running unattended. Turn the power off and do not leave tool until it comes to a complete stop.
- Do not overreach. Keep proper footing and balance.
- Never stand on tool. Serious injury could occur if tool is tipped or if disc is unintentionally contacted.
- Know your tool. Learn the tool's operation, application and specific limitations.
- Use recommended accessories (refer to page 7). Use of improper accessories may cause risk of injury to persons.
- Handle workpiece correctly. Protect hands from possible injury.

## SAFETY RULES (CONTINUED)

- Turn machine off if it jams. Belt jams when it digs too deeply into workpiece. (Motor force keeps it stuck in the work.)
- Support workpiece with miter gauge or work table.
- Maintain 1/16" maximum clearance between table and sanding disc.

**CAUTION:** Think safety! Safety is a combination of operator common sense and alertness at all times when tool is being used.

**WARNING:** Do not attempt to operate tool until it is completely assembled according to instructions.

## INSTALLATION

Refer to Figures 1, 2 and 3.

**WARNING:** All electrical connections must be performed by a qualified electrician.

### POWER SOURCE

The motor is designed for operation on the voltage and frequency specified. Normal loads will be handled safely on voltages not more than 10% above or below the specified voltage.

Running the unit on voltages which are not within the range may cause overheating and motor burn-out. Heavy loads require that the voltage at motor terminals be no less than the voltage specified. Power supply to the motor is controlled by a single pole locking rocker switch. Remove the key to prevent unauthorized use.

### GROUNDING INSTRUCTIONS

**WARNING:** Improper connection of equipment grounding conductor can result in the risk of electrical shock. Equipment should be grounded while in use to protect operator from electrical shock. Check with a qualified electrician if grounding instructions are not understood or if in doubt as to whether the tool is properly grounded.

This tool is equipped with an approved 3-conductor cord rated at 150V and a 3-prong grounding type plug (See Figure 1) for your protection against shock hazards.

Grounding plug should be plugged directly into a properly installed and grounded 3-prong grounding-type receptacle, as shown (Figure 1).

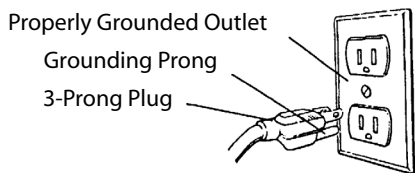

**Figure 1 – 3-Prong Receptacle**

Do not remove or alter grounding prong in any manner. In the event of a malfunction or breakdown, grounding provides a path of least resistance for electrical shock.

**WARNING:** Do not permit fingers to touch the terminals of plug when installing or removing from outlet.

Plug must be plugged into matching outlet that is properly installed and grounded in accordance with all local codes and ordinances. Do not modify plug provided. If it will not fit in outlet, have proper outlet installed by a qualified electrician.

Inspect tool cords periodically, and if damaged, have repaired by an authorized service facility.

Green (or green and yellow) conductor in cord is the grounding

wire. If repair or replacement of the electric cord or plug is necessary, do not connect the green (or green and yellow) wire to a live terminal.

Where a 2-prong wall receptacle is encountered, it must be replaced with a properly grounded 3-prong receptacle installed in accordance with National Electric Code and local codes and ordinances.

**WARNING:** This work should be performed by a qualified electrician.

A temporary 3-prong to 2-prong grounding adapter (See Figure 2) is available for connecting plugs to a two pole outlet if it is properly grounded.

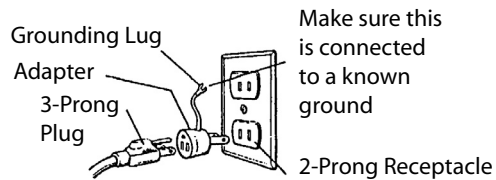

**Figure 2 – 2-Prong Receptacle with Adapter**

Do not use a 3-prong to 2-prong grounding adapter unless permitted by local and national codes and ordinances.

(A 3-prong to 2-prong grounding adapter is not permitted in Canada.) Where permitted, the rigid green tab or terminal on the side of the adapter must be securely connected to a permanent electrical ground such as a properly grounded water pipe, a properly grounded outlet box or a properly grounded wire system.

Many cover plate screws, water pipes and outlet boxes are not properly grounded. To ensure proper ground, grounding means must be tested by a qualified electrician.

### EXTENSION CORDS

- The use of any extension cord will cause some drop in voltage and loss of power.
- Wires of the extension cord must be of sufficient size to carry the current and maintain adequate voltage.
- Use the table to determine the minimum wire size (A.W.G.) extension cord.
- Use only 3-wire extension cords having 3-prong grounding type plugs and 3-pole receptacles which accept the tool plug.
- If the extension cord is worn, cut or damaged in any way, replace it immediately.

### EXTENSION CORD LENGTH

Wire Size .....	A.W.G.
Up to 25 ft. ....	18
25 to 50 ft. ....	16
50 to 100 ft. ....	14

**NOTE:** Using extension cords over 100 ft. long is not recommended.

### ELECTRICAL CONNECTIONS

**WARNING:** All electrical connections must be performed by a qualified electrician. Make sure tool is off and disconnected from power source while motor is mounted, connected, reconnected or anytime wiring is inspected.

Motor is assembled with approved, 3-conductor cord to be used at 120 volts. Motor is prewired at the factory for 120 volts.

## INSTALLATION (CONTINUED)

### MOUNTING SANDER

Refer to Figure 3.

Choose a suitable location to mount the sander. The sander must be installed in a place with ample lighting and correct power supply. To install sander:

- The sander must be placed on a firm, level surface.
- Make sure there is plenty of room for moving the workpiece. There must be enough room that neither operators nor bystanders will have to stand in line with the wood while using the tool.
- Sander can be installed on a workbench or a tool stand (see Recommended Accessories, page 7) using bolts, lock washers and hex nuts (not supplied).
- To bolt sander to a workbench or tool stand, the feet, bolts, washers and nuts (Fig. 4, Ref. Nos. 16, 17 and 18) must be removed.
- Figure 3 shows the base dimensions, mounting holes and required space.

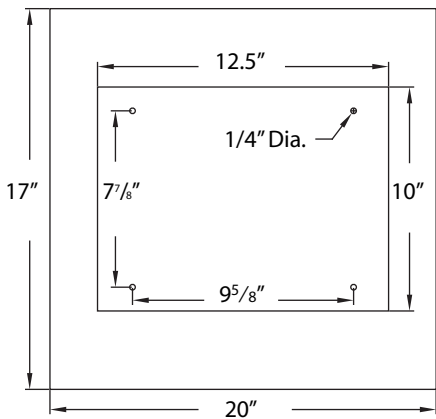

Figure 3 – Base Dimension and Required Space

## OPERATION

Refer to Figure 4, page 6.

**WARNING:** Operation of any power tool can result in foreign objects being thrown into eyes which can result in severe eye damage. Always wear safety goggles complying with United States ANSI Z87.1 (shown on package) before commencing power tool operation.

**CAUTION:** Always observe the following safety precautions:

- Whenever adjusting or replacing any parts on the tool, turn switch off and remove the plug from power source.
- Recheck table handles and bolt. They must be tightened securely.
- Make sure all guards are properly attached and securely fastened.
- Make sure all moving parts are free and clear of any interference.
- Make sure all fasteners are tight and have not vibrated loose.
- With power disconnected, test operation by hand to verify clearance and adjust if necessary.
- Always wear eye protection or face shield.

- After turning switch on, always allow disc to come up to full speed before sanding or grinding.
- Be sure disc runs counterclockwise.
- Keep your hands clear of abrasive disc and all moving parts.
- For optimum performance, do not stall motor or reduce speed. Do not force the work into the abrasive.
- Support workpiece with work table.
- Never push a sharp corner of workpiece rapidly against disc. Abrasive backing may tear.
- Replace abrasives when they become loaded (glazed) or frayed.
- When grinding metal, move workpiece across abrasive to prevent heat build-up.
- Never attempt wet sanding. If workpiece becomes too hot to handle, cool it in water.

### ON/OFF SWITCH

Refer to Figure 4, page 6.

The ON/OFF switch (Ref. No. 9) is located on the motor junction box. To turn the sander ON, pull the switch to the up position. To turn the sander OFF, push the switch to the down position.

The sander can be locked from unauthorized use by locking the switch. To lock the switch:

1. Turn the switch to OFF position and disconnect sander from power source.
  2. Pull the key out. The switch cannot be turned on with the key removed.
- NOTE:** Should the key be removed from the switch at the ON position, the switch can be turned off but cannot be turned on again.
3. To replace key, slide key into the slot on switch until it snaps.

### ADJUSTING DISC TABLE ANGLE

**WARNING:** Sander must be disconnected from power source before making adjustments.

Refer to Figure 4, page 6

Disc table (Ref. No. 4) is adjustable from 0 to 45° for beveled work.

1. To adjust the disc table, loosen the two handles (Ref. No. 8) and pivot to the desired angle.
2. Use the scale on disc table trunnions (Ref. No. 6) to set table from 0 to 45° from abrasive disc.
3. When disc table is at desired angle, lock it into position by securely tightening the handles.
4. To check accuracy, place combination square against disc and table top surface. Loosen and adjust pointer (Ref. No. 7) to zero.

### TABLE ALIGNMENT

**WARNING:** Sander must be disconnected from power source before making adjustments.

Refer to Figure 4, page 6

- Table must be positioned so that the sanding disc does not touch the table.
- The gap between table and disc must not exceed 1/16"
- The miter gauge slot must be square to the disc.

To align:

1. Loosen screws (Ref. No. 11).
2. Use scale and square to set 1/16" gap between table and disc. Make sure slot is square to disc.
3. Tighten screws.

## OPERATION (CONTINUED)

### ABRASIVE DISC FINISHING

- Abrasive disc sanding is well suited for finishing small flat surfaces and convex edges.
- Move workpiece across down side (left) of abrasive disc.
- Abrasive disc moves fastest and removes more material at outer edge.
- For accuracy, use miter gauge.

### USING MITER GAUGE

- Use the miter gauge for securing the work and holding the proper angle while sanding.
- Adjust angle by repositioning the miter gauge scale and locking it into place with knob.
- Check accuracy of miter gauge scale.
- Use a combination square to adjust miter gauge square to disc. Place square against disc and face of miter gauge. Indicator should be at zero. Loosen screw and reposition indicator if necessary.

### REPLACING ABRASIVE DISC

**WARNING:** Sander must be disconnected from power source before making adjustments.

Refer to Figure 4, page 6.

1. Remove disc table and dust chute. Remove old abrasive disc by peeling it from the aluminum disc. Removing aluminum disc from motor shaft is not necessary.
2. Clean aluminum disc if necessary. Select the proper abrasive disc and apply to aluminum disc.
  - Additional abrasive discs are available (See Recommended Accessories, page 7).
3. Replace dust chute and disc table.

### DISC BRAKE

Refer to Figure 4.

This sander is equipped with a disc brake (Ref. No. 10). Press down on brake handle to stop disc.

**CAUTION:** Apply brake only after turning sander OFF. Applying brake when sander is ON may damage motor.

## MAINTENANCE

**WARNING:** Make certain that the unit is disconnected from power source before attempting to service or remove any component.

### CLEANING

- Keep machine and workshop clean. Do not allow sawdust to accumulate on the tool.
  - Operate tool with dust collector to keep dust from accumulating.
- WARNING:** After sanding wood or non-metallic material, always clean dust collector and guards of sawdust before grinding metal. Sparks could ignite debris and cause a fire.
- Be certain motor is kept clean and is frequently vacuumed free of dust.
  - Use soap and water to clean painted parts, rubber parts and plastic guards.

### LUBRICATION

- The shielded ball bearings in this tool are permanently lubricated at the factory. They require no further lubrication.
- When operation seems stiff, a light coat of paste wax applied to the work table will make it easier to feed the work while finishing.

### KEEP TOOL IN REPAIR

- If power cord is worn, cut or damaged in any way, have it replaced immediately.
- Replace worn abrasives when needed.
- Replace any damaged or missing parts. Use parts list to order parts.
- Any attempt to repair motor may create a hazard unless repair is done by a qualified service technician.

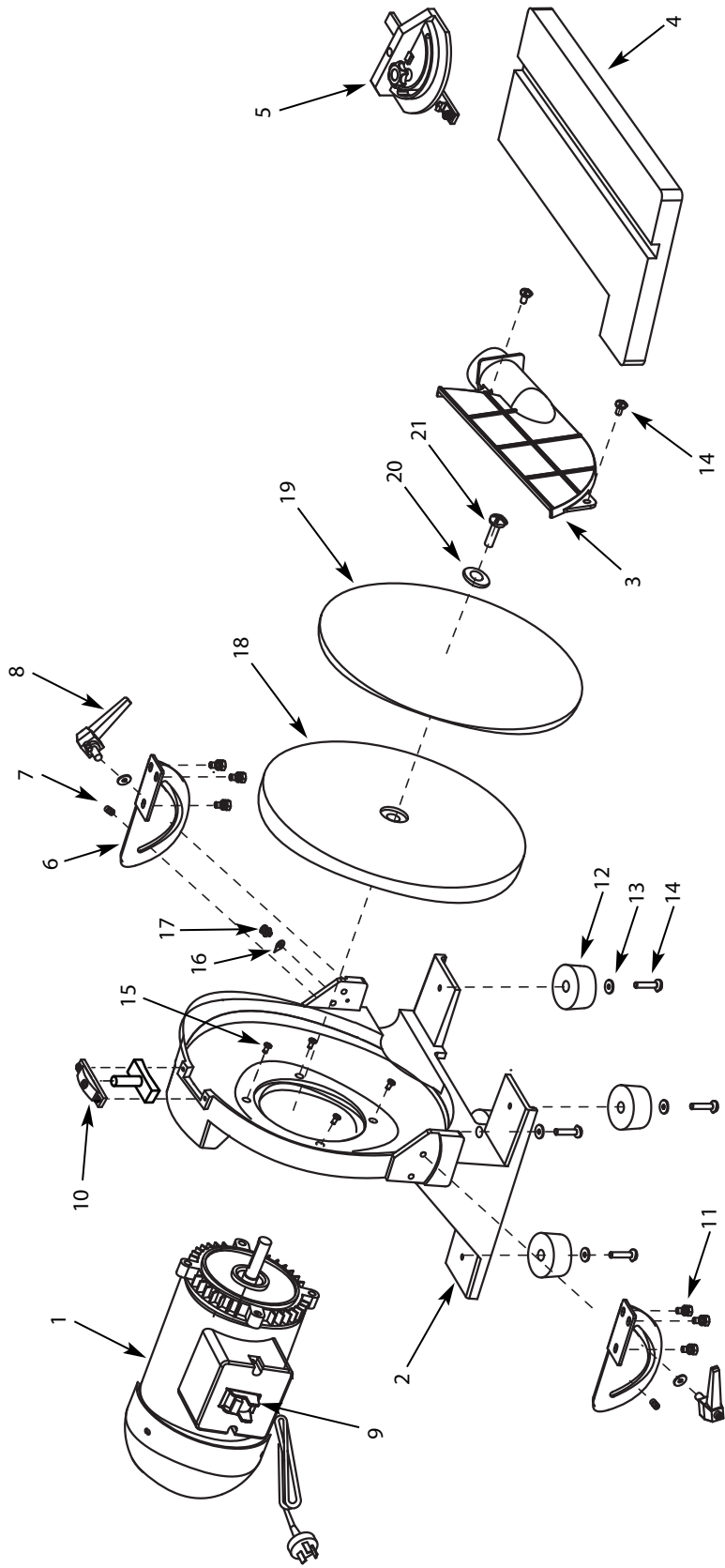

Figure 4 – Repair Parts Illustration for 12" Disc Sander

## REPAIR PARTS LIST FOR DISC SANDER

Ref. No.	Description	Part No.	Qty.	Ref. No.	Description	Part No.	Qty.
1	Motor assembly	9642348.01	1	16	Dial pointer	9626891.00	1
2	Base	N/A	1	17	Phillips screw, spring washer, flat washer M4 x 8	*	1
3	Dust cover	9642349.01	1	18	Disc	9642355.01	1
4	Disc table	9642350.01	1	19	Disc paper	1GLC7	1
5	Miter gauge assembly	9642356.01	1	20	Disc pad	9626904.00	1
6	Dial	9642351.01	2	21	Phillips Screw M6 x 20	*	1
7	Positioning pin	9642352.01	2	Δ	Operating Instructions and Parts Manual	9642347.01	
8	Locking knob	9642653.01	2		<b>Recommended Accessories</b>		
9	Locking switch	9642326.01	1		<b>Abrasive Discs 12" Diameter</b>		
10	Brake assembly	9642354.01	1		36 Grit	1GLC4	
11	Hex bolt and spring washer	*	6		50 Grit	1GLC6	
12	Rubber foot	9626893.00	4		80 Grit	1GLC8	
13	Flat washer M6	*	7		120 Grit	1GLD1	
14	Phillips screw M6 x 20	*	6		180 Grit	1GLD2	
15	Hex bolt and spring washer M8 x 25	*	4				

(Δ) Not shown.

(†) Not available as repair part.

(\*) Standard hardware item, available locally.

## PALMGREN WARRANTY

C.H. Hanson / Palmgren warrants their products to be free of defects in material or workmanship. This warranty does not cover defects due directly or indirectly to misuse, abuse, normal wear and tear, failure to properly maintain the product, heated, ground or otherwise altered, or used for a purpose other than that for which it was intended.

The warranty does not cover expendable and/or wear part (i.e. v-belts, screws, abrasives, jaws), damage to tools arising from alteration, abuse or use other than their intended purpose, packing and freight. The duration of this warranty is expressly limited to the terms noted below beginning from the date of delivery to the original user.

**The Palmgren branded items carry the following warranties on parts:**

**All vises, clamps, positioning tables, tombstones, jack screws and vise accessories - LIFETIME.**

**All bench grinders, drill presses, tapping machines, band saws, lathes, milling machines, arbor presses, abrasive finishing machines and work stands - 3 YEARS.**

The obligation of C.H. Hanson / Palmgren is limited solely to the repair or replacement, at our option, at its factory or authorized repair agent of any part that should prove inoperable. Purchaser must lubricate and maintain the product under normal operating conditions at all times. Prior to operation become familiar with product and the included materials, i.e. warnings, cautions and manuals.

**Failure to follow these instructions will void the warranty.**

This warranty is the purchaser's exclusive remedy against C.H. Hanson for any inoperable parts in its product. Under no circumstances is C.H. Hanson liable for any direct, indirect, incidental, special or consequential damages including loss of profits in any way related to the use or inability to use our products. This warranty gives you specific legal rights which may vary from state to state.

**PALMGREN**<sup>®</sup> *Palmgren - a C.H. Hanson Company*  
2000 N. Aurora Rd., Naperville, IL 60563 U.S.A.  
or call 1-800-827-3398