

Operating Manual

Version 2.1.8

Bench drilling machine

- B 24 H (13" Item No. 9680221)
- B 28 HB (16" Item No. 9680215)



Upright drilling machine

- B 28 H (16" Item No. 9680214)
- B 28 HV (16" Item No. 9680217)



Table of contents

1	Safety	
1.1	Safety warnings (warning notes)	6
1.1.1	Classification of hazards	6
1.1.2	Other pictograms	7
1.2	Proper use	8
1.3	Possible dangers caused by the bench drill and upright drill	8
1.4	Qualification of employees	9
1.4.1	Target group	9
1.4.2	Authorized persons	9
1.5	Safety measures during operation	10
1.6	Safety devices	10
1.7	Safety check	11
1.8	EMERGENCY-STOP button	12
1.9	Drilling table	12
1.10	Separating protective devices	13
1.10.1	Protective cover of the belt pulleys	13
1.10.2	Drill chuck guard	13
1.11	Personal protective equipment	13
1.12	Safety during operation	14
1.13	Safety during maintenance	14
1.13.1	Switching-off and securing the bench drill and upright drill	14
1.14	Use of lifting equipments	15
1.14.1	Mechanical maintenance work	15
1.15	Accident report	15
1.16	Electrical	15
2	Technical Data	
2.1	Power connection	16
2.2	Drilling capacity	16
2.3	Spindle	16
2.4	Drilling machine table	16
2.9	Emissions	17
2.5	Required space	17
2.6	Speeds	17
2.7	Environmental conditions	17
2.8	Operating material	17
2.10	Dimensions B24H	19
2.11	Dimensions B28HB	20
2.12	Dimensions B28H	21
2.13	Dimensions B28HV	22
3	Assembly	
3.1	Scope of delivery	23
3.2	Transport	23
3.3	Storage	24
3.4	Installation and assembly	25
3.4.1	Site requirements	25
3.4.2	Assembly	26
3.4.3	Assembly of the drilling machine table B24H (B28H B)	27
3.4.4	Assembly of the drilling machine table B28H (Vario)	27
3.5	Installation	29
3.5.1	Mounting	30
3.5.2	Installation drawings	31

3.6	First use	33
4	Operation	
4.1	Safety	34
4.2	Control and indicating elements	34
4.2.1	Drilling machine B24H B28 HB.....	34
4.2.2	Drilling machine B28H B28HV.....	35
4.2.3	Control panel B24H.....	36
4.2.4	Control panel B28H (Vario), B28HB.....	36
4.3	Turn the machine on B24H / B28H / B28HB	38
4.4	Turn the machine on B28HV	38
4.5	Turn the machine off B24H / B28H / B28HB	38
4.6	Turn the machine off B28H Vario.....	38
4.7	Speed variation	39
4.7.1	Speed table B24H	40
4.7.2	Speed table B28H - B28HB.....	40
4.7.3	Speed table B28HV	41
4.8	Drill depth stop	41
4.9	Removing, mounting of drill chucks and drills	42
4.9.1	Keyless drill chuck.....	42
4.9.2	Removing the drill chuck	42
4.9.3	Removing the tool or drill chuck with the integrated drill drift on the B28H (B, Vario)	43
4.9.4	Mounting the drill chuck B24H and B28H (B, Vario)	43
4.10	Cooling	44
4.11	Before starting the working process	45
4.12	During the working process.....	45
5	Determining the cutting speed and the speed	
5.1	Table cutting speeds / infeed	46
5.2	Speed table	46
5.3	Examples to calculatory determine the required speed for your drilling machine	48
6	Maintenance	
6.1	Safety	50
6.1.1	Preparation.....	50
6.1.2	Restarting.....	50
6.2	Inspection and maintenance	50
6.3	Repair.....	53
7	Spare parts - B24H B28H B28HB B28HV	
7.1	B24H	54
7.1.1	Drilling head B24H	54
7.1.2	Column and drilling table B24H.....	55
7.1.3	Pulleys B24H.....	56
7.1.4	Parts list B24H.....	56
7.1.5	Wiring diagram B24H - 115V, 60 Hz	59
7.2	B28H B28HB	60
7.2.1	Drilling head B28H B28HB	60
7.2.2	Column and drilling table B28H.....	61
7.2.3	Column and drilling table B28HB	62
7.2.4	Pulleys B28H B28HB.....	63
7.2.5	Parts list B28H B28HB	64
7.3	B28HV	67
7.3.1	Drilling head B28HV	67
7.4	Column and drilling table B28HV	68
7.4.1	Pulleys B28HV	69
7.4.2	Parts list B28HV	70
7.4.3	Wiring diagram B28H B28HB - 115V, 60Hz	73

7.4.4	Wiring diagram B28HV, page 1 - 230V, 60Hz	74
7.4.5	Wiring diagram B28HV, page 2 - 230V, 60Hz	75
8	Troubleshooting	
9	Appendix	
9.1	Copyright	78
9.2	Terminology/Glossary	78

Preface

Dear customer,

Thank you very much for purchasing a product made by company.

Company metal working machines offer a maximum of quality, technically company solutions and convince by an outstanding price performance ratio. Continuous enhancements and product innovations guarantee state-of-the-art products and safety at any time.

Before commissioning the machine please thoroughly read these operating instructions and get familiar with the machine. Please also make sure that all persons operating the machine have read and understood the operating instructions beforehand.

Keep these operating instructions in a safe place nearby the machine.

Information

The operating instructions include indications for safety-relevant and proper installation, operation and maintenance of the machine. The continuous observance of all notes included in this manual guarantee the safety of persons and of the machine.

The manual determines the intended use of the machine and includes all necessary information for its economic operation as well as its long service life.

In the paragraph "Maintenance" all maintenance works and functional tests are described which the operator must perform in regular intervals.

The illustration and information included in the present manual can possibly deviate from the current state of construction of your machine. Being the manufacturer we are continuously seeking for improvements and renewal of the products. Therefore, changes might be performed without prior notice. The illustrations of the machine may be different from the illustrations in these instructions with regard to a few details. However, this does not have any influence on the operability of the machine.

Therefore, no claims may be derived from the indications and descriptions. Changes and errors are reserved!



Your suggestion with regard to these operating instructions are an important contribution to optimising our work which we offer to our customers. For any questions or suggestions for improvement, please do not hesitate to contact us.

If you have any further questions after reading these operating instructions and you are not able to solve your problem with a help of these operating instructions, please contact your specialised dealer or

C.H.HANSON
 2000 North Aurora Rd.
 Naperville,IL 60563
 Call 800-827-3398

1 Safety

Glossary of symbols

	gives further advice
	calls on you to get in action
	enumeration

This part of the operating manual

- does explain the meaning and how to use the warning references contained in this operating manual,
- does explain how to use the bench and upright drilling machine,
- highlights the dangers that might arise for you and others if these instructions are not followed thoroughly,
- informs you on how to prevent dangers.

In addition to this operating manual, please note

- applicable laws and regulations,
- legal regulations for preventing an accident,
- the prohibition, warning and mandatory signs as well as the warning notes on the bench drilling machine.

Consult OSHA, state and local regulations in order to determine compliance, danger and risks to the operator.

ALWAYS KEEP THIS DOCUMENT CLOSE TO THE BENCH DRILL AND UPRIGHT DRILL FOR FUTURE REFERENCE.

INFORMATION

If you are unable to solve a problem using this manual, please contact us for advice:





Exclusive USA Agent
C.H.HANSON
2000 North Aurora Rd.
Naperville, IL 60563
Call 800-827-3398

1.1 Safety warnings (warning notes)

1.1.1 Classification of hazards

We classify the safety warnings into various levels. The table below gives an overview of the classification of symbols (pictogram) and warning signs for each specific danger and its (possible) consequences.

Pictogram	warning alert	definition/consequence
	DANGER!	Threatening danger that will cause serious injury or death to people.
	WARNING!	Risk: A danger that might cause serious injury or death to a person.
	CAUTION!	Danger or unsafe procedure that might cause injury to people or damage to property.
	ATTENTION!	Situation that could cause damage to the machine and to the product and other types of damages. No risk of injury to people.
	Information	Application advice and other important or useful information and notes. No dangerous or harmful consequences for people or objects.

In the case of specific dangers, we replace the pictogram





General danger



with a warning of

injuries to hands,



hazardous electrical voltage,

or



rotating parts.

1.1.2 Other pictograms

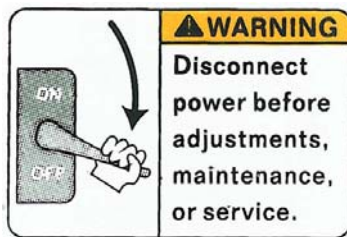

Warning of automatic start-up!



Disconnect main power!



Activation forbidden!



Use ear protection!



Use protective boots!



Use protective gloves!



Wear a safety suit!

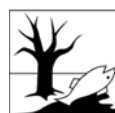

Protect the environment!



Use safety glasses!



Contact address

1.2 Proper use

WARNING!

In the event of improper use of the bench drill and upright drill

- there may be a risk to personnel,
 - there may be a risk to the machine and other items,
- correct functioning of the bench drill and upright drill may be affected.**



The bench drill and upright drill is designed and manufactured to be used in environments where there is no potential danger of explosion. The bench drill and upright drill is designed and manufactured to produce holes in cold metal or other not health hazardous or not burnable material by using a rotating cutting tool with several chucking grooves.

If the bench drill and upright drill is used in any way other than prescribed above, modified without authorization of company, then the bench drill and upright drill is being used improperly.

We do not take liability for damage caused through improper use.

We would like to accent that any modifications to the construction, or technical or technological modifications that have not been authorized by company will also expire the guarantee.

It is also part of proper use that

- the maximum values of the bench drill and upright drill are complied with,
- the operating manual is constantly observed,
- inspection and maintenance instructions are observed.

📖 "Technical Data" on page 16

WARNING!

Very serious injury due to improper use.

It is forbidden to make any modifications or alternations to the operating values of the bench drill and upright drill! They could endanger employees and cause damage to the bench drill and upright drill.



1.3 Possible dangers caused by the bench drill and upright drill

The bench drill and upright drill is state of the art.

Nevertheless, there is a residual risk as the bench drill and upright drill operates with

- high revolutions,
- rotating parts,
- electrical voltage and currents.

We have used construction resources and safety techniques to minimize the health risk to persons resulting from these hazards.

If the bench drill and upright drill is used and maintained by employees who are poorly qualified, then there might be a risk resulting from incorrect operation and unsuitable maintenance of the bench drill and upright drill.

INFORMATION

Everyone involved in the assembly, commissioning, operation and maintenance must

- be duly qualified,
- strictly follow this operating manual.



Due to improper use

- there is a risk for the employee,
- the machine and further property might be endangered,
- the function of the bench drill and upright drill could be effected.

Always disconnect the bench drill and upright drill if cleaning or maintenance work is being carried out.

WARNING!

The bench drill and upright drill may only be used with the safety devices activated.

Disconnect the bench drill and upright drill immediately whenever you detect a failure in the safety device or when they are not mounted!

All additional installations carried out by the operator must incorporate the safety devices prescribed.

This is your responsibility being the operator!

 "Safety devices" on page 10



1.4 Qualification of employees

1.4.1 Target group

This manual applies to

- the operators,
- the users,
- the maintenance staff.

Therefore, the warning notes refer to both operation and maintenance of the bench drill and upright drill.

Determine clearly and make a permanent decision in who will be responsible for the different activities on the machine (operation, maintenance and repair).

Vague and unclear assignment of responsibilities constitute a safety hazard!

Always disconnect the bench drill and upright drill from the main electrical power supply. This will prevent your machine from being used by unauthorized personnel.



1.4.2 Authorized persons

WARNING!

Incorrect use and maintenance of the bench drill and upright drill constitute a danger for the staff, objects and the environment.

Only authorized persons may operate the bench drill and upright drill!

Persons authorized to operate and maintain should be trained technical staff and instructed by the ones who are working for the operator and for the manufacturer.



The operator must

- train the staff,

Obligations of
the
operator

- instruct the staff in regular intervals (at least once a year) on
 - all safety standards that apply to the bench drill and upright drill,
 - the operation,
 - accredited technical guidelines,
- check the knowledge of the staff,
- document training / instructions,
- require the staff to confirm participation in training / instructions by means of a signature,
- check if the staff is aware of safety rules and dangers in the workplace so that they observe the operating manual.

The user must

- have followed a training on the operation of the bench drill and upright drill,
- know the function and performance,
- before commissioning
 - have read and understood the operating manual,
 - be familiar with all safety devices and regulations.

Obligations of the user

For working on the following machine parts, additional requirements are being applied:

- Electrical parts or operating agents: shall only be performed by an electrician or under the guidance and supervision of an electrician.

Further requirements to the qualification

Before starting work on electrical parts or operating agents, following measures are to be performed in the following order:

- ➔ Disconnect main electrical power.
- ➔ Ensure that the machine cannot be turned on again.
- ➔ Check that there is no voltage.

1.5 Safety measures during operation

CAUTION!

Risk due to inhaling of health hazardous dusts and mist.

Dependent on the material which need to be processed and the used auxiliaries dusts and mist may be caused which might impair you health.

Make sure that the generated health hazardous dusts and mist are safely sucked off at the point of origin and is dissipated or filtered from the working area. Use an appropriate suction unit.



CAUTION!

Risk of fire and explosion by using flammable materials or cooling lubricants.

Take additional preventive measures in order to safely avoid health hazards before processing flammable materials (e.g. aluminum, magnesium) or before using flammable additives (e.g. solvents).



1.6 Safety devices

Operate the bench drill and upright drill only with properly functioning safety devices.

Stop the bench drill and upright drill immediately if there is a failure in the safety device or if it is not functioning for some reason.

It is your responsibility!

If the safety device has been activated or has failed, the bench drill and upright drill must only be operated again when

- the cause of the failure has been removed,
- you have made sure that there is no existing danger for persons or objects.

WARNING!

If you bypass, remove or override a safety device in any other way, you are endangering yourself and other persons working on the bench drill and upright drill. The possible consequences are the following



- injuries due to components or parts of components flying off a high speed,
- contact with rotating parts,
- fatal electrocution.

WARNING!

The separating protective equipment which is made available and delivered together with the machine is designed to reduce the risk of workpieces or fractions of them which being expelled, but not to remove them completely.



The bench drill and upright drill includes the following safety devices:

- an EMERGENCY-STOP button,
- a drilling machine table with T-slots to fasten the workpiece or a vice,
- a protective cover for the pulleys with positioning switch.

1.7 Safety check

Check the bench drill and upright drill at least once per shift. Inform the person responsible immediately of any defect or change in the operation function.

Check all safety devices

- at the beginning of each shift (with the machine stopped),
- once a week (with the machine in operation),
- after every maintenance and repair work.

Check that the prohibition, warning and information labels as well as the markings on the bench drill and upright drill

- are legible (clean them, if necessary),
- are complete.

INFORMATION

Use the following overview to organize the inspections.



General inspection		
Item	Inspection	OK
Protective cover	Mounted, securely tightened and not damaged	
Signs, markings	Installed and legible	
Date:	Inspector (signature):	

Functional test		
Item	Inspection	OK
EMERGENCY-STOP push button	Once the emergency stop button is activated, the bench drill and upright drill should be switched off.	
Stop position switch protective cover V-belts	The bench drill and upright drill must not switch on, if the protective cover of the pulleys is opened.	
Date:	Inspector (signature):	

Functional test		
Item	Inspection	OK
drill chuck guard	The bench drill and upright drill must only switch on when the drill chuck protection is closed.	
Date:	Inspector (signature):	

1.8 EMERGENCY-STOP button

CAUTION!

After actuating the EMERGENCY-STOP button, the drill spindle will turn for a few seconds more, depending on the previously selected speed.

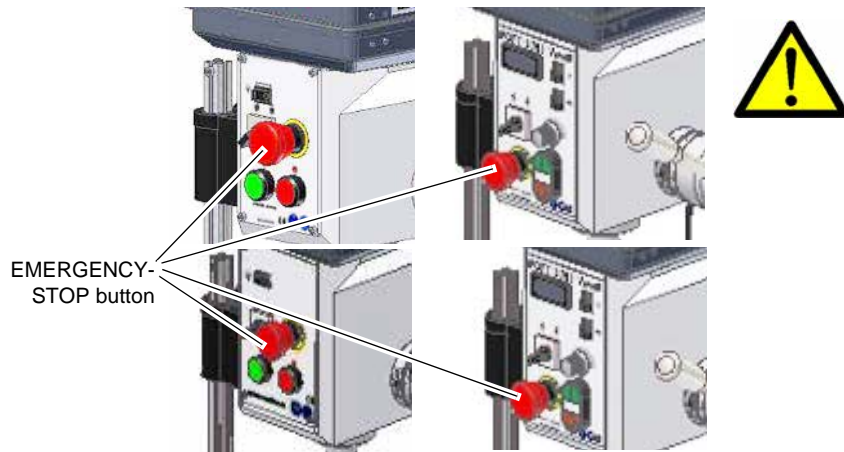

Fig. 1-1: EMERGENCY-STOP B24H, B28H, B28HV

1.9 Drilling table

The drilling table is equipped with T-slots for clamping blocks.

WARNING!

Risk of injury due to parts flying off at high speed. Securely fix the workpiece on the drilling table.

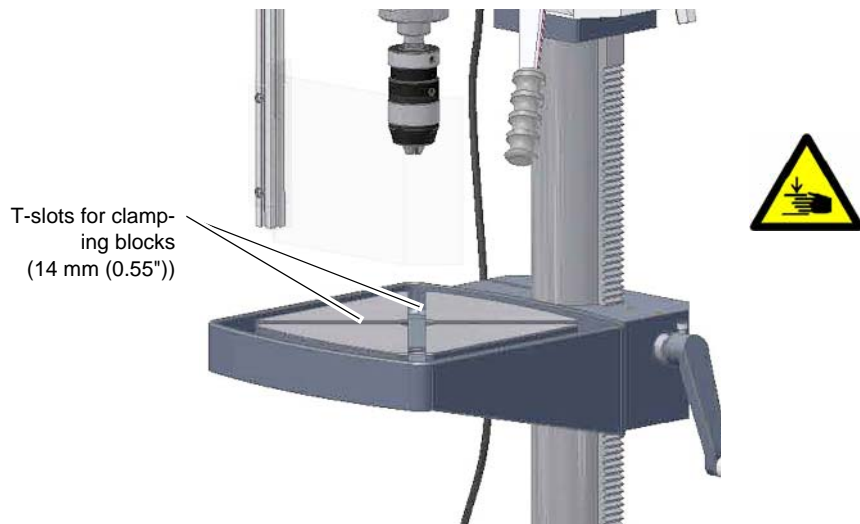

Img.1-2: Drilling table

1.10 Separating protective devices

1.10.1 Protective cover of the belt pulleys

A protective cover for the belt pulleys is mounted on the drilling head. A switch is integrated in the protective cover which monitors that the cover is closed.

INFORMATION

YOU CANNOT START THE MACHINE IF THE PROTECTIVE COVER IS NOT CLOSED.

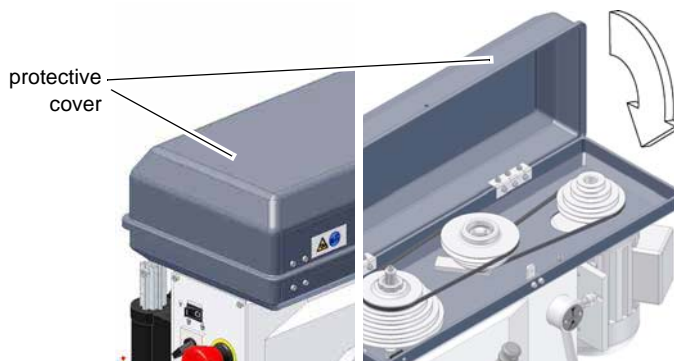

Fig.1-3: Protective cover



1.10.2 Drill chuck guard

Adjust the drill chuck guard to the correct height before you start working.

To do so, detach the clamping screw, adjust the required height and retighten the clamping screw.

A switch is integrated in the fixture of the drill chuck guard which monitors that the cover is closed.

INFORMATION

YOU CANNOT START THE MACHINE IF THE DRILL CHUCK GUARD IS NOT CLOSED.

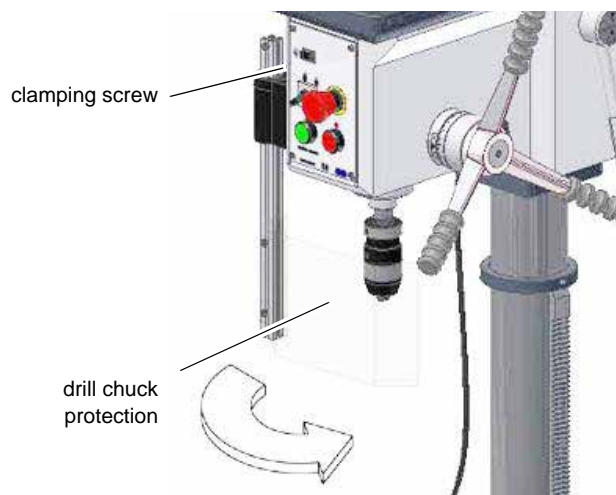

Fig.1-4: Drill chuck guard



1.11 Personal protective equipment

For certain work, personal protective equipments is required. Such as:

- Safety helmet,
- Safety glasses or face guard,
- Protective gloves,
- Safety shoes with steel toe caps,
- Ear protection.

Before starting work, make sure that the prescribed personal protective equipment is available at the workplace.

CAUTION!

Dirty or eventually contaminated personal protective equipments might cause disease.

Clean your personal protective equipment

- after each use,
- regularly, at least once a week.



Personal protective equipment

Protect your face and your eyes: Wear a safety helmet with a face guard for every work, especially for the kind of work where your face and eyes are exposed to hazards.



Use protective gloves when lifting or handling pieces with sharp edges.



Wear safety shoes when fitting, dismantling or transporting heavy components.



1.12 Safety during operation

In the description of work with and on the bench drill and upright drill we highlight the dangers specific to that work.

WARNING!

Before activating the bench drill and upright drill, double-check that

- **staff will not be endangered,**
- **no damage is caused to equipment.**



Avoid unsafe working practice:

- Make sure that your work does not endanger anyone.
- The instructions of this manual must be observed strictly during assembly, operation, maintenance and repair.
- Do not work on the bench drill and upright drill if your concentration is reduced, for example, because you are taking medication.
- Observe the regulations for the prevention of accidents issued by your association for the prevention of accidents and safety in the workplace or other inspection authorities.
- Inform the inspector of any danger or failure.
- Stay at the machine until all rotating parts have come to a halt.
- Use the prescribed personal protective equipment. Make sure to wear a well-fitting work suit and a hairnet, if necessary.
- Do not use protective gloves when drilling.

1.13 Safety during maintenance

Inform the operating staff on time of any repair and maintenance work.

Report all safety-relevant changes or performance details of the bench drill and upright drill. Document all changes, have the operating manual changed accordingly and train the machine operators.

1.13.1 Switching-off and securing the bench drill and upright drill

Turn the bench drill and upright drill off using the main switch and use a padlock to prevent the switch from being turned on without authorization or by accident. Keep the key in a safe place.



All machine components and hazardous voltages are disconnected. Only the points marked with this pictogram are not included.



1.14 Use of lifting equipments

WARNING!

Use of unstable lifting and load-suspension gear that might break under load can cause very serious injuries or even death.



Check the lifting and load-suspension gear on

- sufficient load capacity,
- perfect condition.

Observe the regulations for the prevention of accidents issued by your association for the prevention of occupational accidents and safety in the workplace or other inspection authorities.

Fasten the loads properly. Do not walk under lifted loads!

1.14.1 Mechanical maintenance work

Remove all protection and safety devices before starting maintenance work and re-install them once the work has been completed, such as:

- Covers,
- Safety indications and warning signs,
- Earth (ground) cables.

If you remove protection or safety devices, refit them immediately after completing the work. Check if they are working properly!

1.15 Accident report

Inform your superiors and C.H.HANSON immediately in case of accidents, possible sources of danger and any action which almost lead to an accident "Near misses".

"Near misses" may have many possible causes.

The sooner they are notified, the faster these causes can be eliminated.

1.16 Electrical

Have the machine and / or the electrical equipment checked regularly, at least every six months.

Eliminate immediately all defects such as loose connections, defective wires, etc.

A second person must be present during work on live components, to disconnect the power in case of an emergency.

Disconnect the bench drill and upright drill immediately if there is a malfunction in the power supply!

☞ "Maintenance" on page 49

2 Technical Data

The following data which give dimensions and weight are the manufacturer's authorized machine data

2.1 Power connection	B24H	B28HB B28H
Motor input capacity	1HP, 115V, 60HZ, 1Ph	1HP, 115V, 60HZ, 1Ph
		B28HV
		2HP, 230V, 60HZ, 1Ph

2.2 Drilling capacity	B24H	B28HB B28H B28HV
Drilling capacity in steel	20mm (0.787")	28mm (1.102")
Throat	165mm (6.496")	200mm (7.874")
Spindle travel lifting	85mm (3.346")	105mm (4.134")

2.3 Spindle	B24H	B28HB B28H B28HV
Spindle taper	2 MT	3 MT

2.4 Drilling machine table	B24H	B28HB B28H B28HV
Dimension of the table length x width of the working surface	280mm (11.02") x 300mm (11.81")	340mm (13.39") x 360mm (14.17")
T-slot dimension	14mm (0.551")	
Maximum distance spindle - table	515mm (20.28")	858mm (33.78")
Maximum distance spindle - base	681mm (26.81")	B28HV
		1274mm (50.16")
		B28HB
Working surface base length x width of the working surface	280mm (11.02") x 260mm (10.24")	B28HB B28H
		360mm (12.60") x 360mm (12.60")
		B28HV
		370mm (14.57") x 360mm (12.60")

2.5 Required space	B24H	B28HB B28H B28HV
Height	1850mm (72.84")	2000 (78.74")
		B28HB
		1850mm (72.84")
Depth	1700mm (66.93")	1800mm (70.87")
Width	1500mm (59.06")	1600mm (62.99")

2.6 Speeds	B24H	B28HB B28H
Spindle speeds [rpm]	420 - 4000	262 - 4075
Number of stages	7	16
	B28HV	
Spindle speeds [rpm]	35 - 4000	
Number of stages	12	

2.7 Environmental conditions	B24H	B28HB B28H B28HV
Temperature	41 - 95 °F	
Rel. humidity	25 - 80 %	

2.8 Operating material	B24H	B28HB B28H B28HV
Toothed rack	commercial lubricating grease	
Column	acid-free lubricating oil, e.g. machine oil, motor oil	

2.9 Emissions

The noise level emission of the bench drill and upright drill is below 76 dB(A). If the bench drill and upright drill is installed in an area where various machines are in operation, the acoustic influence (immission) on the operator of the bench drill and upright drill may exceed 85 dB(A).

INFORMATION

This numeric value had been measured on a new machine under conventional operating conditions. Depending on the age or wear of the machine, the noise behavior of the machine might change.

Furthermore, the extent of the noise emission is also depending on manufacturing influence factors, such as speed, material and clamping conditions.



INFORMATION

The mentioned numerical value is an emission level and not necessarily a safe working level.

Unless the degree of noise emission and the degree of noise disturbance are depending on one another it is not possible to use it in order to reliably determine if it is necessary to take further preventive measures or not.

The following factors influence the actual degree of the noise disturbance of the operator:

- Characteristics of the working chamber, e.g. size or damping behavior,



- Other noise sources, e.g. the number of machines,
- Other processes proceeding nearby and the period during which the operator is exposed to the noise.

Furthermore, the admissible pollution level may be different from one country to another due to the national regulations.

This information regarding the noise emission should allow the operator of the machine to perform a better evaluation of the endangerments and risks.

CAUTION!

The machine operator has to wear an appropriate ear protection depending on the overall stress caused by noise and on the basic limit values.

We generally recommend using a sound and ear protection.



2.10 Dimensions B24H

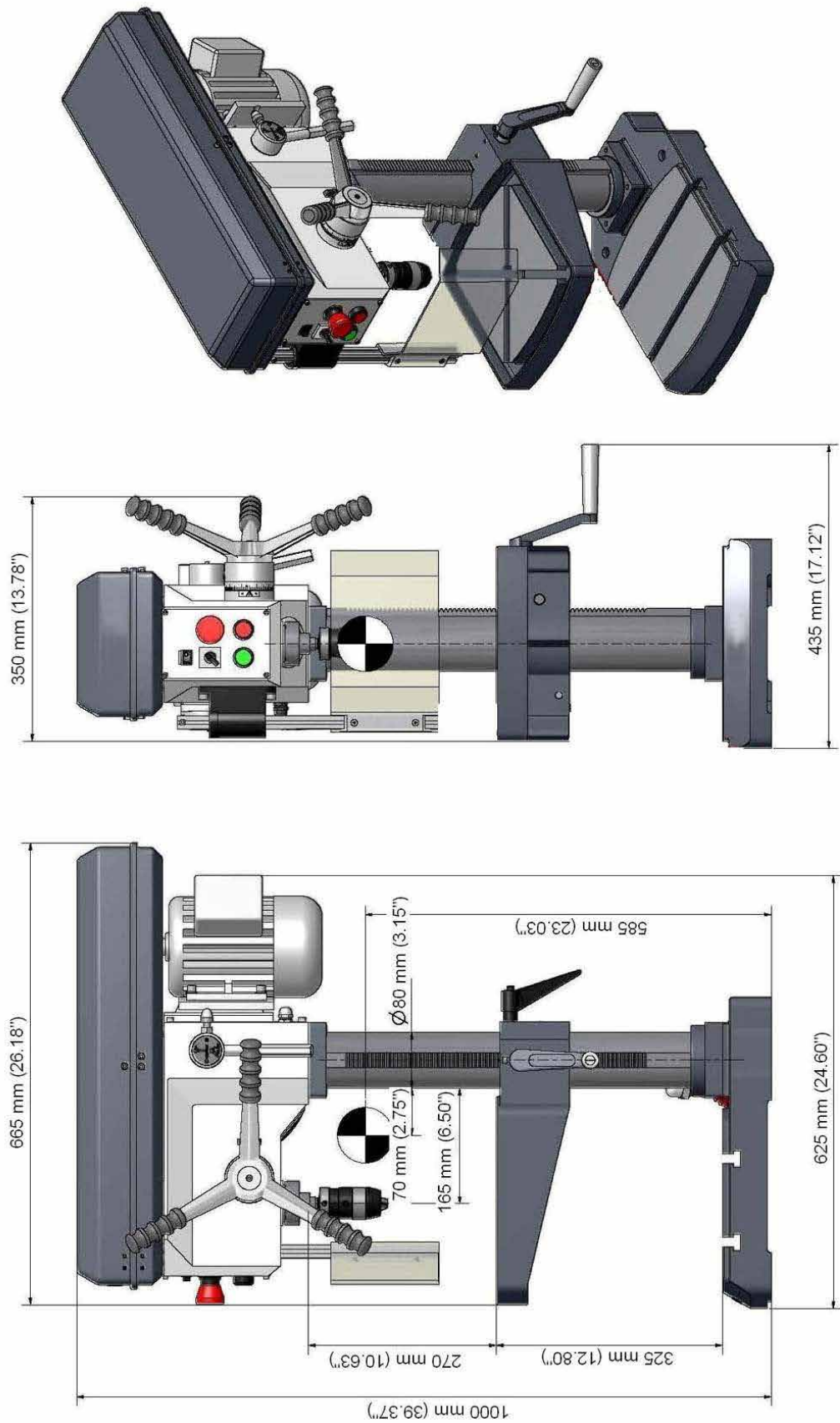

Centre of gravity
Total weight: 84 kg (185 lbs)



Fig.2-1: Dimensions B24H

2.11 Dimensions B28HB

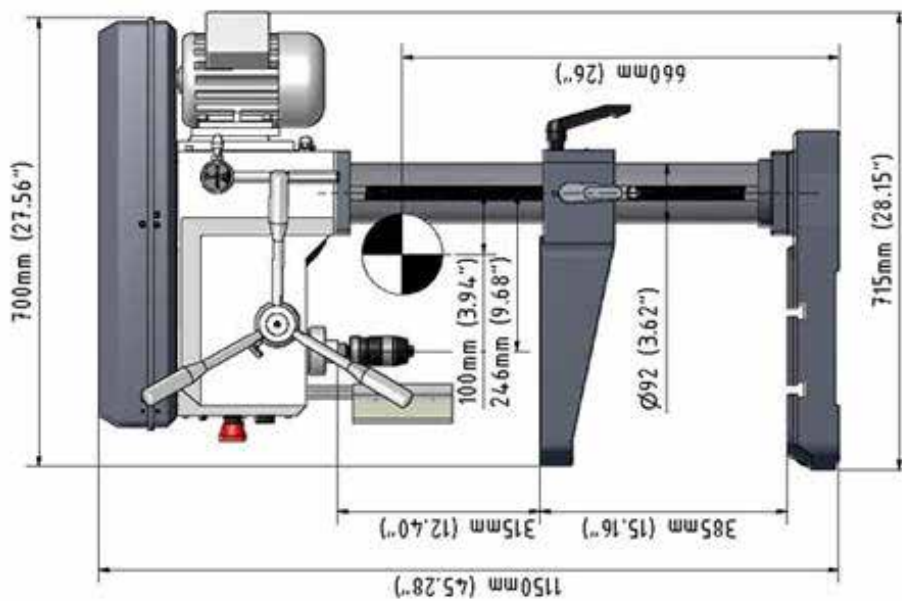
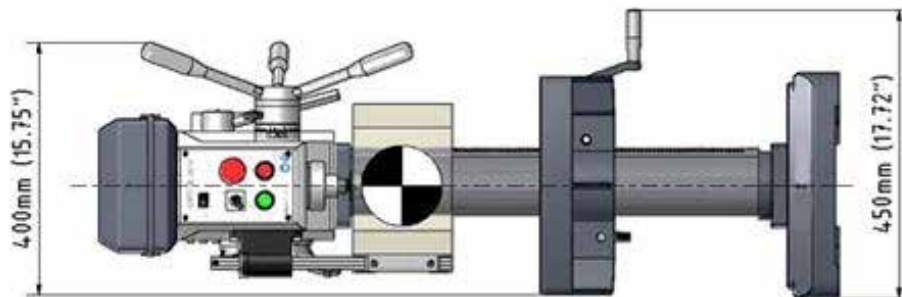
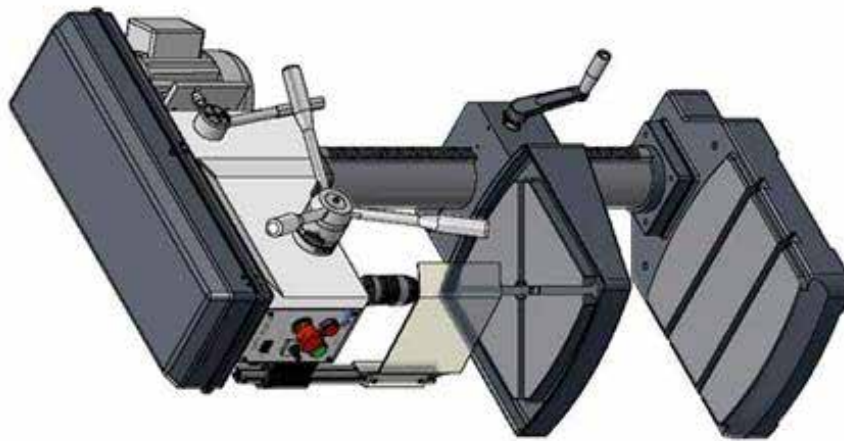
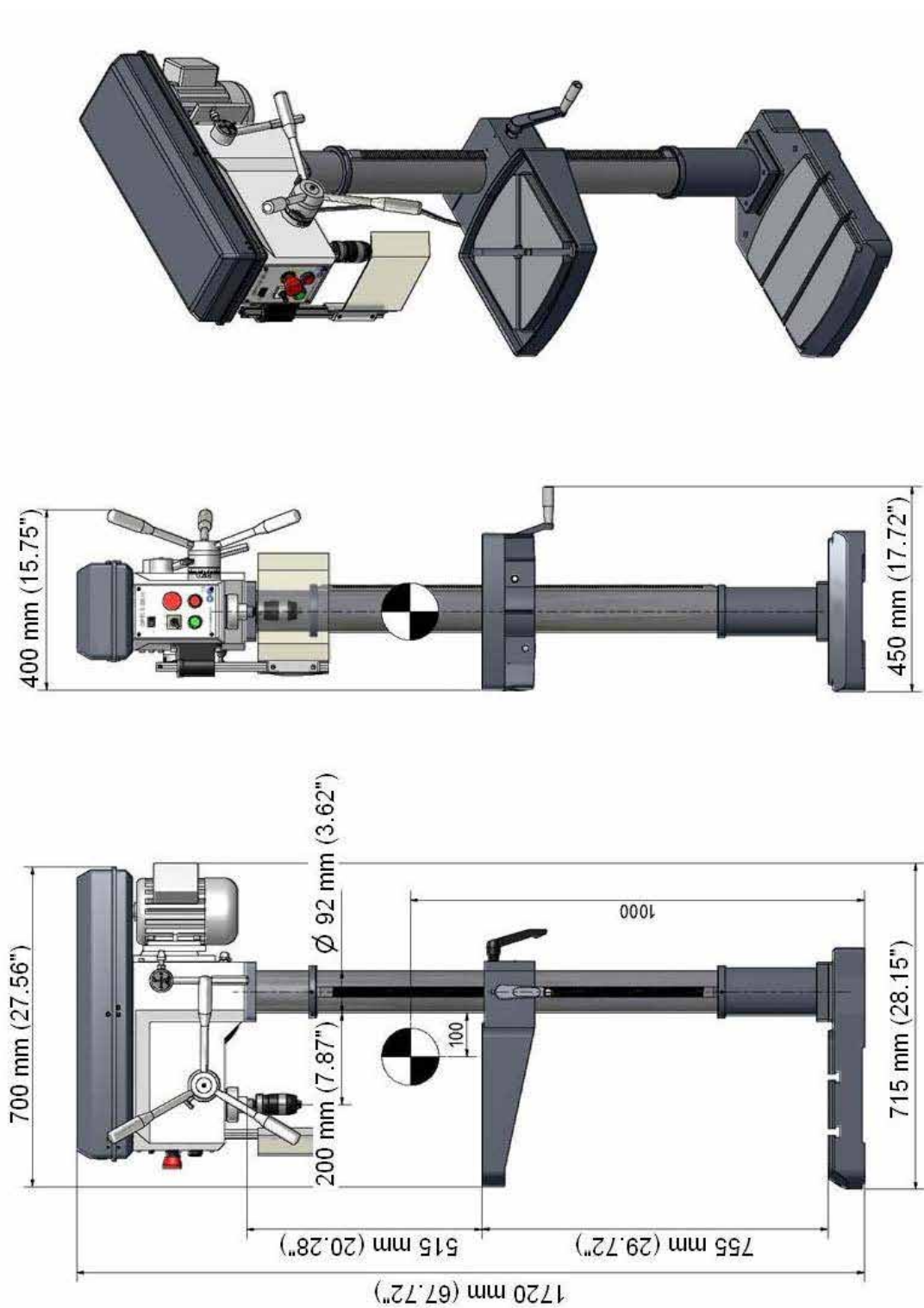

Fig.2-2: Dimensions B24HB

2.12 Dimensions B28H



Centre of gravity
Total weight: 140 kg (308 l)



Fig.2-3: Dimensions B28H

2.13 Dimensions B28HV

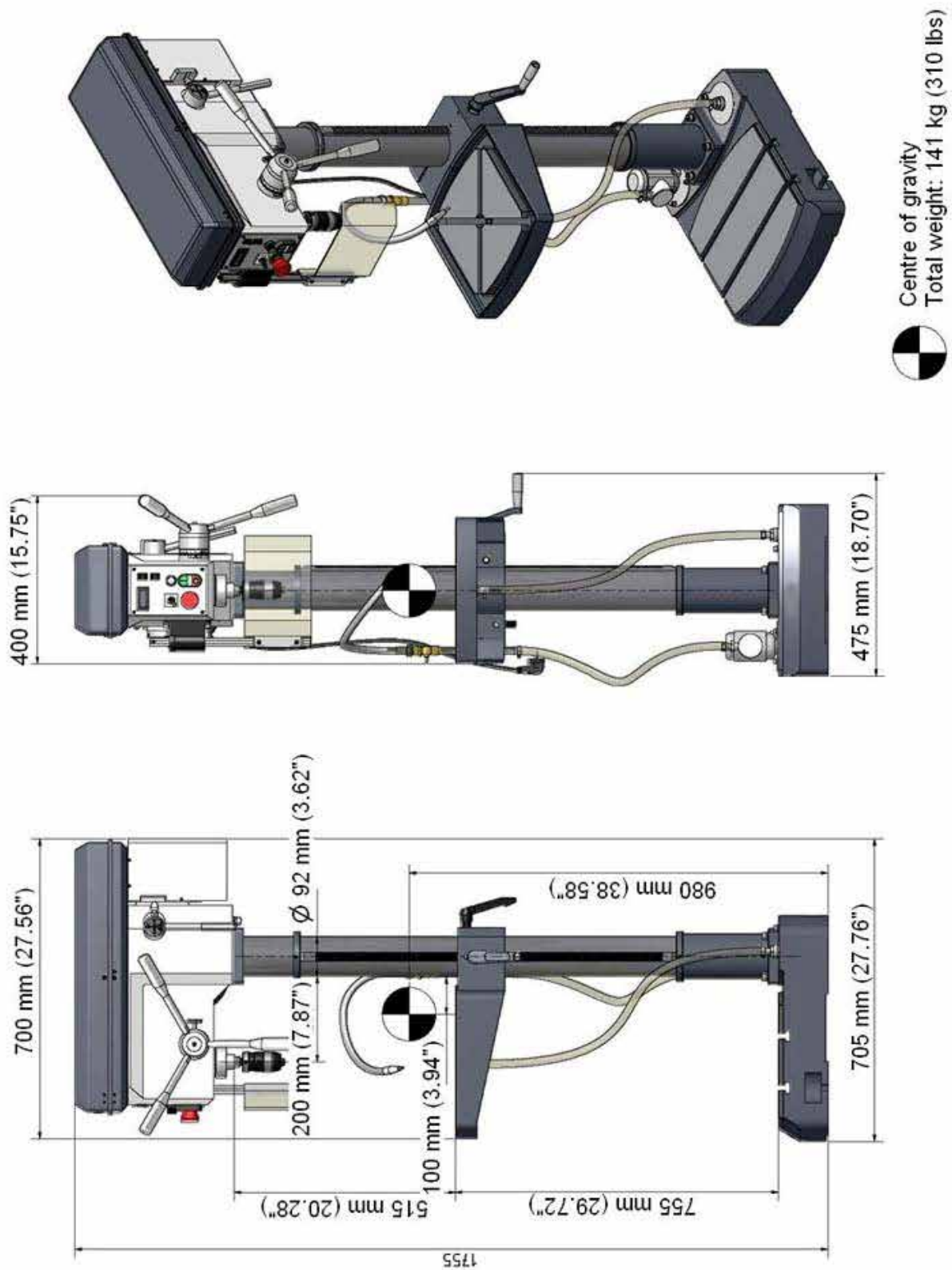

Fig.2-4: Dimensions B28HV

3 Assembly

3.1 Scope of delivery

Please check immediately that nothing had been damaged during transportation and that all components are complete. Compare the delivery volume to the attached packing list.

3.2 Transport

- Center of gravity
- Attachment positions (marking the positions for the attachment position gear)
- Prescribed transport position (marking the top side)
- Means of transportation to be used
- Weights

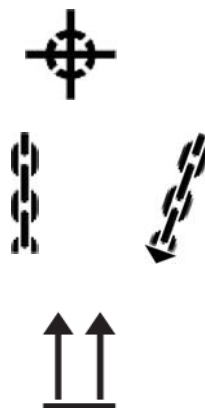

WARNING!

Machine parts which fall off forklift trucks or other transport vehicles could cause very serious or even fatal injuries. Follow the instructions and information on the box.



WARNING!

Use of unstable lifting and load suspension gear that breaks under load can cause very serious injuries or even death.

Check that the lifting and load suspension gear has sufficient load capacity and is in perfect condition. Observe the rules for preventing accidents issued by your association for the prevention of occupational accidents and safety in the workplace or other inspection authorities.



Hold the loads properly. Never walk under suspended loads!

3.3 Storage

ATTENTION!

Improper storage may cause important parts to be damaged or destroyed. Store packed or unpacked parts only under the following ambient conditions. Please follow the instructions and indications on the transportation box:



- Fragile goods (goods require careful handling)



- Protect against humidity and humid environments
☞ "Environmental conditions" on page 17.



- Prescribed position of the packaging box (marking the top side – arrows pointing upward)



- Maximum stacking height

Example: non-stackable – do not pile any further packaging boxes on top of the first packaging box



Consult C.H.HANSON if the bench drill and upright drill and accessories have to be stored for a period of over three months or under different external conditions than those given here ☞ "Information" on page 5.

3.4 Installation and assembly

3.4.1 Site requirements

Organize the working space around the bench drill and upright drill according to the local safety regulations.

INFORMATION

In order to provide for good functionality and high machining accuracy as well as long durability of the machine the site should fulfill certain criteria.



Observe the following items:

- The device must only be installed and operated in dry ventilated places.
- Avoid places nearby machines generating chips or dust.
- The site has to be vibration-free, i.e. at a distance from presses, planing machines, etc.
- The substructure has to be appropriate for bench drill and upright drill. Also make sure that the load bearing capacity and the evenness of the floor are appropriate.
- The substructure has to be prepared in a way that possibly used coolant cannot penetrate into the ground.
- Protruding parts such as stops, handles, etc. need to be secured by measures provided by the customer if necessary in order to avoid dangers for persons.
- Provide sufficient space for assembly and operating staff as well as for material transport.
- Also allow for accessibility for setting and maintenance works.
- Make sure that the main power for the drilling machine is freely accessible.
- Provide for sufficient illumination (minimum value: 47 Lumens/ft², measured at the tool tip). In case of little intensity of illumination provide for additional illumination i.e. by a separate workplace illuminator.

INFORMATION

The main power of the bench drill and upright drill has to be freely accessible.



3.4.2 Assembly

WARNING!

Danger of crushing when grouping, assembling and mounting the machine components.



Assembly of base and column

INFORMATION

For the mounting of bench drill and upright drill you need a wrench and the hexagon screws which are included in the delivery volume.



→ Put the base on the floor and fix the column to the stand. Use the hexagon screws to fix it.

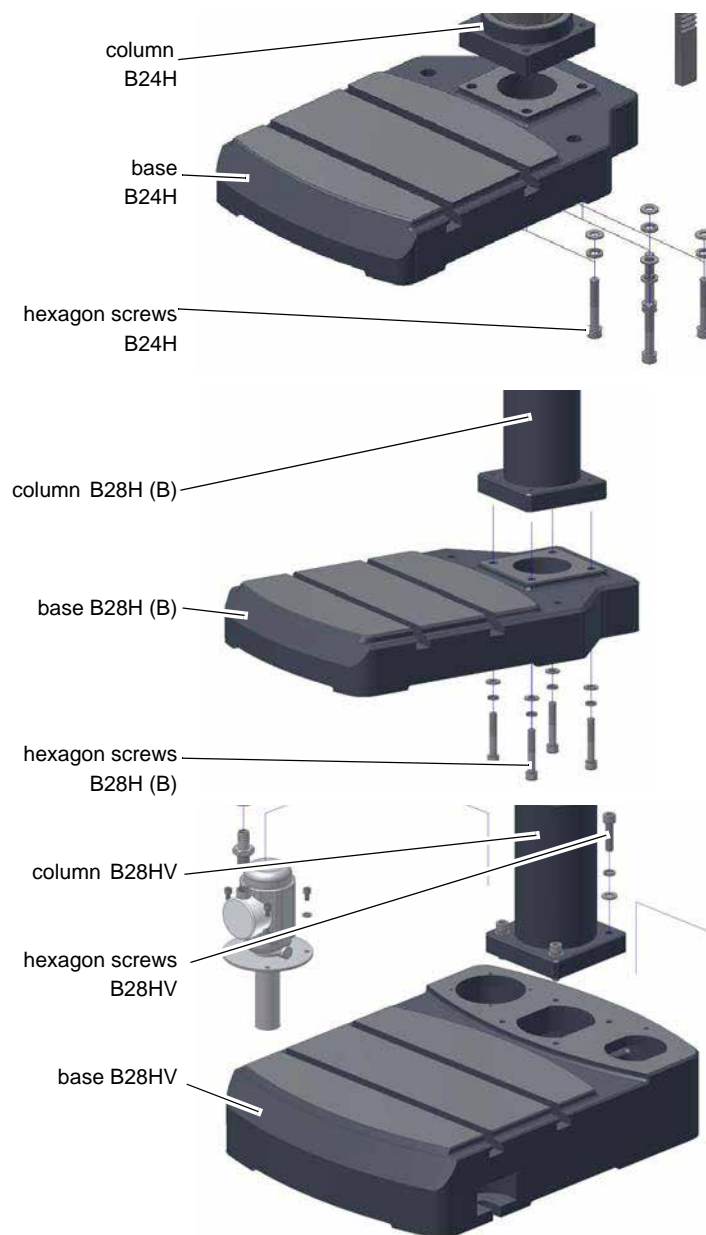

Fig.3-1: Assembly column

3.4.3 Assembly of the drilling machine table B24H (B28H B)

- Insert the toothed rack in the drilling table.
- Adjust the toothed rack within the drilling machine table in a way that the teeth of the toothed rack cam into the spiral wheel of the support for the drilling machine table.
- Insert the drilling table with the toothed rack on the column.



Fig.3-2: Assembly drilling table B24H (Vario)

3.4.4 Assembly of the drilling machine table B28H (Vario)

- Insert the toothed rack in the drilling table.
- Adjust the toothed rack within the drilling machine table in a way that the teeth of the toothed rack cam into the spiral wheel of the support for the drilling machine table.
- Insert the drilling with the toothed rack on the column.

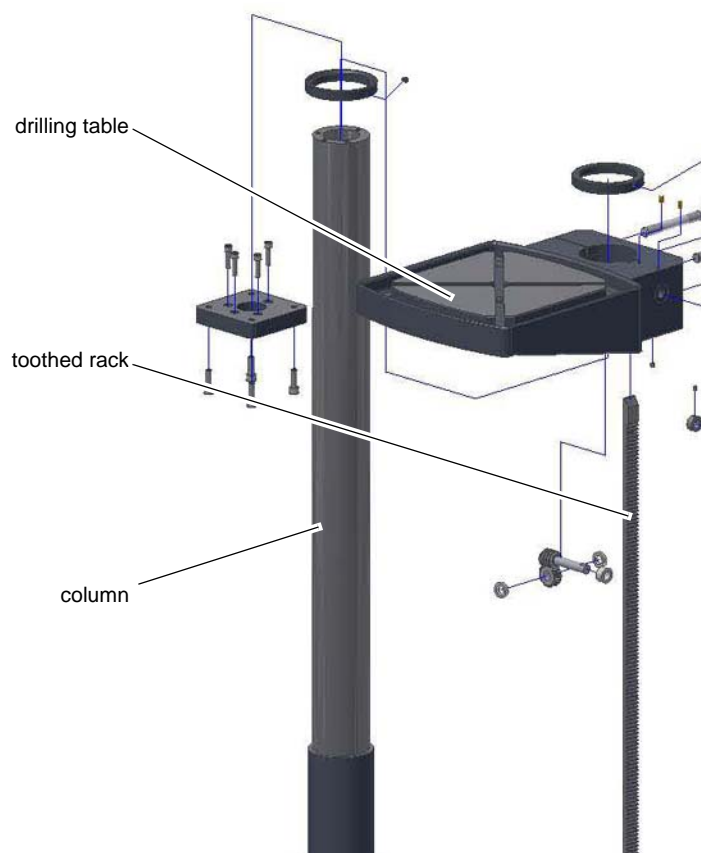

Fig.3-3: Assembly drilling table B28H (Vario)

- ➔ Mount cooling equipment.
- ➔ Mount all cooling agent hoses and fasten you these with the hose clamps.

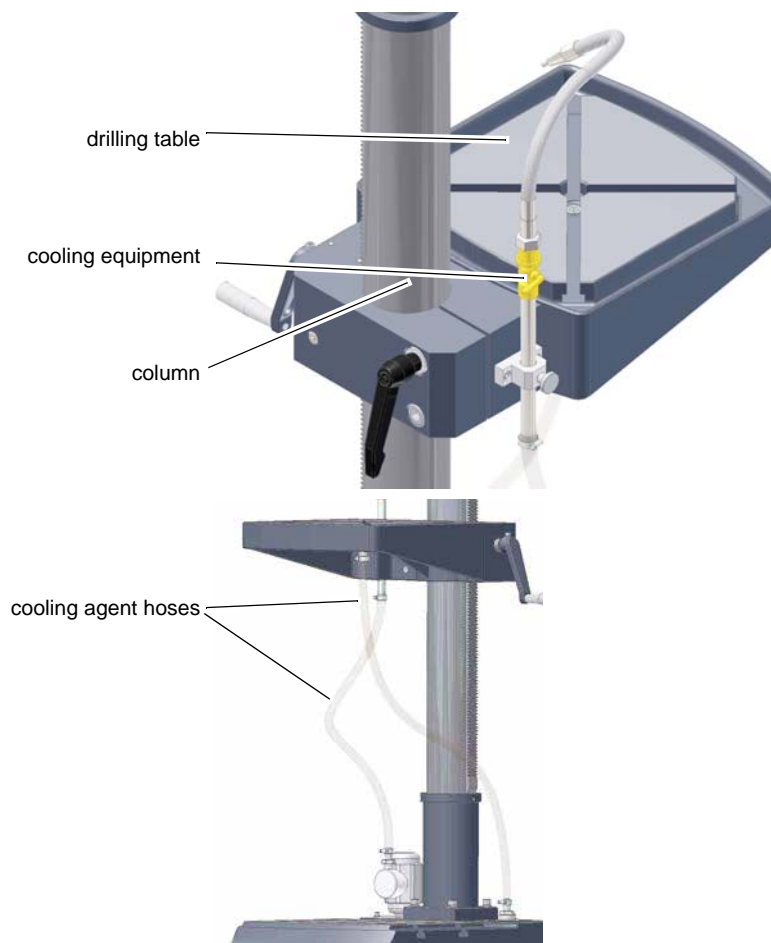

Fig.3-4: Assembly drilling table B28H (Vario)

INFORMATION

The longer side of the toothed rack without tothing must be upside.

- ➔ Insert the guide ring on to the column and the toothed rack.
- ➔ Fix the guide ring and the locking screw.

Make sure that you can still easily turn the drilling table round the column.

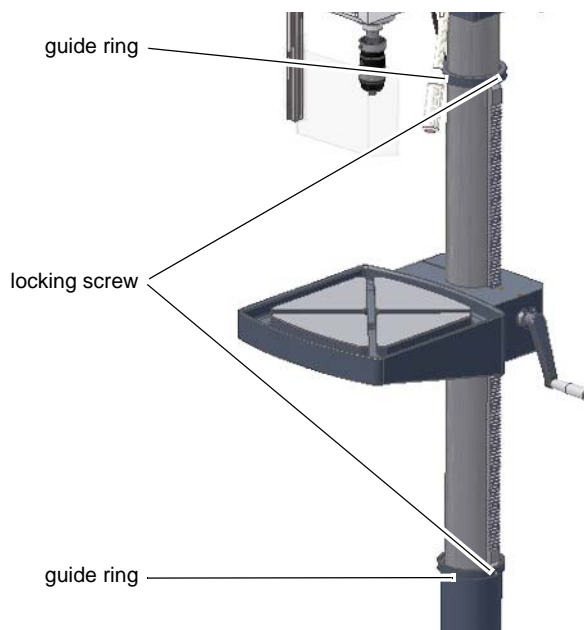

Fig.3-5: Assembly guide ring B28H (Vario)



- Mount the crank handle to the height adjustment arm of the drilling table.
- Tighten the crank handle securely.

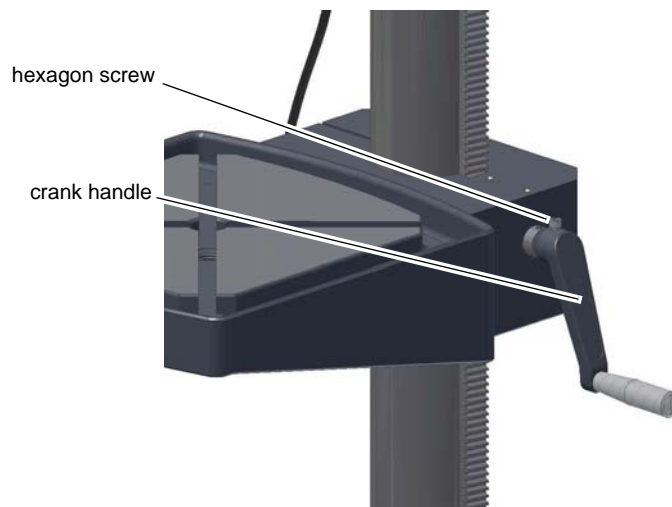

Fig.3-6: Mounting of crank handle

Mounting the boring head

- Put the distance plate on the column.
- Fix the distance plate with the cap screws on the column.
- Put the boring head on the distance plate and turn it until it aligns with the base.
- Fix the boring head with the cap screws on the distance plate.

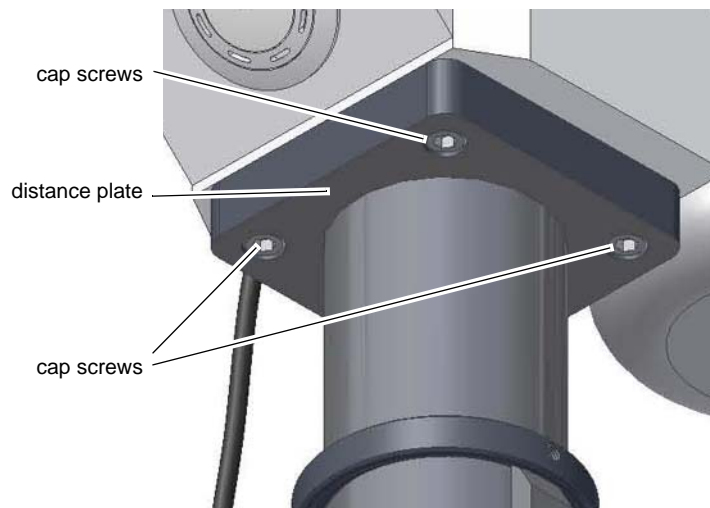

Fig.3-7: Assembly boring head

3.5 Installation

- Check the horizontal orientation of the base of the bench drill and upright drill with a spirit level.
- Check that the foundation has sufficient floor-load capacity and rigidity.
- Position the bench drill and upright drill on the intended foundation.
- Attach the bench drill and upright drill using the provided recesses in the machine base.

WARNING!

The quality of the foundation and the mounting method of the machine base to the foundation has to assimilate the loads of the machine. The foundation needs to be even. Please check the horizontal alignment of the foundation of the machine with a spirit level.



3.5.1 Mounting

In order to provide for the necessary stability of the drilling machine it is necessary to firmly bolt the base of the machine to the foundation. We recommend you to use compound anchor cartridges or heavy duty anchors.

➔ Mount the drilling machine to the foundation using the provided through-holes on the base.

The through-holes are marked with arrows on the machine base.

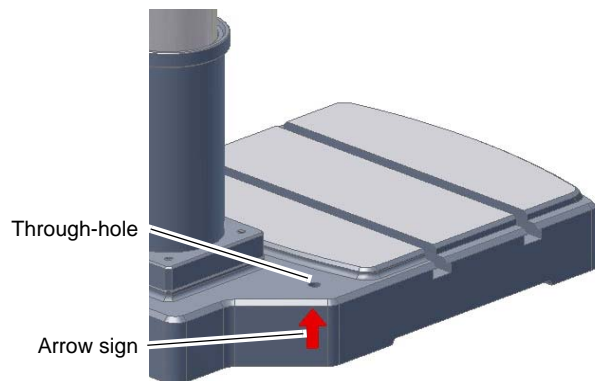

Fig.3-8: Labeling of the anchorage point on drilling machine B24H, B28H (B)

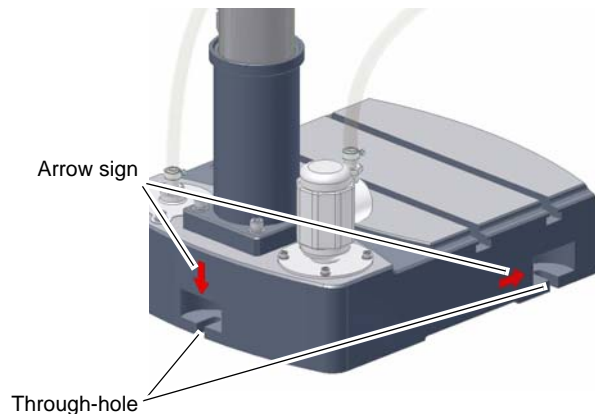

Fig.3-9: Labeling of the anchorage point on drilling machine B28H (Vario)

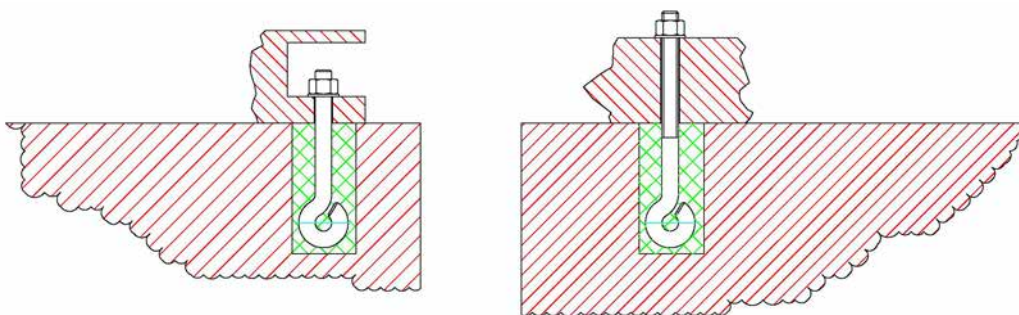

Fig.3-10: Bottom attachment

ATTENTION!

Tighten the anchor bolt nuts on the bench drill and upright drill only until it is firmly secured and can neither move during operation nor be turned over.

If the anchor bolt nuts are too tight and the foundation is uneven, the base of the bench drill and upright drill may break.



3.5.2 Installation drawings

B24H

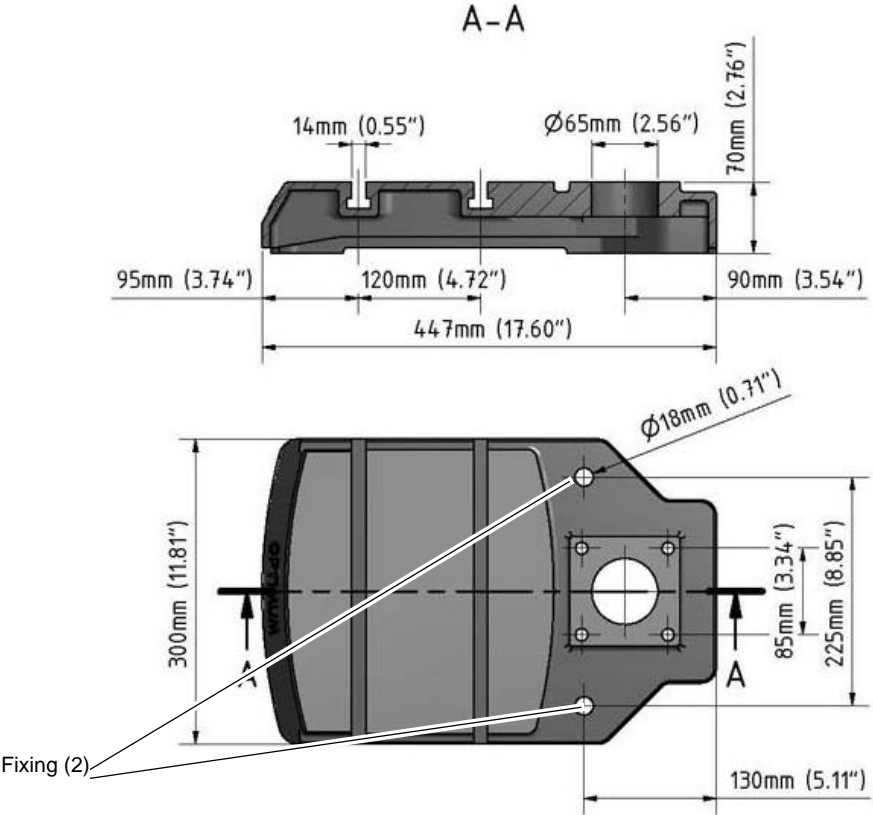

Fig.3-11: B24H

B28H (B)

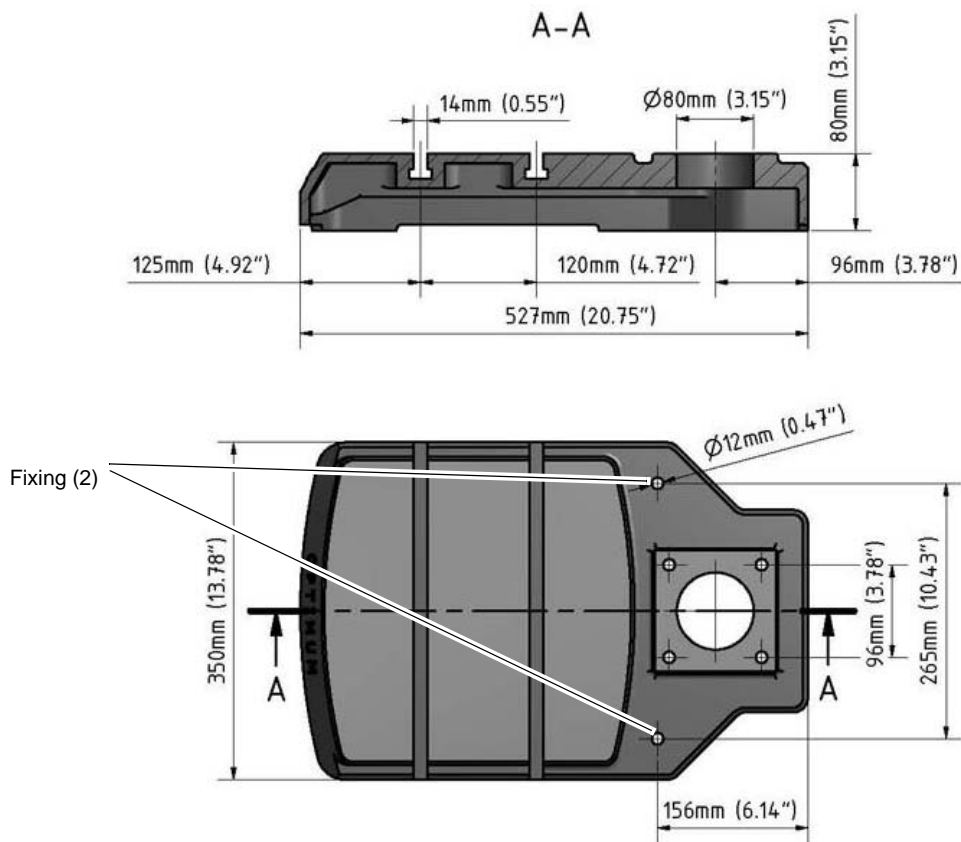

Fig.3-12: B28H

B28H (Vario)

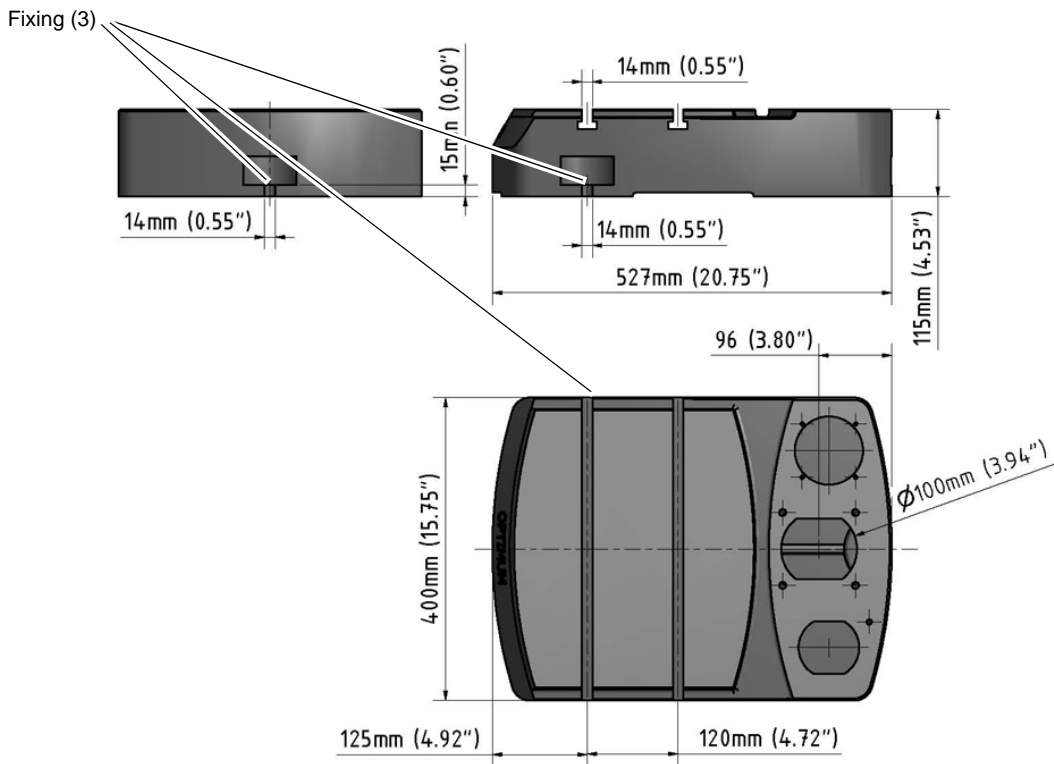

Fig.3-13: B28H (Vario)

3.6 First use

WARNING!

Risk by using improper workpiece clamping materials or by operating the machine with inadmissible speed.

Only use the clamping materials (e.g. drill chuck) which had been delivered together with the machine or as optional equipment offered by company.

Use the working clamping materials only in the provided admissible speed range.

Workpiece clamping materials must only be modified according to the recommendations of company or of the clamping material manufacturer.



WARNING!

Staff and equipment may be endangered if the bench drill and upright drill is first used by unexpert staff.

We do not take responsibility for damage caused by incorrect commissioning.

☞ "Qualification of employees" on page 9



Power supply

→ Connect the electrical feeds.

→ Check the fuse protection (fuse) of your electrical supply according to the technical specifications for the total connected load of the bench drill and upright drill.

ATTENTION!

For 230V machines: Imperatively make sure that all 3 phases (L1, L2, L3) are connected correctly.

Most of the defects on motors are resulting from wrong connections. For instance, if a motor phase is not correctly clamped or connected to the neutral conductor (N).

This may cause:

- That the motor is becoming hot very rapidly
- Increased motor noises.
- The motor has no power.



ATTENTION!

Make sure that the direction of rotation of the drive motor is correct. If the rotational direction switch is switched to the position to perform clockwise rotations (R) the drill spindle needs to rotate clockwise. If necessary, exchange two phase connections.

If your connector plug is equipped with a phase inverter, this is done by turning it by 180°.

If the machine is wrongly connected the warranty will become null and void.



4 Operation

4.1 Safety

Use the machine only under the following conditions:

- The machine is in proper working order.
- The machine is used as prescribed.
- The instruction manual has been followed.
- All safety devices are installed and activated.

All malfunctions should be eliminated immediately. Stop the machine immediately at an event of any malfunction in operation and make sure it cannot be started up accidentally or without authorization.



Notify the person responsible immediately of any modification.

☞ "Safety during operation" on page 14

4.2 Control and indicating elements

4.2.1 Drilling machine B24H | B28 HB

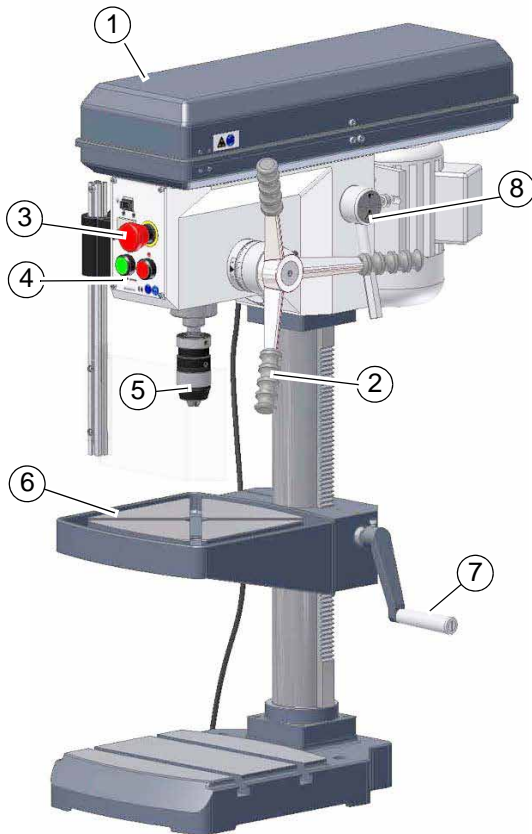

Img.4-1: B24H | B28HB

Pos.	Description	Pos.	Description
1	Belt drive with housing	2	Lever for spindle sleeve feed
3	Emergency stop	4	On/Off Control
5	Drill chuck	6	Drilling table
7	Table height adjustment	8	Lever for belt tension

4.2.2 Drilling machine B28H | B28HV

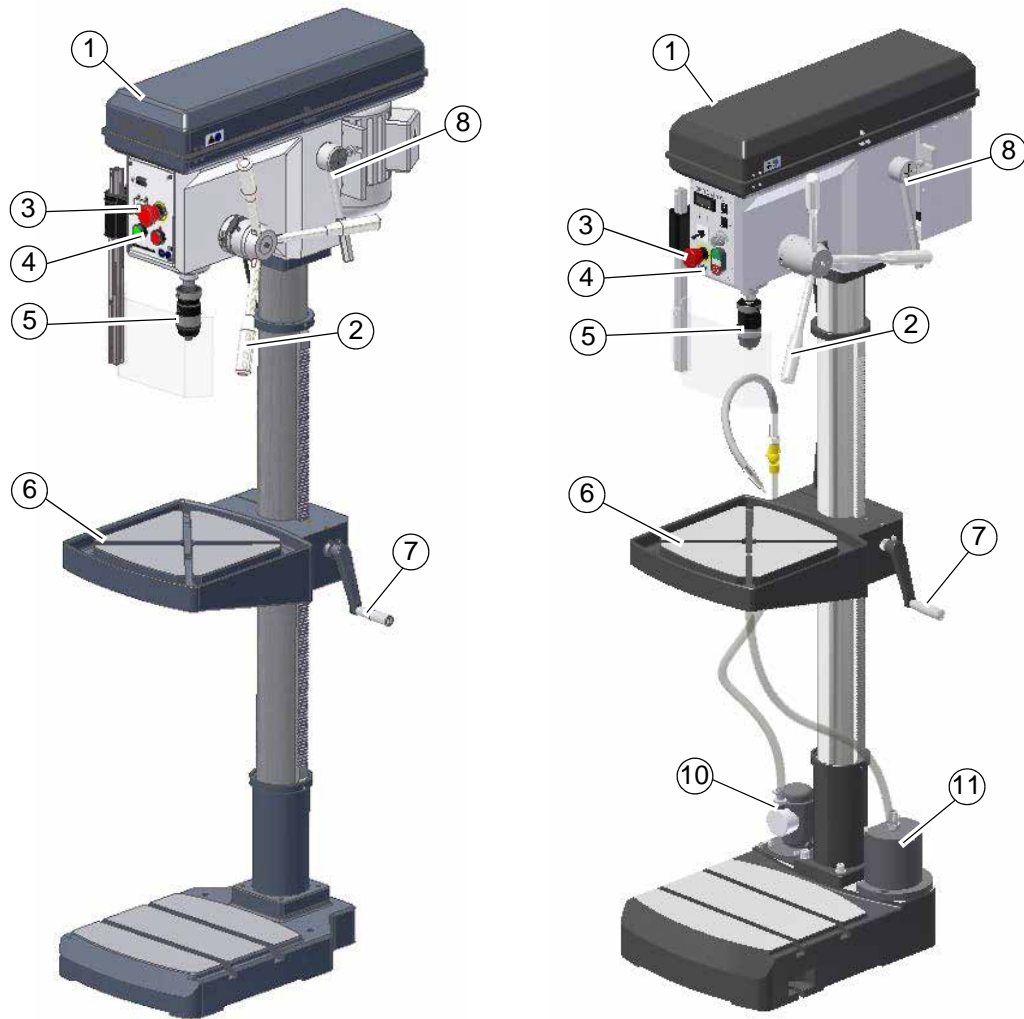

Img.4-2: B28H | B28HV

Pos.	Description	Pos.	Description
1	Belt drive with housing	2	Lever for spindle sleeve feed
3	Emergency stop	4	On/Off Control
5	Drill chuck	6	Drilling table
7	Table height adjustment	8	Lever for belt tension
10	Coolant agent equipment B28HV	11	chip filter B28HV

4.2.3 Control panel B24H

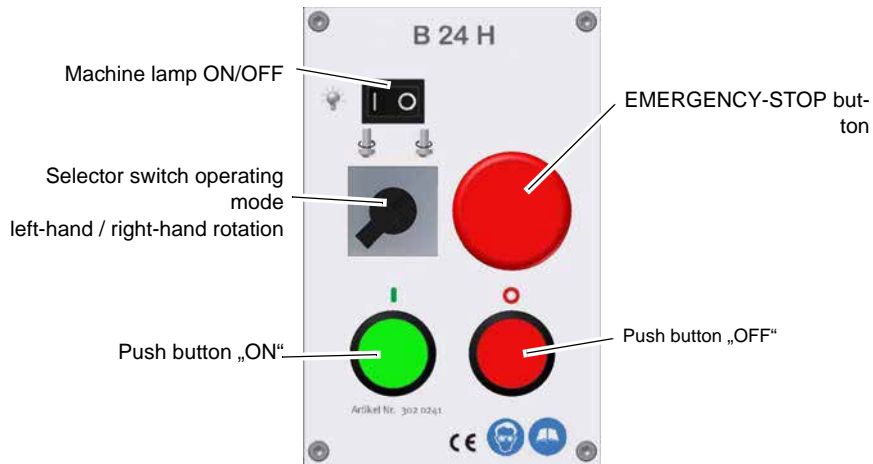

Fig.4-3: Operating element on the control panel B24H

4.2.4 Control panel B28H (Vario), B28HB

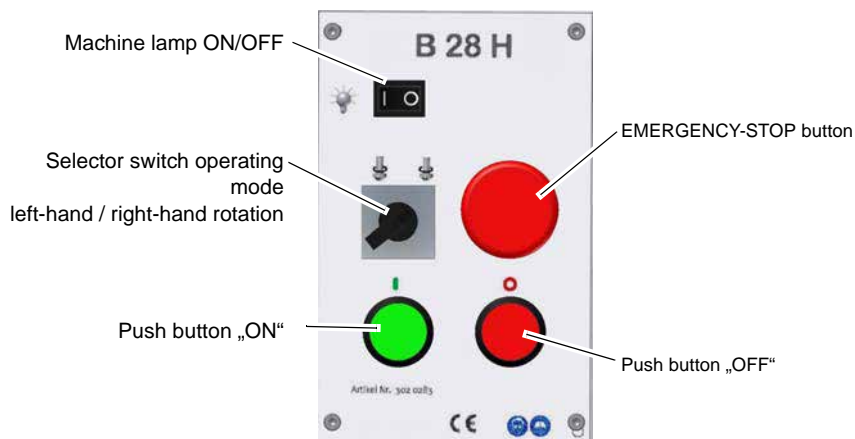

Fig.4-4: Operating element on the control panel B28H | B28HB

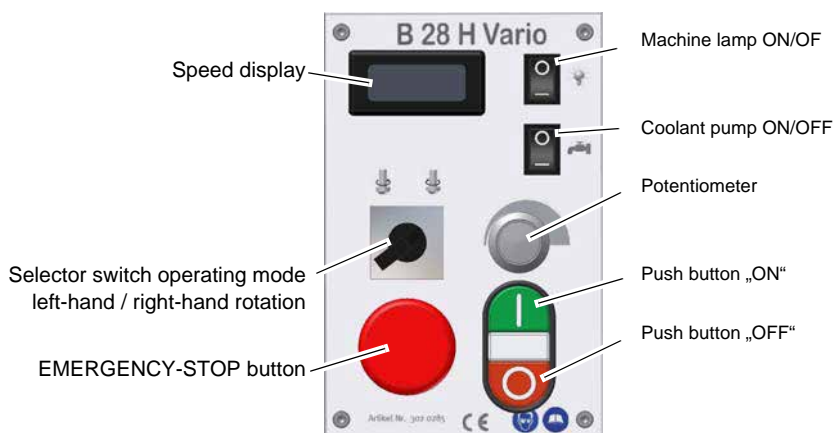

Fig.4-5: Operating element on the control panel B28HV

Switch for the turning direction

Standard operation, selection right-handed or left-handed rotation.

Potentiometer

Speed setting "VARIO"

Push button ON

The push button „ON“ will start up the rotation of the drill spindle.

Push button OFF

The push button „OFF“ switches off the rotation of the drill spindle.

Coolant pump ON / OFF

Switches the coolant pump ON or OFF.

Machine lamp ON / OFF

Switches the coolant pump ON or OFF.

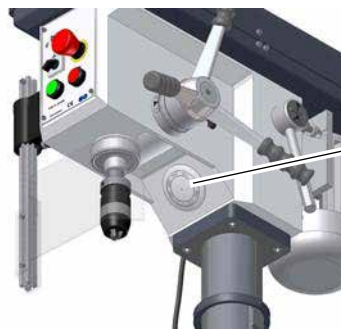

Machine lamp
B24H/ B28H (B) (Vario)

Fig.4-6: Machine lamp B24H | B28H | B28HB | B28HV

Operating control lamp

The operating control lamp on the operating panel has to flash.

Main switch

Interrupts or connects the power supply.



4.3 Turn the machine on B24H / B28H / B28HB

→ Turn the main switch on.



→ Select the turning direction.



→ Actuate the push button „ON“.



4.4 Turn the machine on B28HV

→ Turn the main switch on.



→ Select the turning direction.

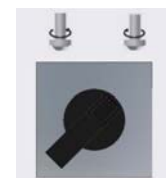

→ Actuate the push button „ON“.



4.5 Turn the machine off B24H / B28H / B28HB

→ Actuate the push button „OFF“.



→ If the machine stands still for a longer period of time, switch off the main switch.



4.6 Turn the machine off B28H Vario

→ Actuate the push button „OFF“.



→ If the machine stands still for a longer period of time, switch off the main switch.



4.7 Speed variation

WARNING!

Danger due to drill chuck or tools flying off at high speed. Make sure not to exceed the maximum speed of the drill chuck when setting the spindle speed.



- Switch off the main switch of the machine.
- Open the protective cover.
- Loosen the clamping lever of the V-belt tension.
- Put the V-belt to the required position.

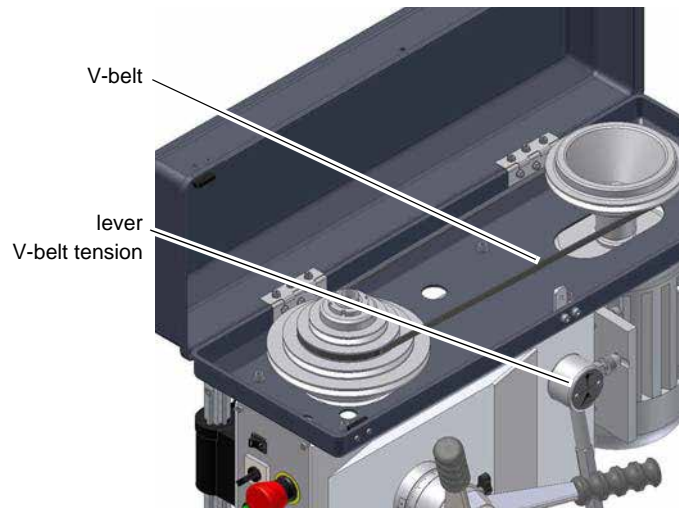

Fig.4-7: Lever for the V-belt tension B24H

- Tension the clamping lever.
- Close the protective cover.

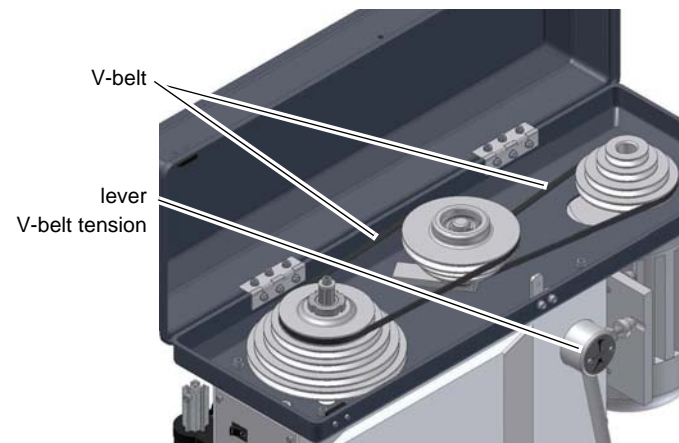

Fig.4-8: Lever for the V-belt tension B28H | B28HB | B28HV

4.7.1 Speed table B24H

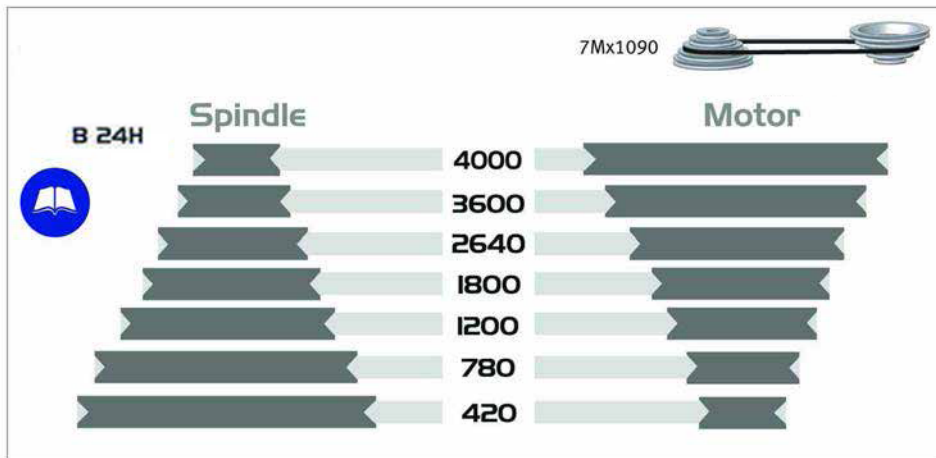

Fig.4-9: Speed table B24H

4.7.2 Speed table B28H - B28HB

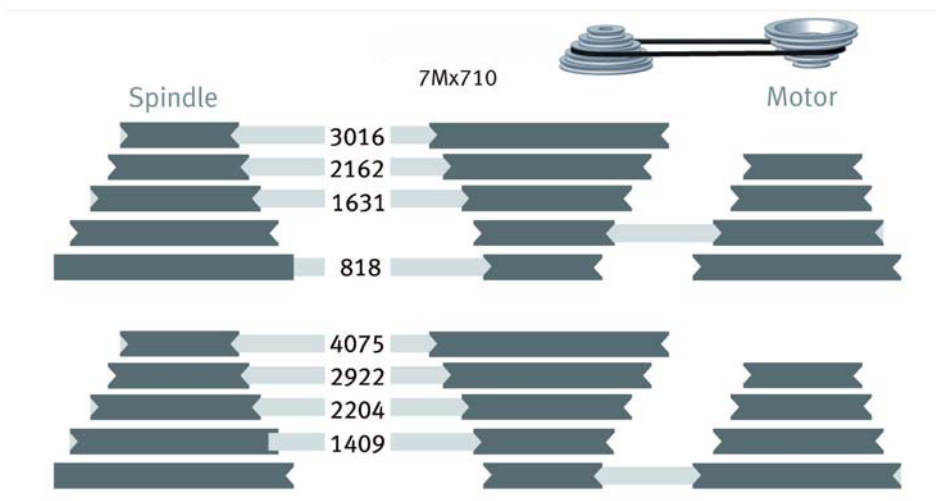

Fig.4-10: Speed table B28H | B28HB

4.7.3 Speed table B28HV

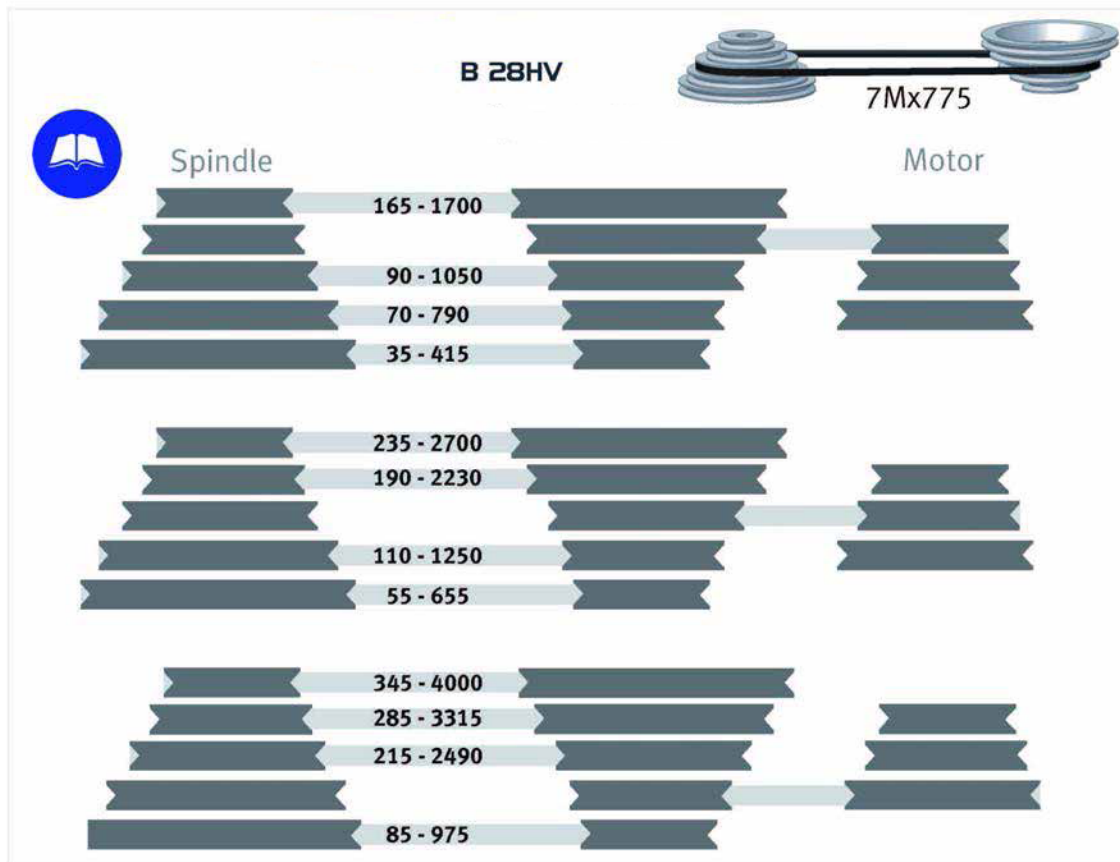

Fig.4-11: Speed table B28HV

4.8 Drill depth stop

When drilling several holes of the same depth, you can use the drill depth stop.

- Loosen the locking screw and turn the graduated collar until the required drilling depth matches with the indicator.
- Re-tighten the locking screw.

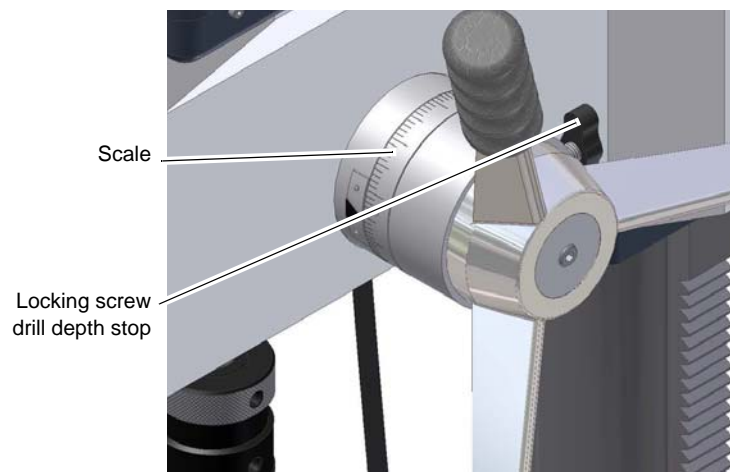

Fig.4-12: drill depth stop

4.9 Removing, mounting of drill chucks and drills

4.9.1 Keyless drill chuck

The drill chuck consists of two parts (No. 1 and No. 2).

- Hold the upper part (No. 1) of the drill chuck. With the lower part (No. 2) of the drill chuck one can firm and/or loose-turn the cheeks of the drill chuck.
- Turn the tool (drill) firmly.

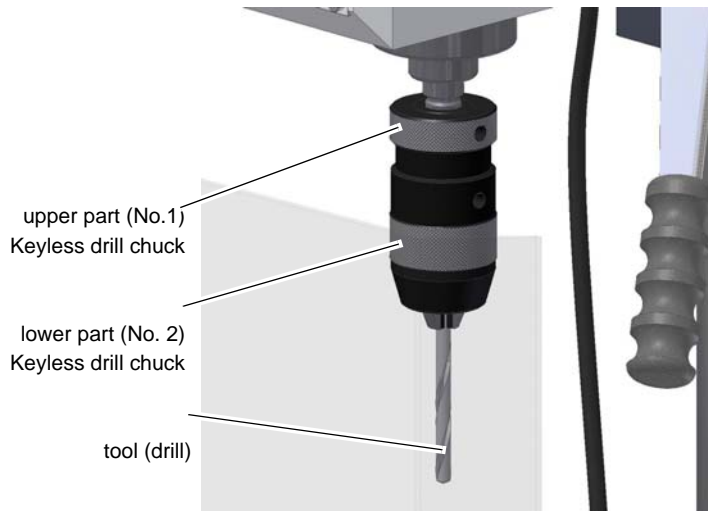

Fig.4-13: drill chuck

ATTENTION!

Make sure that the chucked tool is positioned firmly and correctly.



4.9.2 Removing the drill chuck

The drill chuck and the morse taper are released from the drill spindle by a drill drift.

WARNING!

Remove the drill chuck only when the bench drill and upright drill is disconnected from the electrical power supply.

- Switch off the bench drill and upright drill with the main switch or disconnect the power plug.
- Turn the drill spindle downwards.
- Turn the drill spindle in a way that the openings on the drill quill and on the drill spindle are superimposed.
- Loosen the morse taper of the drill chuck by means of a drill drift.

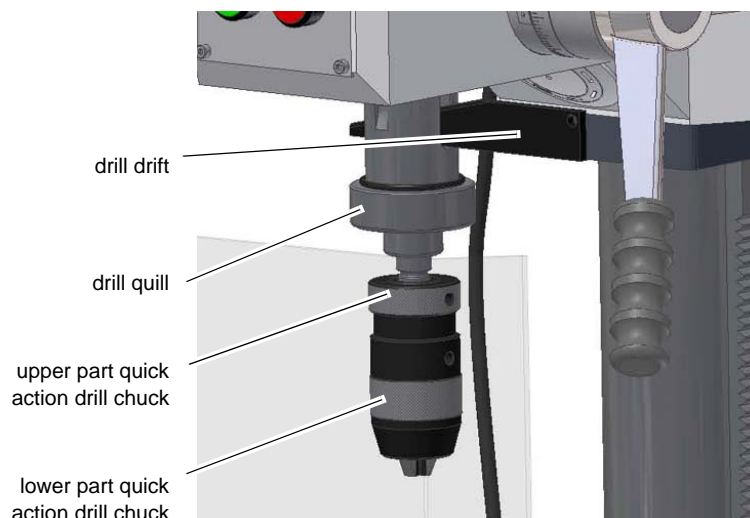

Fig.4-14: Disassembly B24H



4.9.3 Removing the tool or drill chuck with the integrated drill drift on the B28H (B, Vario)

CAUTION!

Hold the tool ② or the drill chuck.

With the below described procedure the taper mandrel is being loosened from the drill spindle. The tool and/or the drill chuck will fall down.

CAUTION!

Do not try to expel the tool when it is in the intermediate position. This might cause damages of the integrated drill drift or of the feed handle.

- Lower the spindle until the two circumscribed lines on the quill are visible.
- Push the locking pin ① inside the quill fully inside. Be sure that the pin is fully engaged inside the quill.
- Raise the spindle upward while holding the chuck.
- The chuck arbor will be pushed out of the spindle.
- Pull out the locking pin ① fully out of the quill.

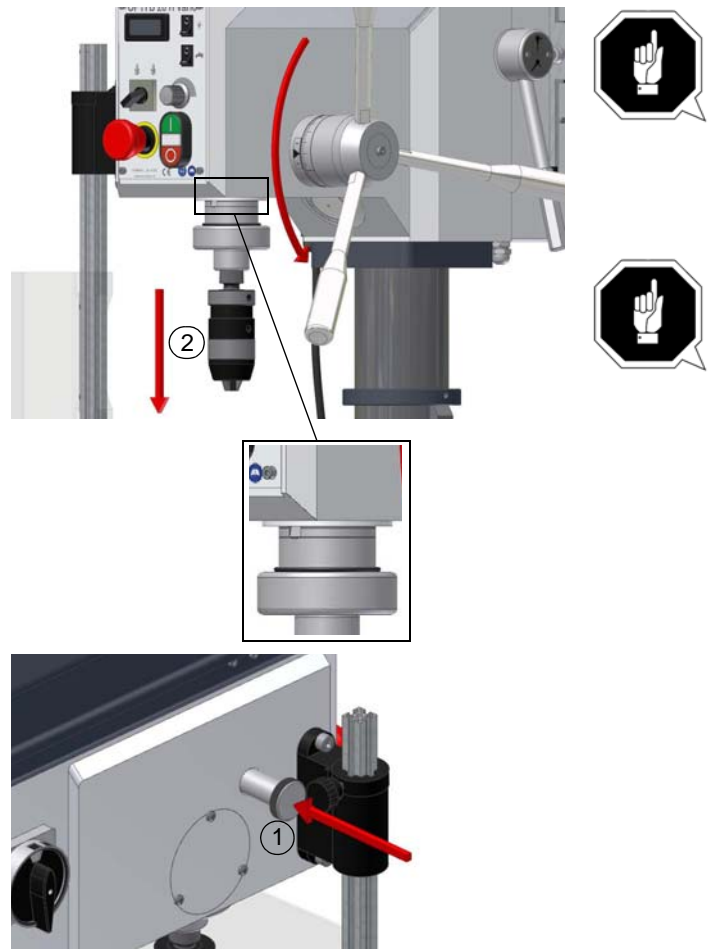

Fig.4-15: Disassembly B28HB | B28H | B28HV

4.9.4 Mounting the drill chuck B24H and B28H (B, Vario)

The keyless drill chuck is secured through a form-fit union (driver) against twisting in the drill spindle.

A friction-locking union holds and centers the keyless drill chuck with the taper mandrel in the drill spindle.

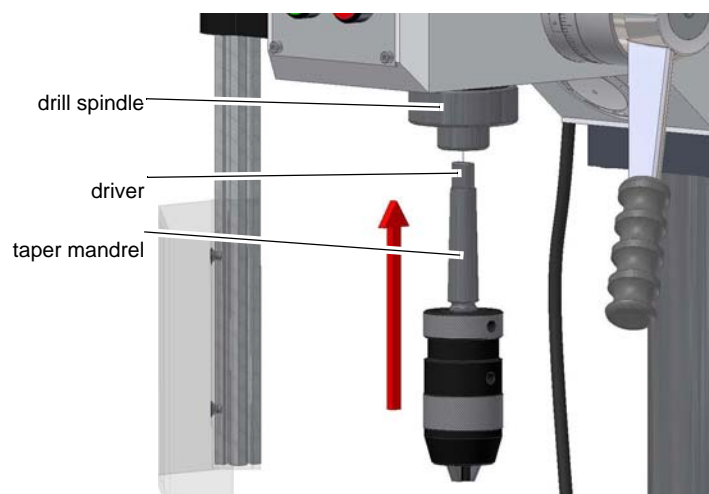

Fig.4-16: taper mandrel

- Check and if necessary, clean the conical seat in the drill spindle and at the taper mandrel of the tool or the keyless drill chuck.
- Press the taper mandrel into the drill spindle.

4.10 Cooling

The friction generated during rotation can cause the edge of the tool to become very hot.

The tool should be cooled during the drilling process. Cooling the tool with a suitable cooling lubricant ensures better working results and a longer edge life of the tools.

This is best realised by a separate cooling equipment. If there is no cooling equipment included in the delivery volume, you can cool by means of a spray gun or a washing bottle.

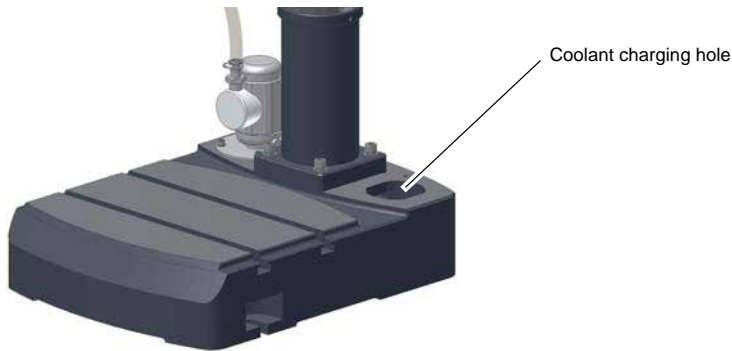

Fig.4-17: Charging hole B28HV

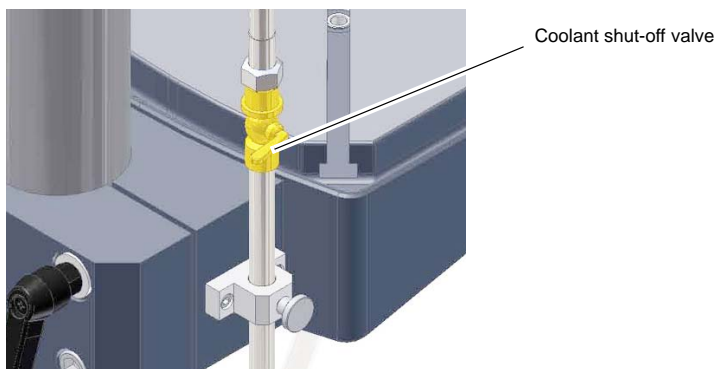

Fig.4-18: Coolant shut-off valve B28HV

→ Adjust the flow using the shut-off valve.

ATTENTION!

Failure of the pump in the event of a dry run.

The pump is lubricated by the cooling agent. Do not start up the pump without cooling agent.



CAUTION!

Danger of injury due to brushes getting caught or pulled in.

Use a spray gun or a washing bottle for cooling.



INFORMATION

Use a water-soluble and non-pollutant drilling emulsion which can be obtained from authorized distributors.

Make sure that the cooling agent is being collected.

Respect the environment when disposing any lubricants and cooling agents.

Follow the manufacturer's disposal instructions.



4.11 Before starting the working process

Before you start working, select the required speed. It is depending on the drilling diameter and on the material used.

☞ "Speed table B24H" on page 40, ☞ "Speed table B28H - B28HB" on page 40

WARNING!

For drilling jobs, it is necessary to clamp the workpiece firmly to prevent the bit catching on the pieces. Example of suitable clamping devices include a machine vice or clamping jaws.



Put a wooden or plastic board beneath the workpiece to avoid drilling through to the work table, vice, etc.

Use the drill depth stop when you want to have several bore holes with the same depth.

When working with wood, make sure to use an adequate dust extraction unit, as sawdust can constitute a health hazard. Also use a suitable protective mask for any work that generates dust.

4.12 During the working process

The spindle feed is being performed by the star grip. Make sure that the feed is being at a regular pace and not too fast.

The reset of the spindle is being performed by a track recoil spring.

WARNING!

Danger of clothing / or long hair getting caught.

- **Make sure to wear a well-fitting work suit during drilling work.**
- **Do not use gloves.**
- **If necessary, wear a hairnet.**



CAUTION!

Danger of bumps by the levers on the star grip.

Do not release the star grip when repositioning the drill spindle sleeve.



CAUTION!

Danger of crushing! Do not place your hand between the drill head and the spindle sleeve.



The smaller the bit, the more likely it is to break.

In the case of deep drilling, remove the bit from time to time to remove drilling chips from the bore hole. A few drops of oil will reduce friction and prolong the service life of the bit.



5 Determining the cutting speed and the speed

5.1 Table cutting speeds / infeed

Material table						
Material to be processed	Recommended cutting speed V_c in m/min	Recommended infeed f in mm/revolution				
		Drill bit diameter d in mm				
		2...3	>3...6	>6...12	>12...25	>25...50
Unalloyed construction steels < 700 N/mm ²	30 - 35	0.05	0.10	0.15	0.25	0.35
Alloyed construction steels > 700 N/mm ²	20 - 25	0.04	0.08	0.10	0.15	0.20
Alloyed steels < 1000 N/mm ²	20 - 25	0.04	0.08	0.10	0.15	0.20
Steels, low stability < 800 N/mm ²	40	0.05	0.10	0.15	0.25	0.35
Steel, high stability > 800 N/mm ²	20	0.04	0.08	0.10	0.15	0.20
non-rust steels > 800 N/mm ²	12	0.03	0.06	0.08	0.12	0.18
Cast iron < 250 N/mm ²	15 - 25	0.10	0.20	0.30	0.40	0.60
Cast iron > 250 N/mm ²	10 - 20	0.05	0.15	0.25	0.35	0.55
CuZn alloy brittle	60 - 100	0.10	0.15	0.30	0.40	0.60
CuZn alloy ductile	35 - 60	0.05	0.10	0.25	0.35	0.55
Aluminum alloy up to 11% Si	30 - 50	0.10	0.20	0.30	0.40	0.60
Thermoplastics	20 - 40	0.05	0.10	0.20	0.30	0.40
Thermosetting materials with organic filling	15 - 35	0.05	0.10	0.20	0.30	0.40
Thermosetting materials with anorganic filling	15 - 25	0.05	0.10	0.20	0.30	0.40

5.2 Speed table

V_c in m/min	4	6	8	10	12	15	18	20	25	30	35	40	50	60	80	100
Drill bit \varnothing in mm	Speed n in rpm															
1.0	1274	1911	2548	3185	3822	4777	5732	6369	7962	9554	11146	12739	15924	19108	25478	31847
1.5	849	1274	1699	2123	2548	3185	3822	4246	5308	6369	7431	8493	10616	12739	16985	21231
2.0	637	955	1274	1592	1911	2389	2866	3185	3981	4777	5573	6369	7962	9554	12739	15924
2.5	510	764	1019	1274	1529	1911	2293	2548	3185	3822	4459	5096	6369	7643	10191	12739
3.0	425	637	849	1062	1274	1592	1911	2123	2654	3185	3715	4246	5308	6369	8493	10616
3.5	364	546	728	910	1092	1365	1638	1820	2275	2730	3185	3640	4550	5460	7279	9099
4.0	318	478	637	796	955	1194	1433	1592	1990	2389	2787	3185	3981	4777	6369	7962
V_c in m/min	4	6	8	10	12	15	18	20	25	30	35	40	50	60	80	100

Drill bit Ø in mm	Speed n in rpm															
	283	425	566	708	849	1062	1274	1415	1769	2123	2477	2831	3539	4246	5662	7077
4.5	283	425	566	708	849	1062	1274	1415	1769	2123	2477	2831	3539	4246	5662	7077
5.0	255	382	510	637	764	955	1146	1274	1592	1911	2229	2548	3185	3822	5096	6369
5.5	232	347	463	579	695	869	1042	1158	1448	1737	2027	2316	2895	3474	4632	5790
6.0	212	318	425	531	637	796	955	1062	1327	1592	1858	2123	2654	3185	4246	5308
6.5	196	294	392	490	588	735	882	980	1225	1470	1715	1960	2450	2940	3920	4900
7.0	182	273	364	455	546	682	819	910	1137	1365	1592	1820	2275	2730	3640	4550
7.5	170	255	340	425	510	637	764	849	1062	1274	1486	1699	2123	2548	3397	4246
8.0	159	239	318	398	478	597	717	796	995	1194	1393	1592	1990	2389	3185	3981
8.5	150	225	300	375	450	562	674	749	937	1124	1311	1499	1873	2248	2997	3747
9.0	142	212	283	354	425	531	637	708	885	1062	1238	1415	1769	2123	2831	3539
9.5	134	201	268	335	402	503	603	670	838	1006	1173	1341	1676	2011	2682	3352
10.0	127	191	255	318	382	478	573	637	796	955	1115	1274	1592	1911	2548	3185
11.0	116	174	232	290	347	434	521	579	724	869	1013	1158	1448	1737	2316	2895
12.0	106	159	212	265	318	398	478	531	663	796	929	1062	1327	1592	2123	2654
13.0	98	147	196	245	294	367	441	490	612	735	857	980	1225	1470	1960	2450
14.0	91	136	182	227	273	341	409	455	569	682	796	910	1137	1365	1820	2275
15.0	85	127	170	212	255	318	382	425	531	637	743	849	1062	1274	1699	2123
16.0	80	119	159	199	239	299	358	398	498	597	697	796	995	1194	1592	1990
17.0	75	112	150	187	225	281	337	375	468	562	656	749	937	1124	1499	1873
18.0	71	106	142	177	212	265	318	354	442	531	619	708	885	1062	1415	1769
19.0	67	101	134	168	201	251	302	335	419	503	587	670	838	1006	1341	1676
20.0	64	96	127	159	191	239	287	318	398	478	557	637	796	955	1274	1592
21.0	61	91	121	152	182	227	273	303	379	455	531	607	758	910	1213	1517
22.0	58	87	116	145	174	217	261	290	362	434	507	579	724	869	1158	1448
23.0	55	83	111	138	166	208	249	277	346	415	485	554	692	831	1108	1385
24.0	53	80	106	133	159	199	239	265	332	398	464	531	663	796	1062	1327
25.0	51	76	102	127	153	191	229	255	318	382	446	510	637	764	1019	1274
26.0	49	73	98	122	147	184	220	245	306	367	429	490	612	735	980	1225
27.0	47	71	94	118	142	177	212	236	295	354	413	472	590	708	944	1180
28.0	45	68	91	114	136	171	205	227	284	341	398	455	569	682	910	1137
29.0	44	66	88	110	132	165	198	220	275	329	384	439	549	659	879	1098
30.0	42	64	85	106	127	159	191	212	265	318	372	425	531	637	849	1062
31.0	41	62	82	103	123	154	185	205	257	308	360	411	514	616	822	1027
32.0	40	60	80	100	119	149	179	199	249	299	348	398	498	597	796	995
33.0	39	58	77	97	116	145	174	193	241	290	338	386	483	579	772	965
34.0	37	56	75	94	112	141	169	187	234	281	328	375	468	562	749	937
35.0	36	55	73	91	109	136	164	182	227	273	318	364	455	546	728	910
36.0	35	53	71	88	106	133	159	177	221	265	310	354	442	531	708	885
37.0	34	52	69	86	103	129	155	172	215	258	301	344	430	516	689	861
38.0	34	50	67	84	101	126	151	168	210	251	293	335	419	503	670	838
Vc in m/min	4	6	8	10	12	15	18	20	25	30	35	40	50	60	80	100

Drill bit Ø in mm	Speed n in rpm															
	33	49	65	82	98	122	147	163	204	245	286	327	408	490	653	817
39.0	32	48	64	80	96	119	143	159	199	239	279	318	398	478	637	796
40.0	31	47	62	78	93	117	140	155	194	233	272	311	388	466	621	777
41.0	30	45	61	76	91	114	136	152	190	227	265	303	379	455	607	758
42.0	30	44	59	74	89	111	133	148	185	222	259	296	370	444	593	741
43.0	29	43	58	72	87	109	130	145	181	217	253	290	362	434	579	724
44.0	28	42	57	71	85	106	127	142	177	212	248	283	354	425	566	708
45.0	28	42	55	69	83	104	125	138	173	208	242	277	346	415	554	692
46.0	27	41	54	68	81	102	122	136	169	203	237	271	339	407	542	678
47.0	27	40	53	66	80	100	119	133	166	199	232	265	332	398	531	663
48.0	26	39	52	65	78	97	117	130	162	195	227	260	325	390	520	650
49.0	25	38	51	64	76	96	115	127	159	191	223	255	318	382	510	637
50.0																

5.3 Examples to calculatory determine the required speed for your drilling machine

The necessary speed is depending on the diameter of the drill bit, on the material which is being machined as well as on the cutting material of the drill bit.

Material which needs to be drilled: St37

Cutting material (drill bit): HSS spiral bit

Set point of the cutting speed [v_c] according to the table: 40 meters per minute

Diameter [d] of your drill bit: 30 mm = 0.03 m [meters]

Selected infeed [f] according to the table: about 0.35 mm/rev

$$\text{Speed } n = \frac{v_c}{\pi \times d} = \frac{40 \text{ m}}{\text{min} \times 3,14 \times 0,03 \text{ m}} = 425(\text{rpm})$$

Set a speed on your drilling machine which is less than the determined speed.

INFORMATION

In order to facilitate the production of larger drill holes they need to be pre-drilled. This way, you reduce the cutting forces and improve the guiding of the drill bit.

The pre-drilling diameter is depending on the length of the chisel edge. The chisel edge does not cut, but it squeezes the material. The chisel edge is positioned at an angle of 55° to the major cutting edge.

As a general rule of thumb it applies: The pre-drilling diameter is depending on the length of the chisel edge.

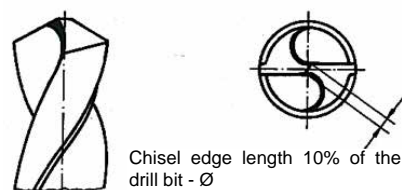

Recommended working steps for a drilling diameter of 30 mm

Example:

1st working step: Pre-drilling with Ø 5 mm (0.2").

2nd working step: Pre-drilling with Ø 15 mm (0.6").

3rd working step: Drilling with Ø 30 mm (1.2").

6 Maintenance

In this chapter you will find important information about

- inspection,
- maintenance,
- repair.

The diagram below shows which of these headings each task falls under.

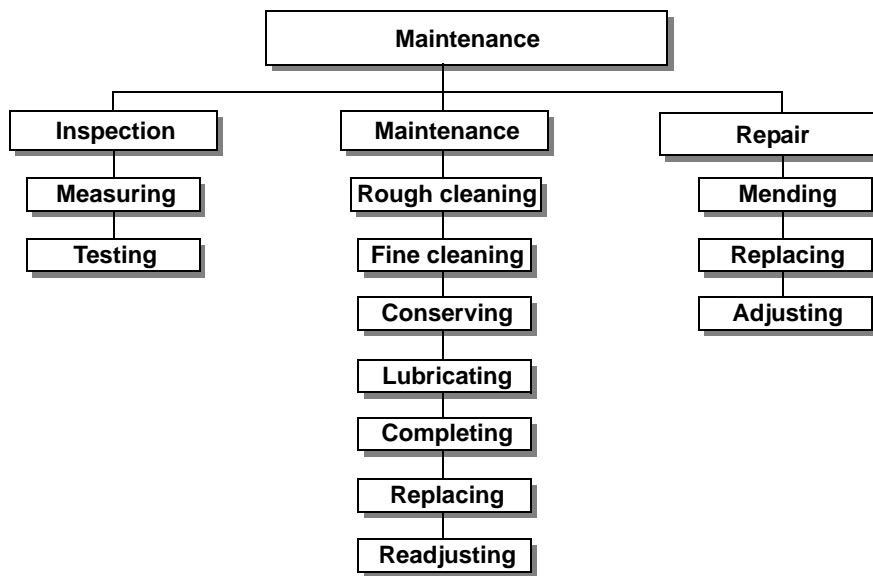

Fig.6-1: Maintenance – Definition according to DIN 31051

ATTENTION!

Properly performed regular maintenance is an essential prerequisite for

- safe operation,
- faulty-free operation,
- long service life of the machine and
- the quality of the products you manufacture.

Installation and equipment from other manufacturers must be in company condition.

ENVIRONMENTAL PROTECTION

During work on the drilling head, make sure that

- collector vessels are used, with sufficient capacity for the amount of liquid to be collected.
- liquid and oils are not split on the ground.

Clean up any split liquids or oils immediately using proper oil-absorption methods and dispose of them in accordance with current legal requirements on the environment.

Cleaning up spills

Do not re-introduce liquids spilt outside the system during repair or as result of leakage from the reserve tank: collect them in a collecting vessel to be disposed of.

Disposal

Never dump oil or other pollutant substances in water inlets, rivers or channels.

Used oils must be delivered to a collection centre. Consult your superior if you do not know where the collection centre is.



6.1 Safety

WARNING!

The consequences of incorrect maintenance and repair work may include:

- very serious injury to employees working on the machine,
- damage to the machine.

Only qualified staff should carry out maintenance and repair work on the machine.



6.1.1 Preparation

WARNING!

Only carry out work on the machine if it has been disconnected from the main power supply.

Position a warning sign.



6.1.2 Restarting

Before restarting run a safety check.

👉 "Safety check" on page 11

WARNING!

Before activating the machine, double check that this will not

- endanger other people,
- damage the machine.





6.2 Inspection and maintenance

This type and extent of wear depends to a large extent on individual usage and service conditions. For this reason, all the intervals are only valid for the authorized conditions.

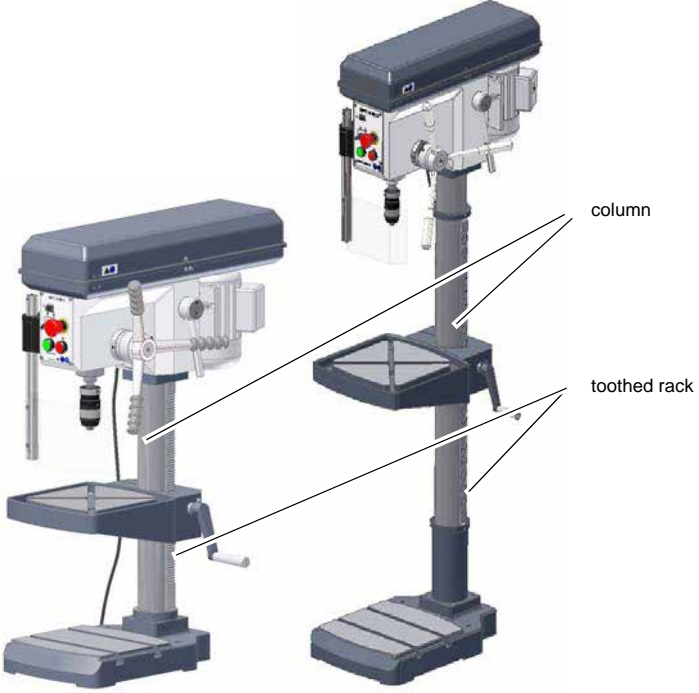
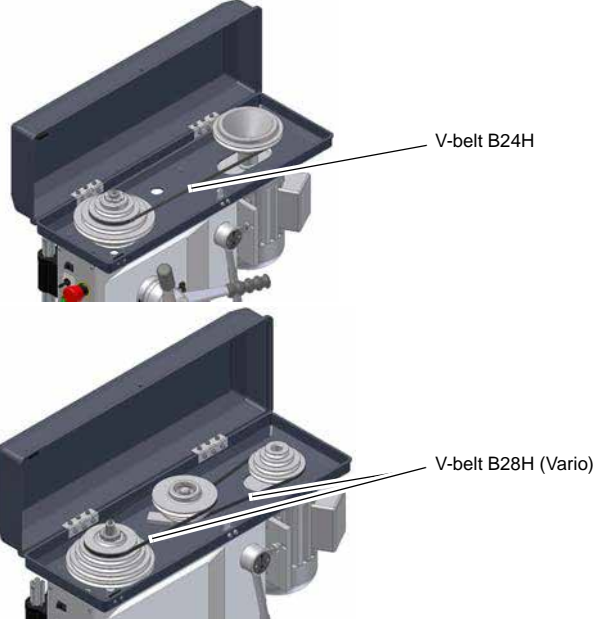
Interval	Where?	What?	How?
start of shift after each maintenance or repair operation	bench drill and upright drill	Examination for outside damages. 👉 "Safety check" on page 11	

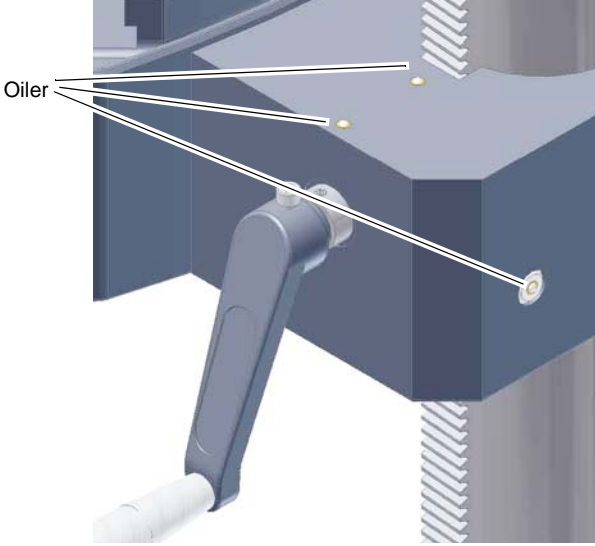
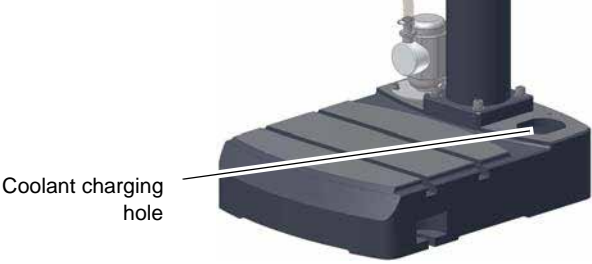
Interval	Where?	What?	How?
every month	column and rack	lubricate	<ul style="list-style-type: none"> Lubricate the column with commercial oil, machine oil, motor oil. Lubricate the rack regularly with commercial grease (e.g. friction bearing grease).  <p>column</p> <p>toothed rack</p> <p>Img. 6-2: B24H B28HB B28H B28HV</p>
every six months	V-belts on the drilling head	visual inspection	<ul style="list-style-type: none"> Check whether the V-belts have become porous and worn.  <p>V-belt B24H</p> <p>V-belt B28H (Vario)</p> <p>Img. 6-3: V-belt housing</p>

Interval	Where?	What?	How?
every month	Oiler	Lubricate	<p>➔ Lubricate all oilers with machine oil, do not use a grease gun or similar greasing equipment. Use the oil bottle in included with the machine.</p> <p>📖 "Operating material" on page 17</p>  <p>Fig.6-4: Oiler B24H B28HB B28H B28HV</p>
every six months	electric	check	<p>Check the electrical equipment / parts of the drilling machine.</p> <p>📖 "Qualification of employees" on page 9</p>
			<p>➔ The cooling pump is almost entirely maintenance-free. Replace the cooling agent regularly, depending on usage.</p> <p>➔ When using coolants which leave residues, the coolant pump must be removed and rinsed possibly.</p> <p>➔ Suck the old cooling agent off with a suitable industrial suction cup over the charging hole.</p> <p>➔ Fill in new coolant over the chip tray. The maximum capacity of the coolant is about 3.7 quarts.</p>  <p>Fig.6-5: Coolant tank B28HV</p>

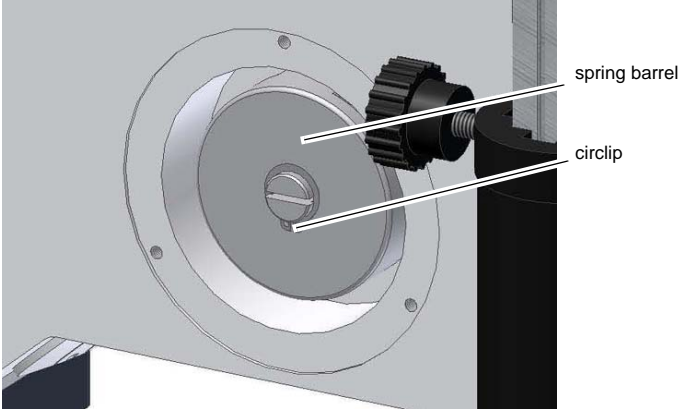
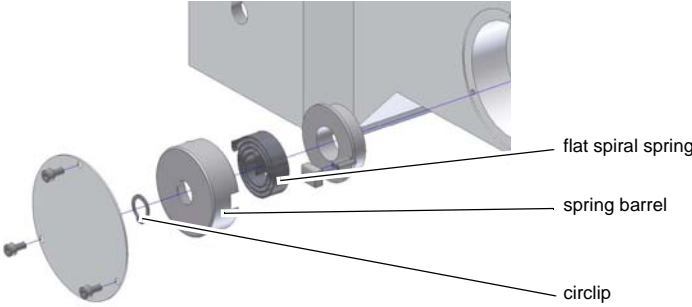
Interval	Where?	What?	How?
as required	spindle return spring	adjust stretch return spring	<p>CAUTION!  Parts will throw out at high pressure. When disassembling, make sure that only skilled staff will maintain and repair the machine.</p>  <p>Img.6-6: Spindle return spring</p>  <p>Img.6-7: Exploded view of the spring barrel</p>

INFORMATION!

The spindle bearing arrangement is prelubricated. It is not required to relubricate it.



6.3 Repair

Repairs must be carried out only by qualified technical staff; and must follow the instructions and guidelines given in this manual. Should technical assistance be required, contact C.H.HANSON at 1-630-785-6437.

Company and C.H.HANSON are not liable for, nor do they guarantee against, damage or operating malfunctions resulting from alteration, abuse, lack of maintenance or this product's use for other than its intended purpose. Failure to read and follow this operating manual is not covered.

For repairs only use

- Proper and suitable tools,
- Parts purchased from company, or its authorized agent.

7 Spare parts - B24H | B28H | B28HB | B28HV

7.1 B24H

7.1.1 Drilling head B24H

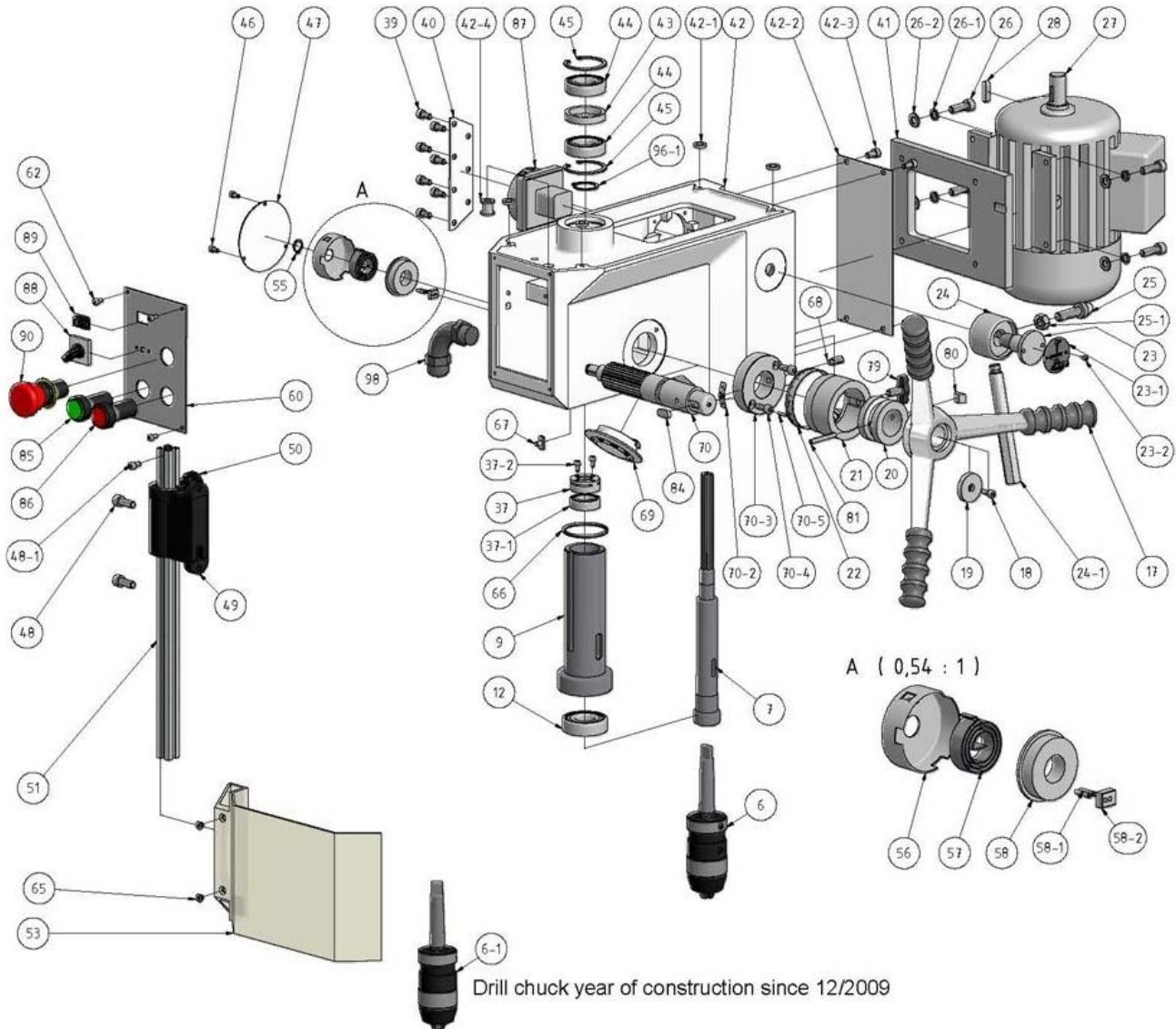

Fig.7-1: Drilling head B24H

7.1.2 Column and drilling table B24H

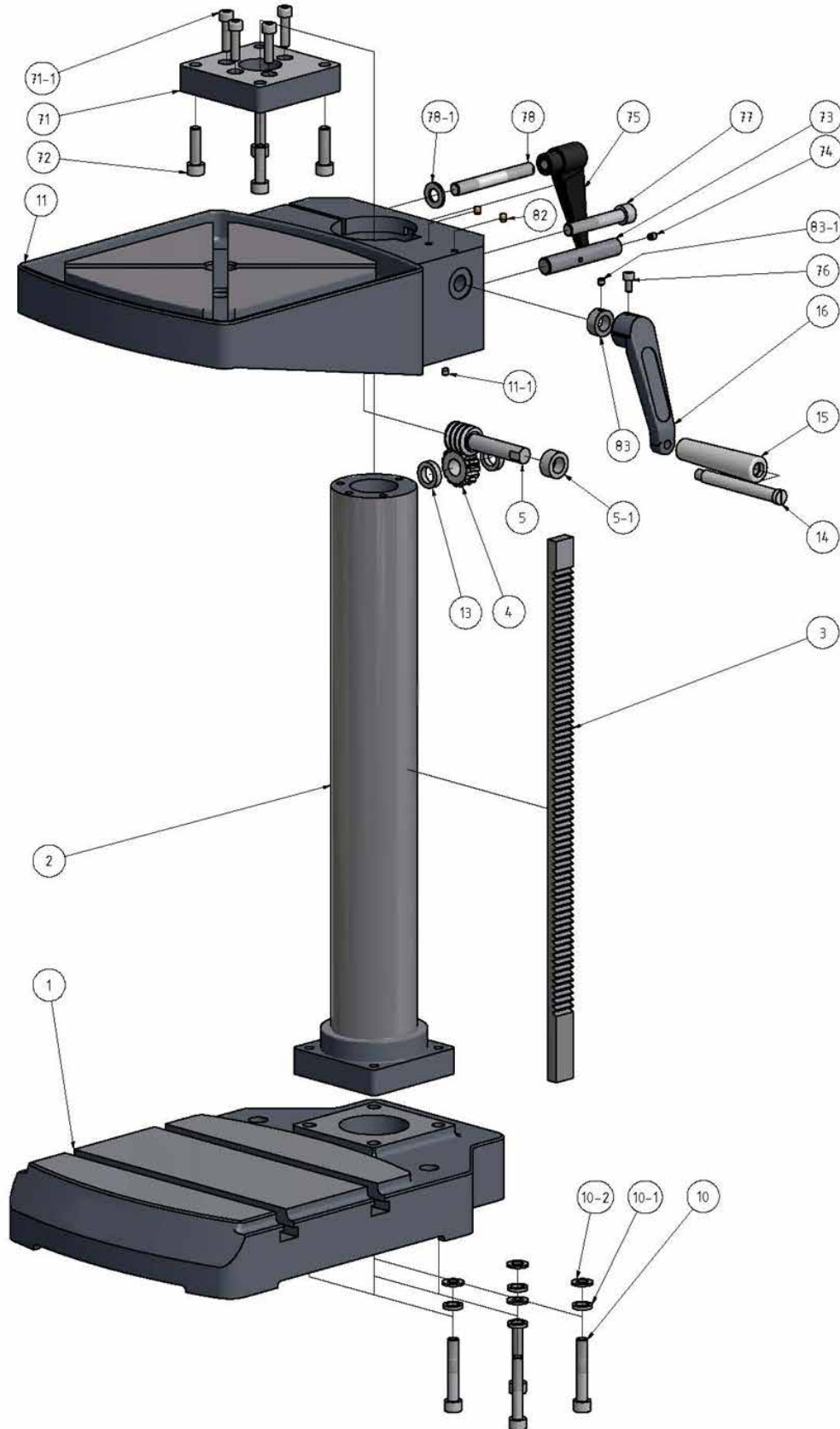

Fig. 7-2: Column and drilling table B24H

7.1.3 Pulleys B24H

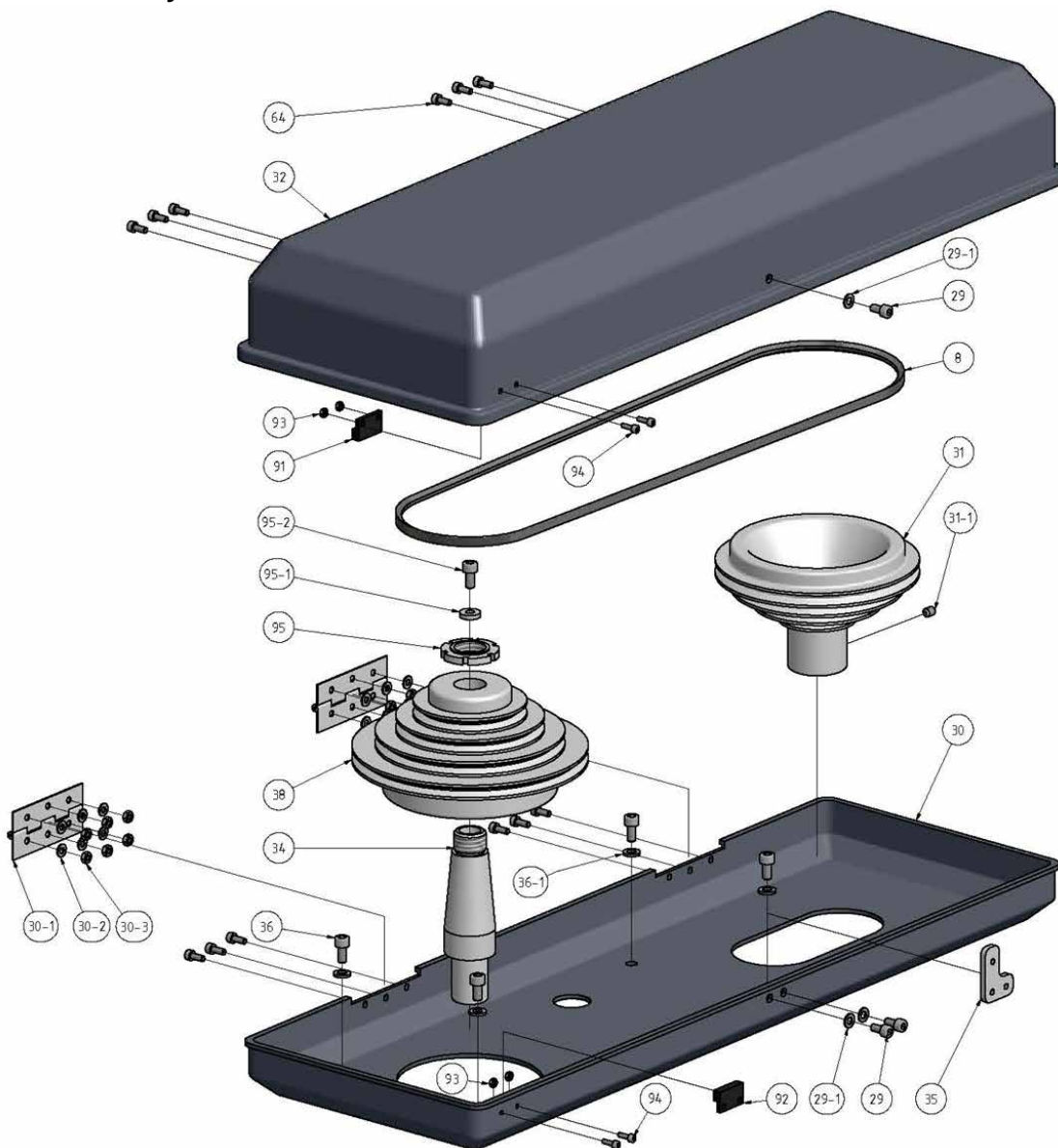

Fig.7-3: Pulleys B24H

7.1.4 Parts list B24H

B24H				
Pos.	Description	Qty.	Size	Item no.
1	Base	1		030202411
2	Column	1		030202412
3	Toothed rack	1		030202413
4	Toothed wheel	1		030202414
5	Drive screw	1		030202415
5-1	Spacer	1		0302024151
6	Drill chuck	1	B16	030202416
6-1	Drill chuck (year on construction since 12/2009)	1		3050626
7	Spindle	1		030202417
8	V-belt	1		030202418
9	Spindle sleeve	1		030202419
10	Socket head screw	4	M10x60	0302024110
10-1	Washer	4	GB/T93-1987-10	03020241101
10-2	Washer	4	GB/T97.1-1985-10	03020241102

B24H				
Pos.	Description	Qty.	Size	Item no.
11	Drilling machine table	1		0302024111
11-1	Threaded pin	1	M6x6	03020241111
12	Ball bearing	1	6205	0302024112
13	Spacer	2		0302024113
14	Screw	1	JB-T7270.4-1994-2	0302024114
15	Case	1	JB-T7270.4-1994-1	0302024115
15-1	Handle complete	1	JB-T7270.4-1994	03020241151
16	Crank	1		0302024116
17	Spindle feed grip	1		0302024117
18	Socket head screw	1	M5x25	0302024118
19	Plate	1		0302024119
20	Bushing scale	1		0302024120
21	Scale ring	1		0302024121y
22	Scale	1		0302024122
23	Clamping screw	1		0302024123
23-1	Label „spans“ „release“	1		03020241231
23-2	Socket head screw	2	M3x10	03020241232
24	Bushing quick action grip	1		0302024124
24-1	Quick action grip	1		03020241241
25	Bolt span	1		0302024125
25-1	Hexagonal nut	1	M10	03020241251
26	Hexagon bolt	4	M8x25	0302024126
26-1	Washer	4	GB/T93-1987-8	03020241261
26-2	Washer	4	GB/T97.1-1985-8	03020241262
27	Motor	1		0302024127
28	Feather key	1	6x6x20	0302024128
29	Socket head screw	3	M5x10	0302024129
29-1	Washer	3	5	03020241291
30	Belt housing bottom part	1		0302024130
30-1	Articulation	2		03020241301
30-2	Washer	12	4	03020241302
30-3	Hexagonal nut	12	M4	03020241303
31	Pulley	1	M6x8	0302024131
31-1	Threaded pin	1		03020241311
32	Belt housing upper part	1		0302024132
34	Spindle	1		0302024134
35	Plate closer	1		0302024135
36	Socket head screw	4	M6x12	0302024136
36-1	Washer	4		03020241361
37	Spindle nut	1		0302024137
37-1	Ball bearing	1	6003-2Z	03020241371
37-2	Socket head screw	2	M4x8	03020241372
38	Pulley	1		0302024138
39	Socket head screw	7	M6x15	0302024139
40	Holder plate	1		0302024140
41	motor plate	1		0302024141
42	Drilling head	1		0302024142
42-1	Washer	4		03020241421
42-2	Plate	1		03020241422
42-3	Socket head screw	4	M6x12	03020241423
42-4	Bushing	1		030202414234
43	Spacer ring	1		0302024143
44	Ball bearing	2	6005	0302024144
45	Circlip	2	DIN472 47x1.6	0302024145
46	Socket head screw	3	M4x10	0302024146
47	Covering plate	1		0302024147
48	Socket head screw	2	M6x30	0302024148
48-1	Socket head screw	1		03020241481
49	Fixing drill chuck protection	1		0302024149
50	Knurled screw	1	M6x30	0302024150
51	Arm drill chuck protection	1	20x20	0302024151
53	View sealing pane drill chuck protection	1		0302024153
53-1	Switch drill chuck	1	230V 0,5A	03020241531
55	circlip	1	DIN471-12x1	0302024155
56	Box spiral spring	1		0302024156
57	Spiral spring	1		0302024157
58	Bushing toothed shaft	1		0302024158
58-1	Split pin	2	3x12	03020241581
58-2	Spanner spiral spring	1		03020241582

B24H

Pos.	Description	Qty.	Size	Item no.
60	Switch plate	1		0302024160
61	Switch On / OFF (old version 1.0)	1		0302024161
62	Socket head screw	4	M4x8	0302024162
63	Machine lightning switch	1	250V 6A	0302024163
64	Socket head screw	12	M4x10	0302024164
65	Socket head screw	2	M6x20	0302024165
66	O-ring	1		0302024166
67	sliding block	1		0302024167
68	Setscrew	1	M8x15	0302024168
69	Cover illumination	1		0302024169
69-1	Lamp (diode)	1	12V	03020241691
70	Shank pinion	1		0302024170
70-2	Mechanical indicator scale	1		03020241702
70-3	Ring	1		03020241703
70-4	Socket head screw	2	M6x16	03020241704
70-5	Spring pin	1		03020241705
71	Plate	1	M8x30	0302024171
71-1	Socket head screw	4		03020241711
72	Socket head screw	4	M10x25	0302024172
73	Shaft	1		0302024173
74	Oiler	1		0302024174
75	Clamping lever	1		0302024175
76	Socket head screw	1	M6x20	0302024176
77	Socket head screw	1	M12x60	0302024177
78	Clamping screw	1	M12x60	0302024178
78-1	Washer	1	12	03020241781
79	Knurled screw	1	M8x20	0302024179
80	Sliding block	1		0302024180
81	Straight pin	1	6x40	0302024181
82	Pressure Oil Cup	2		0302024182
83	Spacer	1		0302024183
83-1	Threaded pin	1	M6x6	03020241831
84	Key	1	8x8x18	0302024184
85	Bush button On	1	230V 5A	0302024185
85-1	Operating control light	1	24V	03020241851
86	Bush button Off	1	230V 5A	0302024186
87	Main switch	1	660V 20A	0302024187
88	Switch for direction of rotation	1	250V 24V/12A 50Hz	0302024188
89	Light switch	1	250V 6A	0302024189
90	Emergency- stop switch	1	600V 10A	0302024190
91	Counterpart reed contact	1		0302024191
92	Reed contact	1	PS-3150	0302024192
93	Nut	4	M4	0302024193
94	Socket head screw	4	M3x10	0302024194
95	Groove nut	1	M22x1,5	0302024195
95-1	Washer	1	6	03020241951
95-2	Socket head screw	1	M6x12	03020241952
96-1	Circlip	1		03020241961
98	Cable discharge	1		0302024198
0	Transformer (without illustration)	1		0302024196
0	Contacteur (without illustration)	1	230V 16A	0302024197

7.1.5 Wiring diagram B24H - 115V, 60 Hz

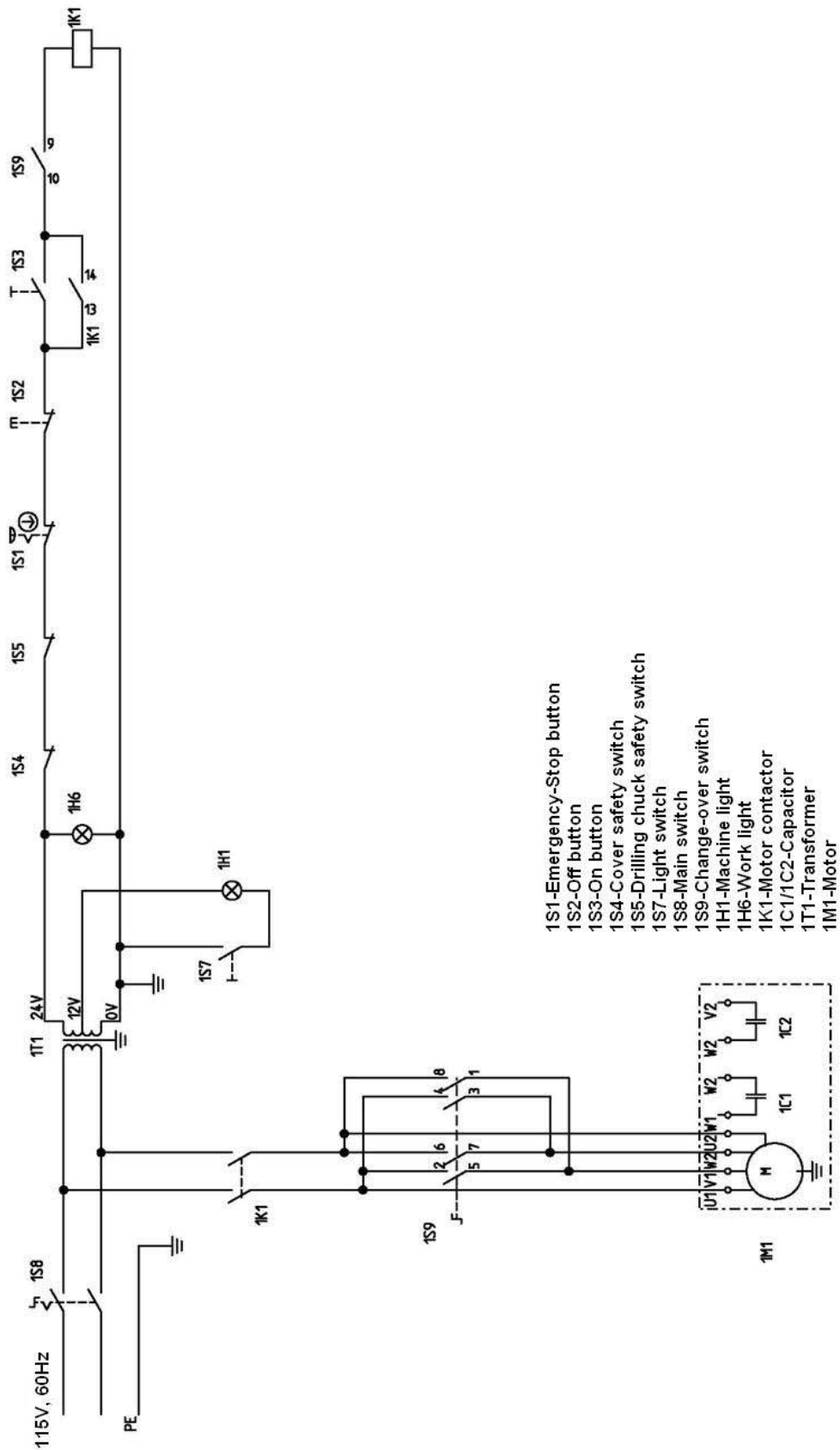
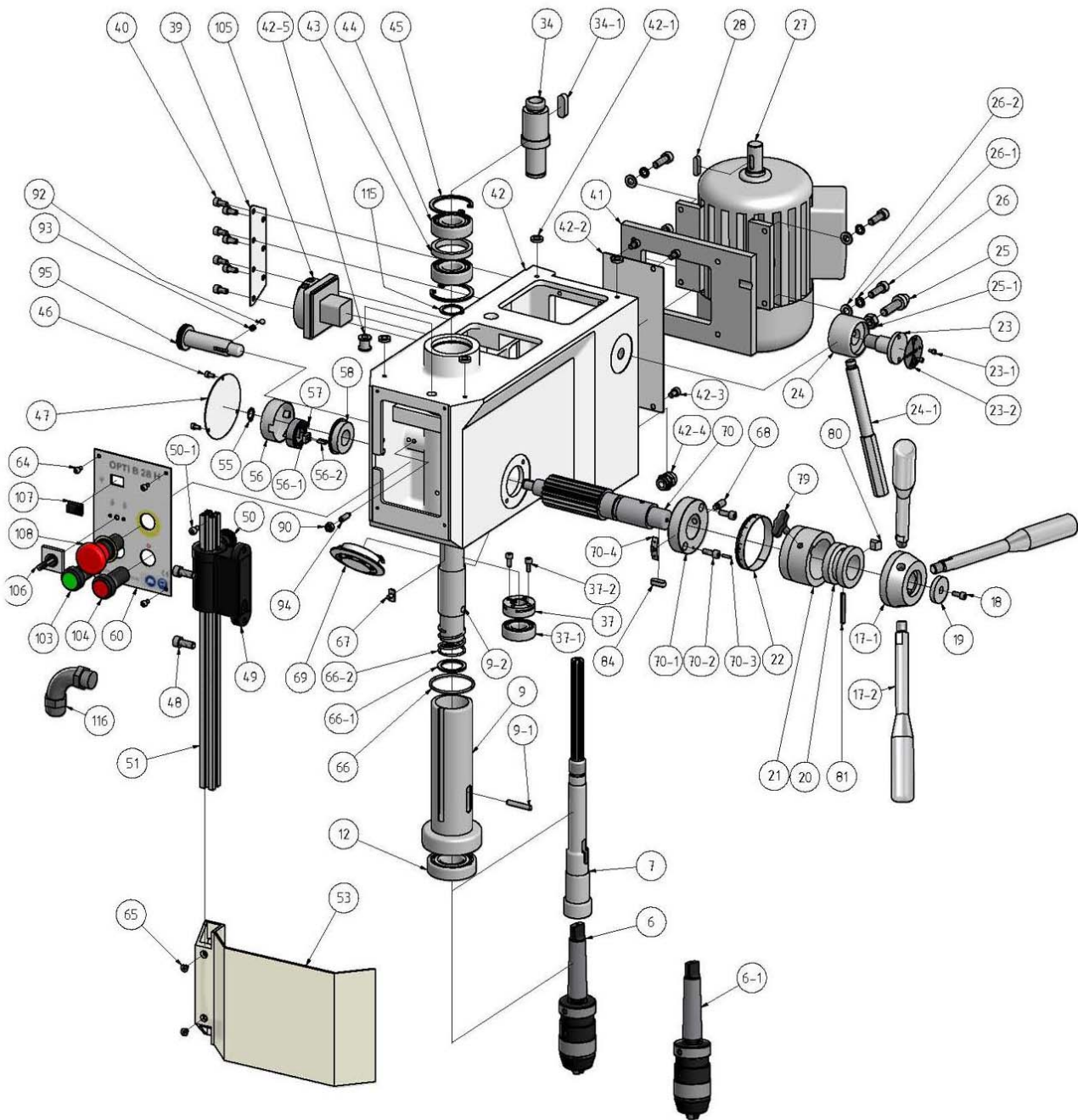

Fig. 7-4: Wiring diagram B24H - 115V

7.2 B28H | B28HB

7.2.1 Drilling head B28H | B28HB



Drill chuck year of construction since 12/2009

Fig.7-5: Drilling head B28H | B28HB

7.2.2 Column and drilling table B28H

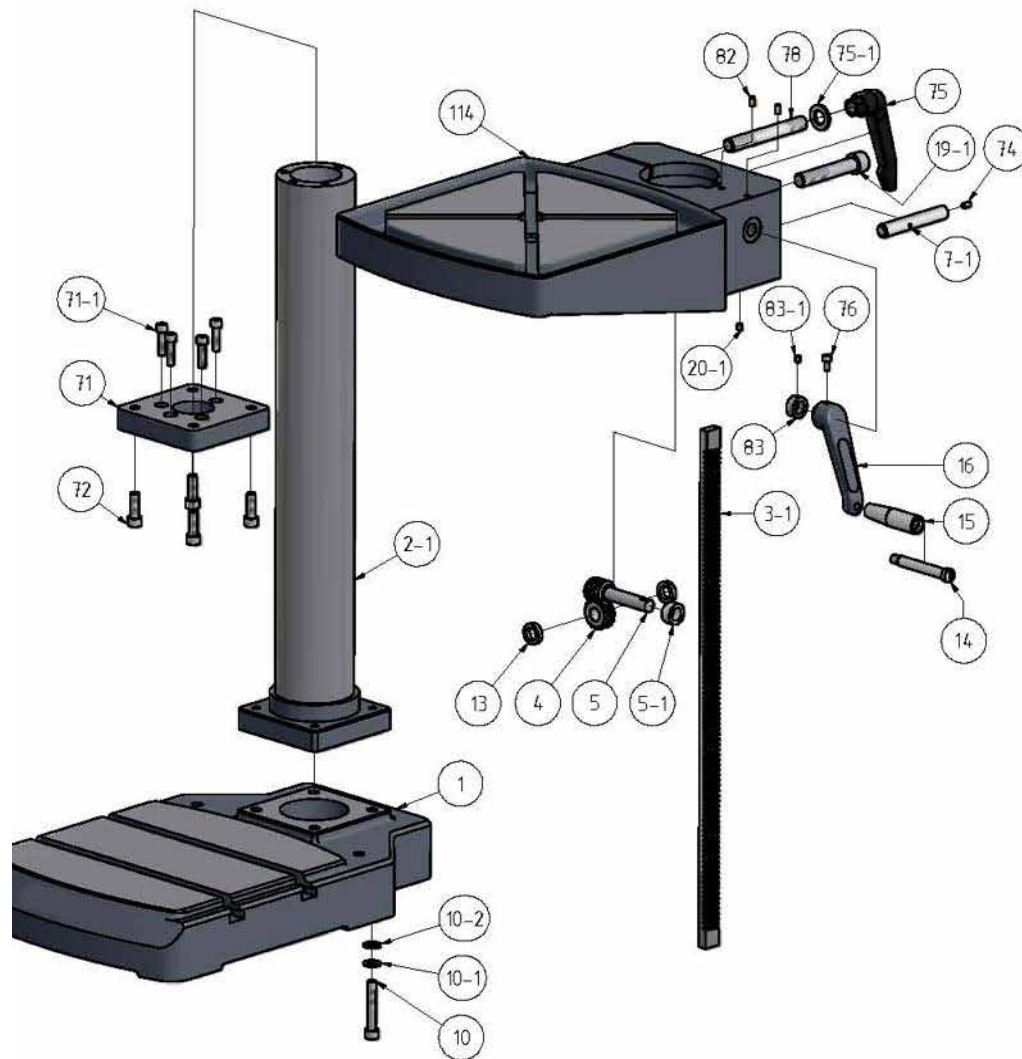
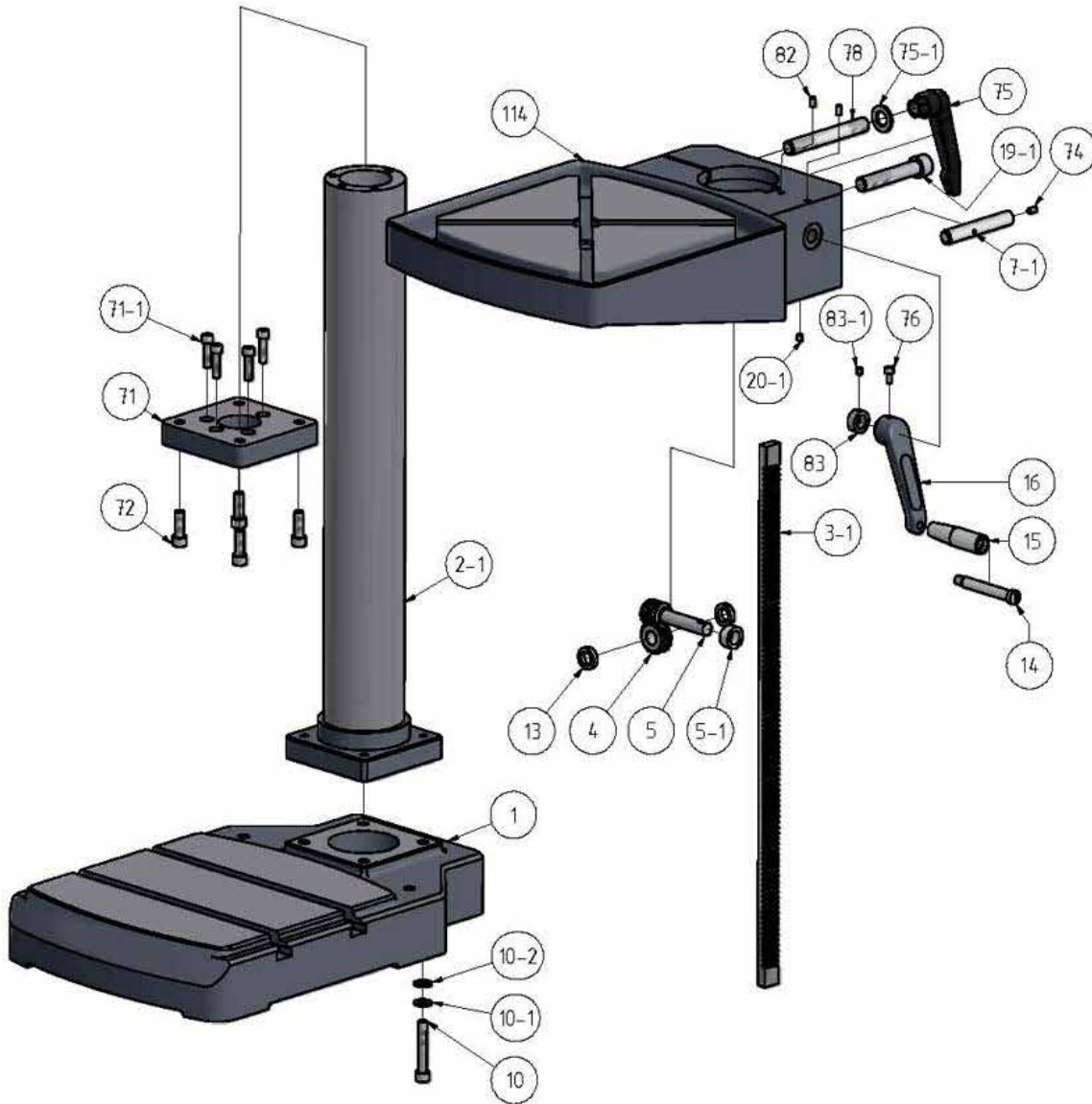

Fig. 7-6: Column and drilling table B28H

7.2.3 Column and drilling table B28HB



Column and drilling table B28HB

7.2.4 Pulleys B28H | B28HB

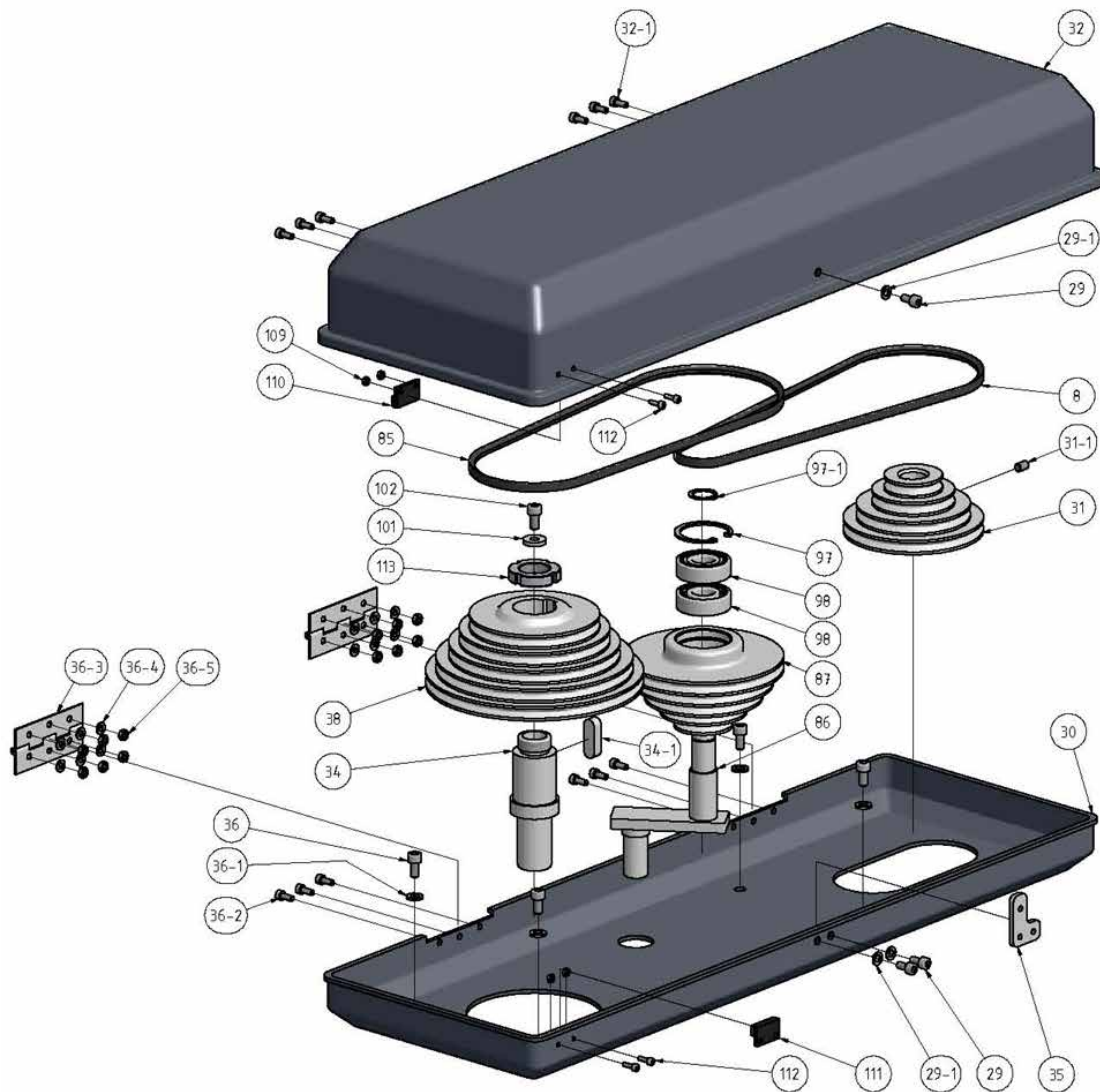

Fig. 7-7: Pulleys B28H

7.2.5 Parts list B28H | B28HB

B28H, B28HB				
Pos.	Description	Qty.	Size	Item no.
1	Base	1		030202831
2	Column	1		030202832
2-1	Column B28HB	1		0302025202
3	Toothed rack	1		030202833
3-1	Toothed rack B28HB	1		0302025203
4	Toothed wheel	1		030202834
5	Drive screw	1		030202835
5-1	Distance plate	1		0302028351
6	Drill chuck	1	B16	030202836
6-1	Drill chuck (year on construction since 12/2009)	1		3050626
7	Spindle	1		030202837
7-1	Shaft	1		0302028371
8	V-belt	1		030202838
9	Spindle sleeve	1		030202839
9-1	Spring pin	1	5x40	0302028391
9-2	Bushing	1		0302028392
10	Socket head screw	4	M12x60	0302028310
10-1	Washer	4	GB/T93-1987-12	03020283101
10-2	Washer	4	GB/T97.1-1985-12	03020283102
12	Ball bearing	1	6206	0302028312
13	Distance plate	2		0302028313
14	Screw	1	JB-T7270.4-1994-2	0302028314
15	Grip	1	JB-T7270.4-1994-1	0302028315
15-1	Grip complete	1	JB-T7270.4-1994	03020283151
16	Crank	1		0302028316
17	Spindle sleeve feed grip old version	1		0302028317
17-1	Fixture sleeve handle	1		03020283171
17-2	Spindle sleeve handle	3		0302130332
18	Socket head screw	1	M5x20	0302028318
19	Washer	1		0302028319
19-1	Socket head screw	1	M16x90	03020283191
20	Bushing hup scalering	1		03020283201
20-1	Threaded pin	1	M6x6	0302028320
21	Scale ring	1		0302028321
22	Scale	1		0302028322
23	Clamping screw	1		0302028323
23-1	Socket head screw	2	M3x10	03020283231
23-2	Label „spans“ „release“	1		03020283232
24	Bushing quick action grip	1		0302028324
24-1	Quick action grip	1		03020283241
25	Bolt	1		0302028325
25-1	Hexagonal nut	1		0302028325
26	hexagon bolt	4	M8x25	0302028326
26-1	Washer	4	GB/T93-1987-8	03020283261
26-2	Washer	4	GB/T97.1-1985-8	03020283262
27	Motor	1		0302028327
28	Feather key	1	6x6x20	0302028328
29	Socket head screw	3	M5x10	0302028329
29-1	Washer	2	5	03020283291
30	Belt housing base	1		0302028330
31	Pulley	1		0302028331
31-1	Threaded pin	1		03020283311
32	Belt housing upper part	1		0302028332
32-1	Socket head screw	6	M5x10	03020283321
34	Washer	1		0302028334
34-1	Feather key	1		03020283341
35	Plate closer	1		0302028335
36	Socket head screw	4	M6x15	0302028336
36-1	Washer	4		03020283361
36-2	Socket head screw	4		03020283362
36-3	Articulation	2		03020283363
36-4	Washer	12		03020283364
36-5	Hexagonal nut	12		03020283365
37	Spindle nut	1		0302028337
37-1	Ball bearing	1	6004-2Z	03020283371
37-2	Socket head screw	2		03020283372

B28H, B28HB

Pos.	Description	Qty.	Size	Item no.
38	Pulley	1		0302028338
39	Socket head screw	1		0302028339
40	Socket head screw	7	M6x15	0302028340
41	Motor plate	1		0302028341
42	Drilling head	1		0302028342
42-1	Washer	4		03020283421
42-2	Plate	1		03020283422
42-3	Socket head screw	4	M6x10	03020283423
42-4	Cable connection	2		03020283424
42-5	Bushing	1		03020283425
43	Spacer ring	1		0302028343
44	Ball bearing	2	6205-2R	0406205.2R
45	Circlip	2	DIN472 47x1.6	0302028345
46	Socket head screw	3	M4x10	0302028346
47	Covering plate	1		0302028347
48	Socket head screw	2	M6x30	0302028348
49	Fixing	1		0302028349
50	Knurled screw	1	M6x30	0302028350
50-1	Socket head screw	1	M5x10	03020283501
51	Alu- profile	1	20x20	0302028351
53	View sealing pane drill chuck protection	1		0302028353
53-1	Switch drill chuck	1	230V 0,5A	03020241531
55	Circlip	1	DIN471-12x1	0302028355
56	Box	1		0302028356
56-1	Spanner spiral spring	1		03020283561
56-2	Split pin	2	3x12	03020283562
57	Recuperating spring	1		0302028357
58	recuperating spring seat	1		0302028358
60	Switch plate	1		0302028360
60-1	Switch plate complete	1		03020241119
64	Socket head screw	4	M4x10	0302028364
65	Countersunk screw	2	M5x10	0302028365
66	O-ring	1		0302028366
66-1	Washer	1		03020283661
66-2	Spring	1		03020283662
67	Sliding block	1		0302028367
68	Setscrew	1	M8x15	0302028368
69	Machine illumination	1		0302028369
69-1	Lamp (diode)	1	12V	03020241691
70	Shank pinion	1		0302028370
70-1	Ring	1		03020283701
70-2	Socket head screw	2	M6x16	03020283702
70-3	Spring pin	1		03020283703
70-4	Mechanicel indicator scale	1		03020283704
71	Plate	1		0302028371
71-1	Socket head screw	4	M8x30	03020283711
72	Socket head screw	4	M10x25	0302028372
74	Oiler	1		0302028374
75	Clamping lever	1		0302028375
75-1	Washer	1	16	03020283751
76	Socket head screw	1	M6x20	0302028376
78	Clamping screw	1	M16x80	0302028378
79	Knurled screw	1	M8x20	0302028379
80	Sliding block	1		0302028380
81	Straight pin	1	6x40	0302028381
82	Oiler	2		0302028382
83	Distance plate	1		0302028383
83-1	Threaded pin	1	M6x6	03020283831
84	Key	1	8x8x18	0302028384
85	V-belt	1		0302028385
86	Knee piece	1		0302028386
87	Pulley	1		0302028387
90	Hexagon nut	1	M6	0302028390
92	Ball	1		0302028392
93	Feather	1		0302028393
94	Setscrew	1	M6x20	0302028394
95	Ejector	1		0302028395
97	Circlip	2		0302028397
97-1	Circlip	1		03020283971

B28H, B28HB

Pos.	Description	Qty.	Size	Item no.
98	Bearing	2	6203	0302028398
99	Ring	1		0302028399
99-1	Ring	1		03020283991
100	Setscrew	1	M8x15	03020283100
100-1	Setscrew	1	M8x15	030202831001
101	Washer	1		03020283101
102	Socket head screw	1	M6x20	03020283102
103	Bush button On	1	230V 5A	03020283103
104	Bush button Off	1	230V 5A	0302024185
105	main switch	1	660V 20A	0302024187
106	switch for direction of rotation	1		03020283106
107	light switch	1	250V 6A	03020283107
108	emergency -stop switch	1	600V 10A	0302024190
109	Nut	4	M4	03020283109
110	Counterpart reed contact	1		03020283110
111	Reed contact	1	PS-3150	03020283111
112	Socket head screw	4	M3x10	03020283112
113	Groove nut	1	M24x1,5	03020283113
114	Drilling machine table	1		03020283114
115	Circlip	1		03020283115
116	Cable discharge	1		0302024198
0	Transformer (without illustration)	1		0302024196
0	Contactora (without illustration)	1	230V 16A	0302024197

7.3 B28HV

7.3.1 Drilling head B28HV

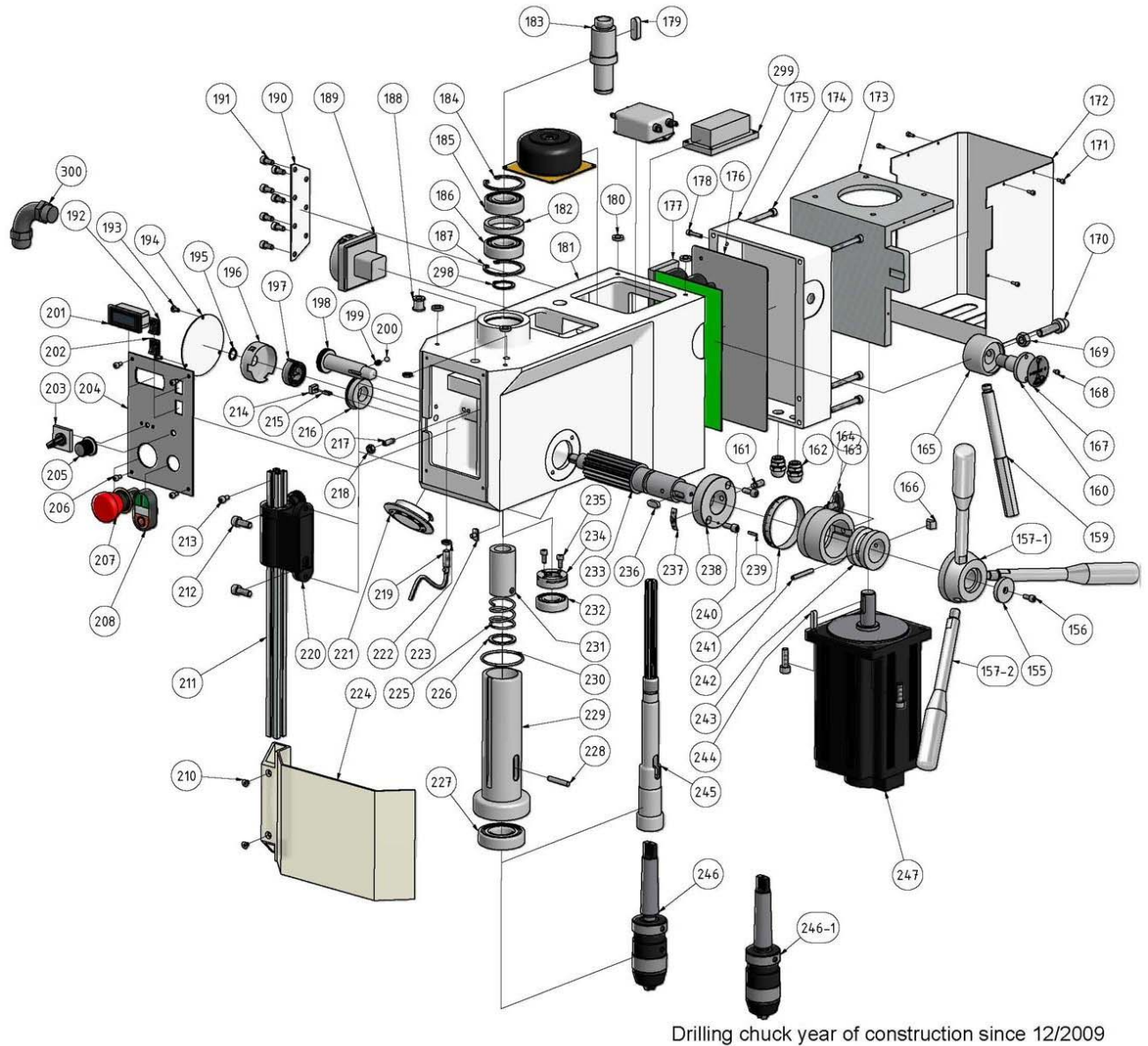

Fig. 7-8: Drilling head B28HV

7.4 Column and drilling table B28HV

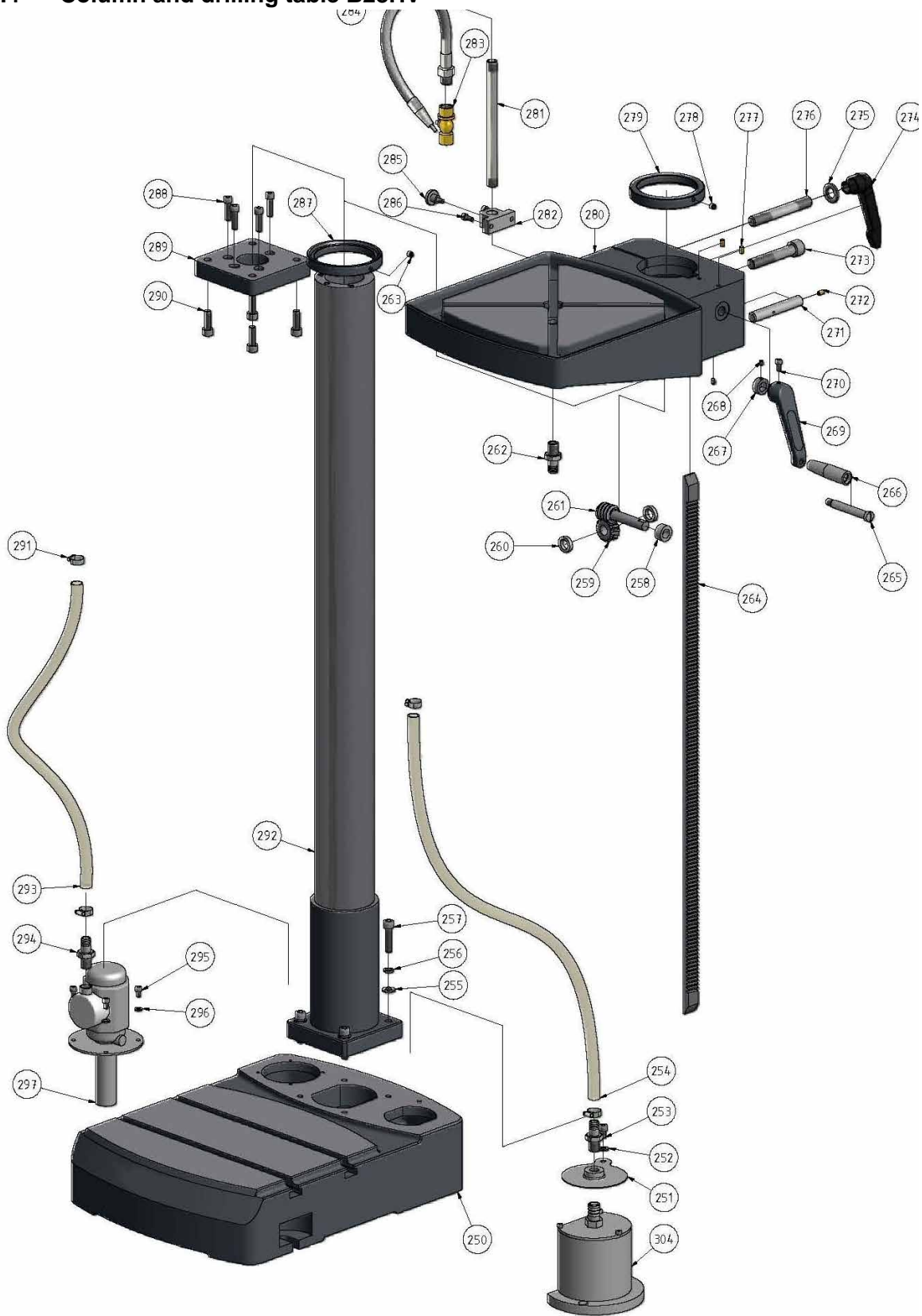

Fig.7-9: Column and drilling table B28HV

7.4.1 Pulleys B28HV

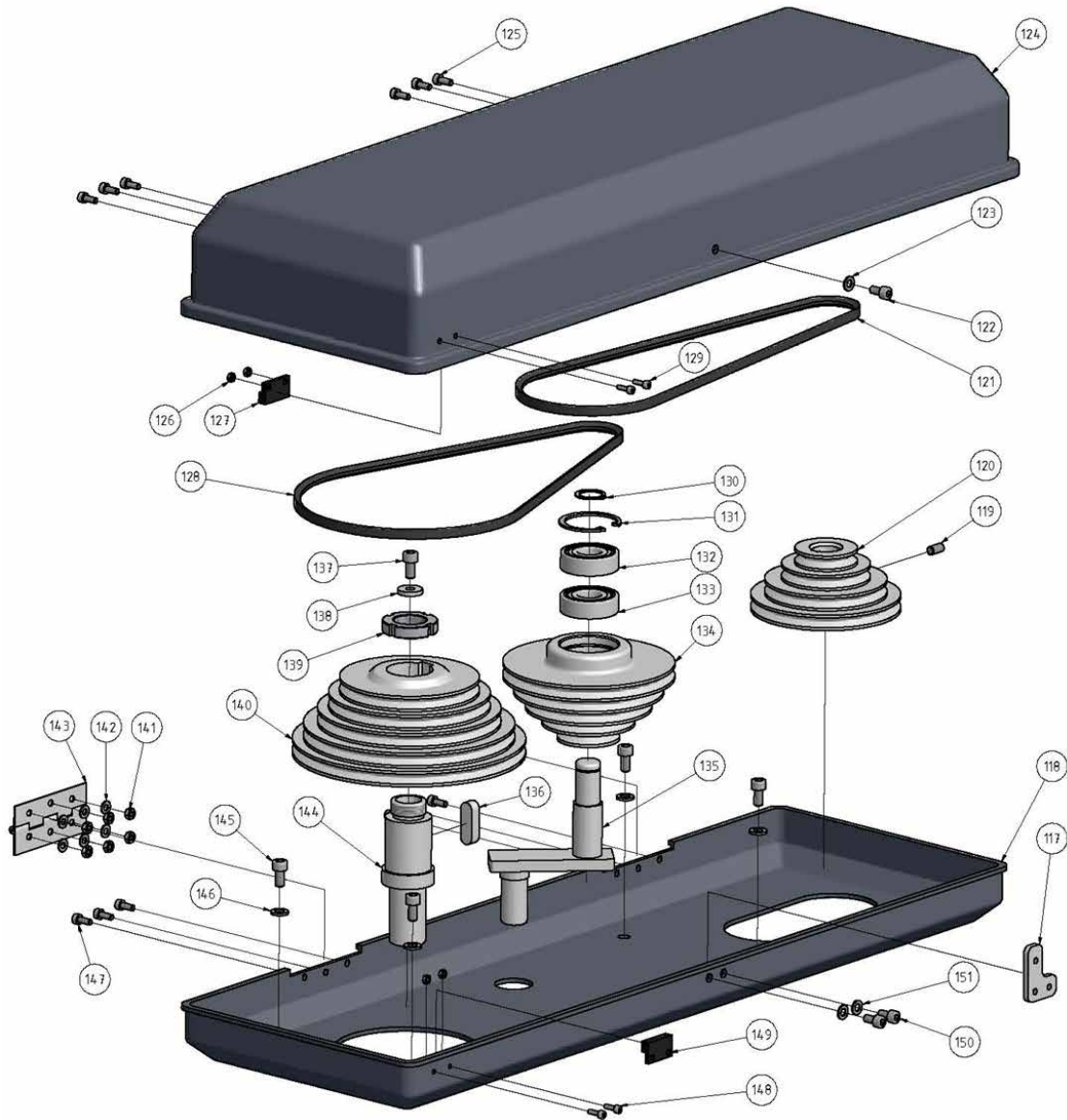

Fig. 7-10: Pulleys B28HV

7.4.2 Parts list B28HV

B28HV				
Pos.	Description	Qty.	Size	Item no.
117	Plate closer	1		03020285117
118	Belt housing base	1		03020285118
119	Threaded pin	1		03020285119
120	Pulley	1		03020285120
121	V-belt	1		03020285121
122	Socket head screw	3	M5x10	03020285122
123	Washer	3	5	03020285123
124	Belt housing upper part	1		03020285124
125	Socket head screw	6	M5x10	03020285125
126	Nut	4	M3	03020285126
127	Counterpart reed contact	1		03020285127
128	V-belt	1		03020285128
129	Socket head screw	4	M3x10	03020285129
130	Circlip	1		03020285130
131	Circlip	1		03020285131
132	Bearing	1	6203	03020285132
133	Bearing	1	6203	03020285133
134	Pulley	1		03020285134
135	Knee piece	1		03020285135
136	Feather key	1		03020285136
137	Socket head screw	1		03020285137
138	Washer	1		03020285138
139	Groove nut	1	M24x1,5	03020285139
140	Pulley	1		03020285140
141	Hexagonal nut	12		03020285141
142	Washer	12		03020285142
143	Articulation	2		03020285143
144	Washer	1		03020285144
145	Socket head screw	4	M6x15	03020285145
146	Washer	4		03020285146
147	Socket head screw	4		03020285147
148	Socket head screw	4		03020285148
149	Reed contact	1	PS-3150	03020285149
150	Socket head screw	3	M5x10	03020285150
151	Washer	2	5	03020285151
155	Washer	1		03020285155
156	Socket head screw	1		03020285156
157	Spindle sleeve feed grip old version	1		03020285157
157-1	Fixture sleeve handle	1		03020283171
157-2	Spindle sleeve handle	3		0302130332
158	Plastic handhold old version	3		03020285158
159	Quick action grip	1		03020285159
160	Clamping screw	1		03020285160
161	Setscrew	1	M8x15	03020285161
162	Cable connection	2		03020285162
163	Scale ring	1		03020285163
164	Knurled screw	1	M8x20	03020285164
165	Bushing quick action grip	1		03020285165
166	Sliding block	1		03020285166
167	Label „spans“ „release“	1		03020285167
168	Socket head screw	2	M3x10	03020285168
169	Hexagonal nut	1		03020285169
170	Bolt	1		03020285170
171	Socket head screw	6	M3x8	03020285171
172	Cover motor	1		03020285172
173	Flange motor	1		03020285173
174	Socket head screw	6	M6x55	03020285174
175	Cover drilling head	1		03020285175
176	Cover	1		03020285176
177	Brushlesscontroller	1		03020285177
177-1	Trafo	1		030202451771
177-2	EMV-Filter	1		030202451772
178	Socket head screw	3	M4x20	03020285178
179	Feather key	1		03020285179
180	Washer	4		03020285180
181	Drilling head	1		03020285181
182	Spacer ring	1		03020285182

B28HV

Pos.	Description	Qty.	Size	Item no.
183	Shaft	1		03020285183
184	Circlip	2	DIN472 47x1.6	03020285184
185	Ball bearing	1	6205-2R	0406205.2R
186	Ball bearing	1	6005	03020285186
187	Circlip	2	DIN472 47x1.6	03020285187
188	Bushing	1		03020285188
189	main switch	1	660V 20A	03020285189
190	Socket head screw	1		03020285190
191	Socket head screw	7	M6x15	03020285191
192	Light switch ON/ OFF	1	250V 6A	03020285192
193	Socket head screw	3		03020285193
194	Covering plate	1		03020285194
195	Circlip	1	DIN471-12x1	03020285195
196	Box	1		03020285196
197	Recuperating spring	1		03020285197
198	Ejector	1		03020285198
199	Spring	1		03020285199
200	Ball	1		03020285200
201	Digital display	1		03020285201
202	Cooling pump switch ON/ OFF	1	250V 6A	03020285202
203	switch for direction of rotation	1		03020285203
204	Switch plate	1		03020285204
205	Potentiometer	1		03020285205
206	Socket head screw	4	M4x10	03020285206
207	emergency -stop switch	1	600V 10A	03020285207
208	Switch ON/OFF	1		03020285208
209	Connector electric supply	1		03020285209
210	Countersunk screw	2	M5x10	03020285210
211	Alu- profile	1	20x20	03020285211
212	Socket head screw	2	M6x30	03020285212
213	Socket head screw	1	M5x10	03020285213
214	Spanner spiral spring	1		03020285214
215	Split pin	2	3x12	03020285215
216	Bushing	1		03020285216
217	Setscrew	1	M6x20	03020285217
218	Hexagon nut	1	M6	03020285218
219	Rotation speed sensor	1		03020285219
220	Holder	1		03020285220
221	Machine illumination	1		03020285221
222	Hexagonal nut	2		03020285222
223	Sliding block	1		03020285223
224	View sealing pane drill chuck protection	1		03020285224
225	Spring	1		03020285225
226	Washer	1		03020285226
227	Ball bearing	1	6206	03020285227
228	Spring pin	1	5x40	03020285228
229	Spindle sleeve	1		03020285229
230	O-ring	1		03020285230
231	Bushing	1		03020285231
232	Ball bearing	1	6004-2Z	03020285232
233	Shank pinion	1		03020285233
234	Spindle nut	1		03020285234
235	Socket head screw	2		03020285235
236	Key	1	8x8x18	03020285236
237	Mechanical indicator scale	1		03020285237
238	Ring	1		03020285238
239	Spring pin	1		03020285239
240	Socket head screw	2	M6x16	03020285240
241	Scale	1		03020285241
242	Straight pin	1	6x40	03020285242
243	Bushing hup scalering	1		03020285243
244	Key	1		03020285244
245	Spindle	1		03020285245
246	Drill chuck	1		3050626
246-1	Drill chuck (year on construction since 12/2009)	1		3050573

B28HV

Pos.	Description	Qty.	Size	Item no.
247	Motor	1	230V 1.5 kW MBL-123HM-300HA-L Hall Sensor 240° 9.5 amps	03020285247
248	Socket head screw	4	M8x25	03020285248
250	Base	1		03020285250
251	Plate coolant reservoir	1		03020285251
252	Washer	1	8	03020285252
253	Socket head screw	1	M8x12	03020285253
254	Coolant hose	1		03020285254
255	Washer	4	GB97.1-85-10	Socket head screw
256	Washer	4	GB93-87-10	03020285256
257	Socket head screw	4	M10x40	03020285257
258	Distance plate	1		03020285258
259	Toothed wheel	1		03020285259
260	Distance plate	1		03020285260
261	Drive screw	1		03020285261
262	Hose clip	2		03020285262
263	Setscrew	1	M8x15	03020285263
264	Toothed rack	1		03020285264
265	Screw	1	JB-T7270.4-1994-2	03020285265
266	Grip	1	JB-T7270.4-1994-1	03020285266
266-1	Grip complete	1	JB-T7270.4-1994	030202852661
267	Distance plate	1		03020285267
268	Threaded pin	1	M6x6	03020285268
269	Crank	1		03020285269
270	Socket head screw	1	M6x20	03020285270
271	Shaft	1		03020285271
272	Oiler	1		03020285272
273	Socket head screw	1	M16x90	03020285273
274	Clamping lever	1		03020285274
275	Washer	1	16	03020285275
276	Clamping screw	1		03020285276
277	Oiler	2		03020285277
278	Setscrew	1	M8x15	03020285278
279	Ring	1		03020285279
280	Drilling machine table	1		03020285280
281	Coolant hose	1		03020285281
282	Holder	1		03020285282
283	Ball valve	1		03020285283
284	Flexible coolant hose	1		03020285284
285	Clamping screw	1	M6x12	03020285285
286	Hexagon socket screw	2	M6x14	03020285286
287	Ring	1		03020285287
288	Socket head screw	4	M8x30	03020285288
289	Plate	1		03020285289
290	Socket head screw	4	M10x25	03020285290
291	Hose clamp	4		03020285291
292	Column	1		03020285292
293	Coolant hose	1		03020285293
294	Hose clip	1		03020285294
295	Socket head screw	1	M6x10	03020285295
296	Washer	1	GB97.1-85-6	03020285296
297	Coolant pump	1		03020285297
298	Circlip	1		03020285298
299	Pump relay	1		03020285299
300	Cable discharge	1		0302024198

7.4.3 Wiring diagram B28H | B28HB - 115V, 60Hz

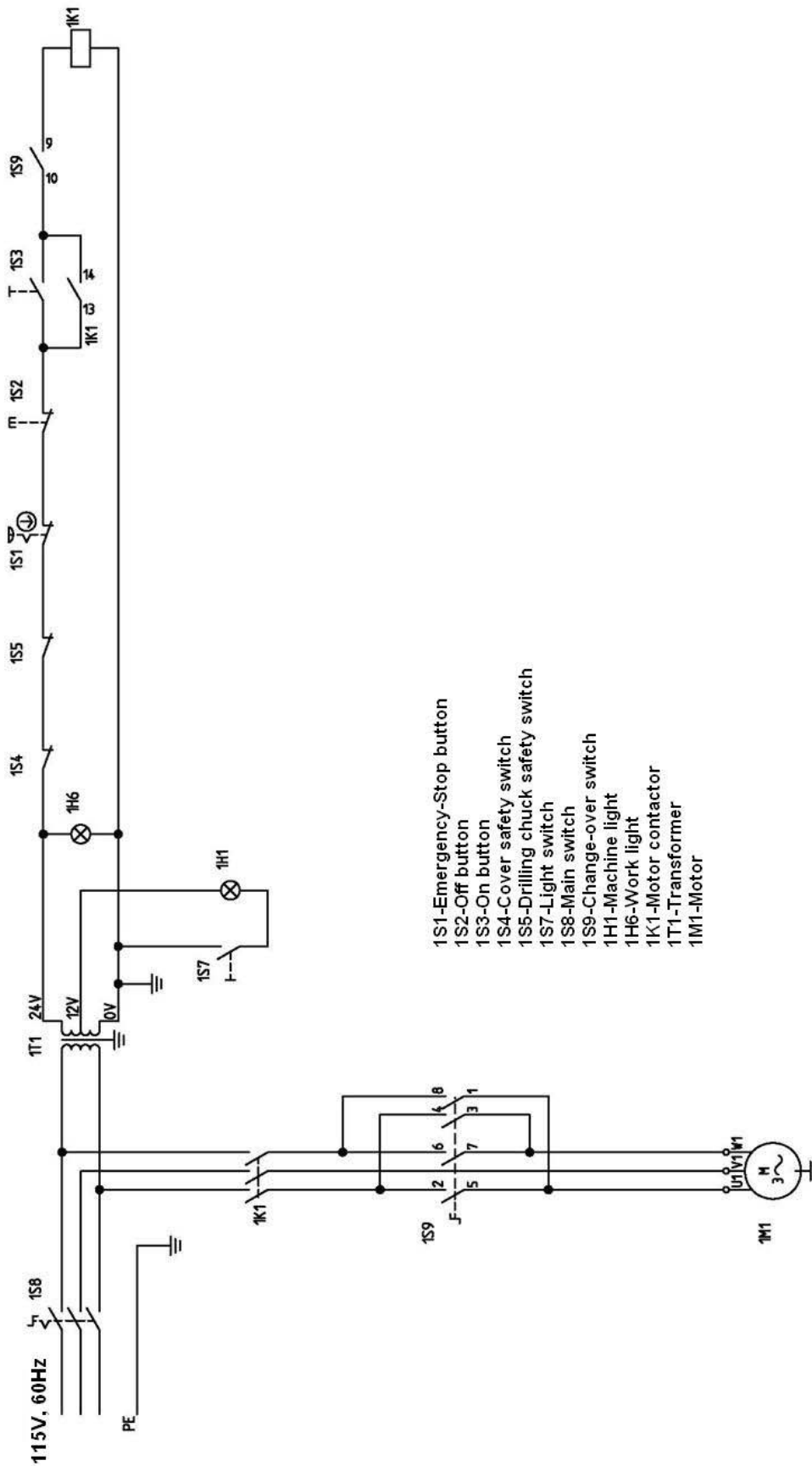

Fig. 7-11: Wiring diagram B28H - 400V

7.4.4 Wiring diagram B28HV, page 1 - 230V, 60Hz

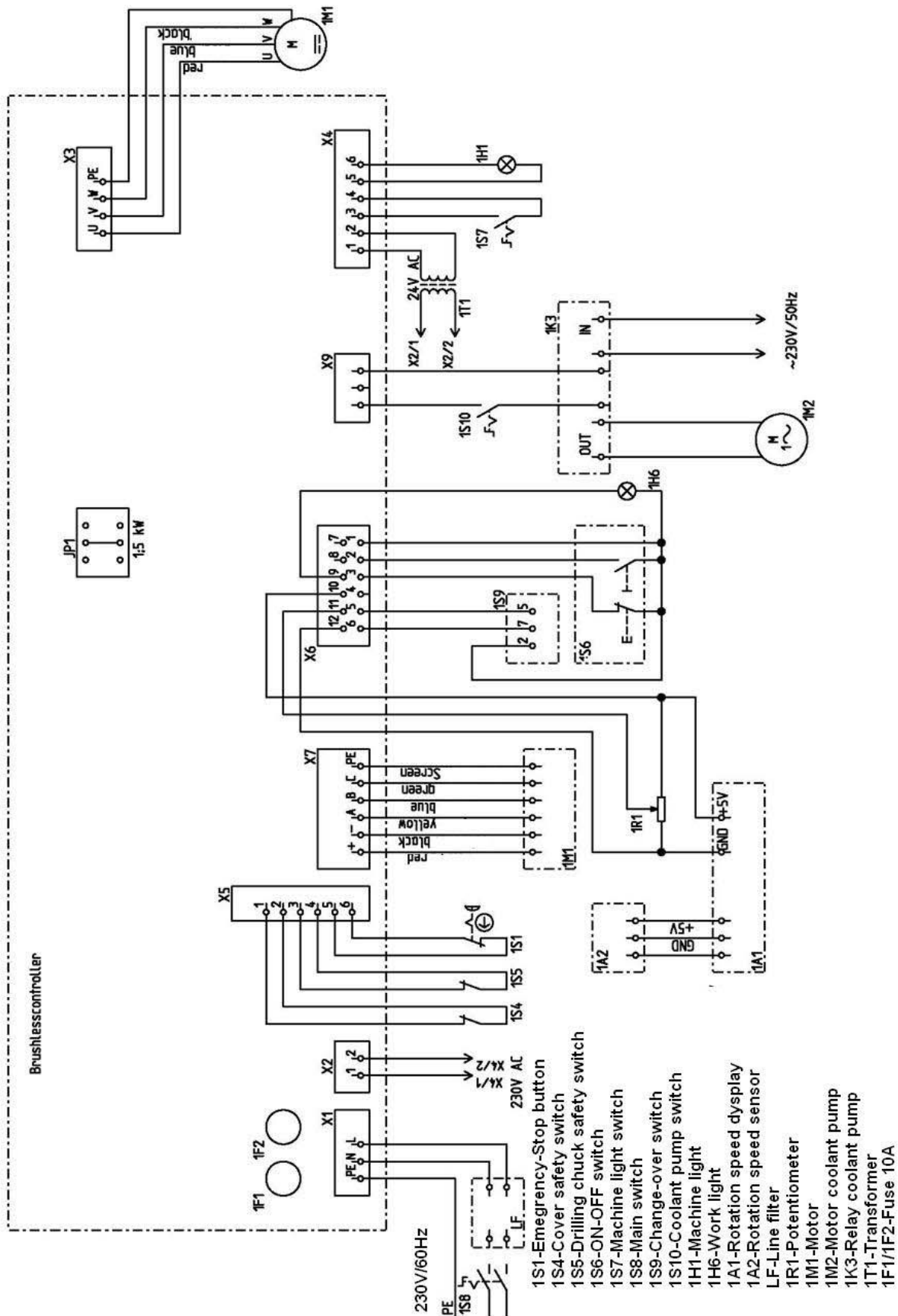

Fig. 7-12: Wiring diagram B28HV

7.4.5 Wiring diagram B28HV, page 2 - 230V, 60Hz

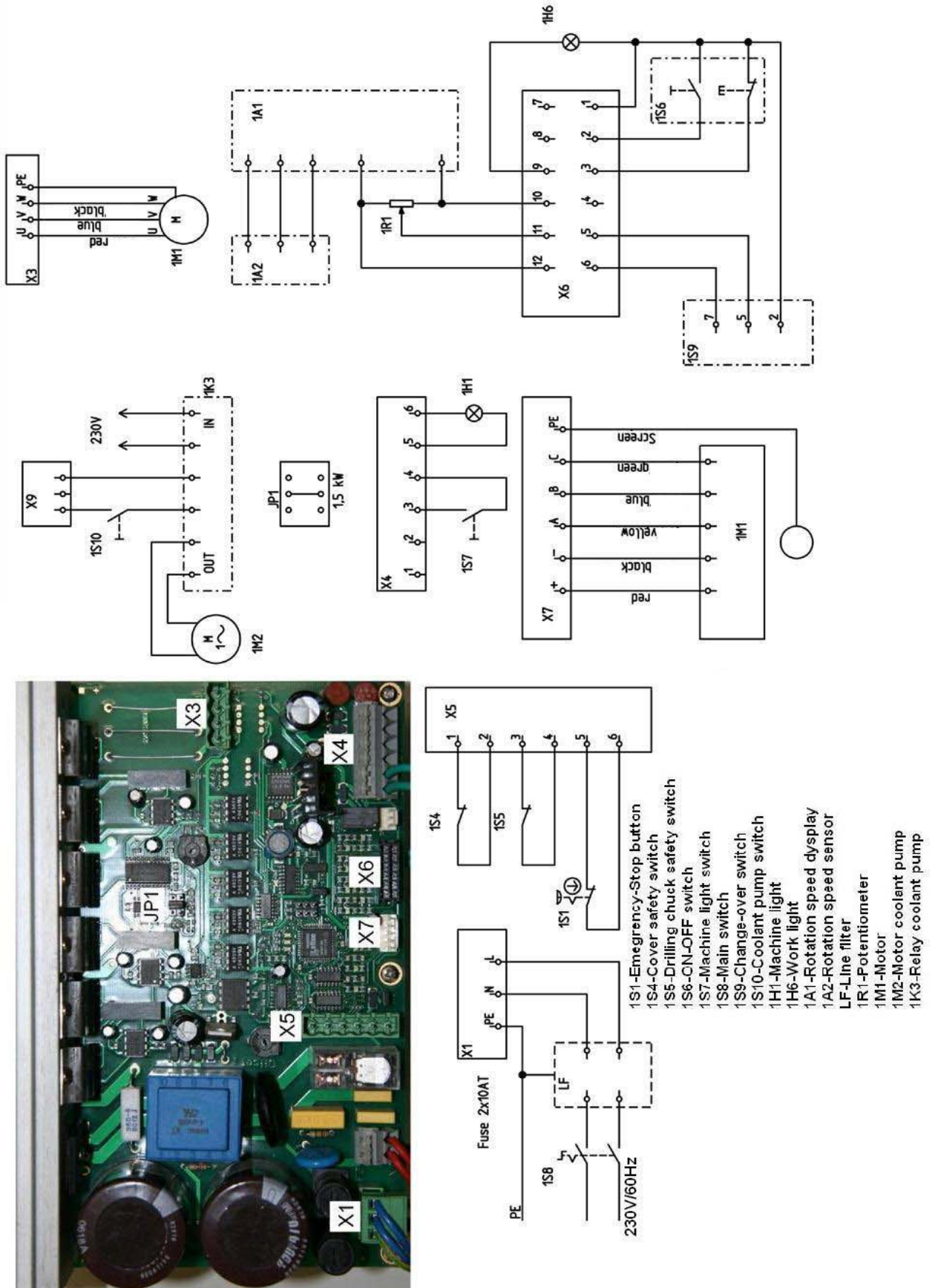



Fig. 7-13: Wiring diagram B28HV

8 Troubleshooting

Problem	Cause / possible effects	Solution
FI protective switch on machines with frequency converter triggers.	<ul style="list-style-type: none"> an unusual FI protective switch is being used 	<ul style="list-style-type: none">  "Power supply" on page 33
Motor gets hot	<ul style="list-style-type: none"> wrong power supply 	
Noise during working	<ul style="list-style-type: none"> Spindle turning dry Tool blunt or is being incorrectly secured 	<ul style="list-style-type: none"> Grease spindle (only in the dismantled condition possible) Use new tool and check securing (fixed setting of the bit, drill chuck and morse taper).
Bit „burnt“	<ul style="list-style-type: none"> bit speed too high/too much feed The chips have not been removed from the bore hole Bit dull no or too little cooling 	<ul style="list-style-type: none"> Select another speed Extract the bit more often Sharpen or replace bit Use coolant.
Bit tip moves, bore hole is not circular	<ul style="list-style-type: none"> hard part on the work piece Unequal length of the cutting spiral or angles in the bit. Bit deformed 	<ul style="list-style-type: none"> Replace bit
Defective bit	<ul style="list-style-type: none"> No support used. 	<ul style="list-style-type: none"> Use a wooden board and secure it to the work piece
Bit running off-centre or „hopping“	<ul style="list-style-type: none"> Bit deformed spindle bearing worn out Bit badly secured. Drill chuck defective. 	<ul style="list-style-type: none"> Replace bit replace spindle bearing Secure the bit properly Replace the drill chuck
Impossible to introduce drill chuck or morse taper	<ul style="list-style-type: none"> There is dirt, grease or oil on the inner conical surface of the drill chuck or on the conical surface of the drill spindle 	<ul style="list-style-type: none"> Clean surfaces well Keep surfaces fat free
Motor does not start	<ul style="list-style-type: none"> motor badly connected Defective fuse 	<ul style="list-style-type: none"> Have it checked by authorized personnel
Overheating of motor and lack of power	<ul style="list-style-type: none"> motor overloaded Insufficient mains voltage motor badly connected 	<ul style="list-style-type: none"> Reduce feed, disconnect if necessary Have it checked by authorized personnel
Precision of the work deficient	<ul style="list-style-type: none"> Heavy and unbalanced or twisted work piece 	<ul style="list-style-type: none"> Balance work piece statically and secure it without straining Adjust work piece holder
Drill spindle does not return to its initial position	<ul style="list-style-type: none"> Failure of spindle return spring Locking bolt inserted 	<ul style="list-style-type: none"> Check spindle return spring and replace if necessary Remove locking bolt
Impossible to move the drill spindle sleeve downwards.	<ul style="list-style-type: none"> Locking bolt inserted Drill depth adjustment no released 	<ul style="list-style-type: none"> Pull out the locking bolt Release drill depth adjustment
Spindle bearings overheating	<ul style="list-style-type: none"> Bearing worn down Excessive prior tension of the bearing Working at high rate for a long time 	<ul style="list-style-type: none"> Replace Reduce bearing slack for fixed bearing (conical-roller bearing) Reduce bit speed/feed

Problem	Cause / possible effects	Solution
Working spindle rattling on rough piece surfaces	<ul style="list-style-type: none"> • Excessive slack in bearing • Working spindle goes up and down • Adjustment strip loose • Chuck loose • Tool blunt • Piece loose 	<ul style="list-style-type: none"> • Reduce bearing slack or replace bearing • Readjust bearing slack (fixed bearing) • Adjust strip to the correct slack using the adjusting screw • Check, re-tighten • Sharpen or replace tool • Secure the piece properly

9 Appendix

9.1 Copyright

This documentation is copyright. All derived rights are also reserved, especially those of translation, re-printing, use of figures, broadcast, reproduction by photo-mechanical or similar means and recording in data processing systems, neither partial nor total.

The company reserves the right to make technical alternations without prior notice.

9.2 Terminology/Glossary

Term	Explanation
Drift	Tool for removing the bit or the drill chuck from the drill spindle
Drill chuck	Fixture for holding the bit
Drill head	Upper part of the bench drill and upright drill
Drill sleeve	Fixed hollow shaft which runs in the drill spindle
Drill spindle	Shaft activated by the motor
Drilling table	Support surface, clamping surface
Keyless drill chuck	Manually tightenable bit holding fixture
Morse taper	Taper of the bit or drill chuck
Spindle lever	Manual control for the drill fee
Tool	Milling cutter, drill bit, countersink, etc.
Workpiece	Piece to be drilled or machined

Index

A		
Accident report	15	
Assembly	23	
Drilling machine table B24H (B28HB)	27	
Drilling machine table B28H (Vario)	27	
C		
Classification of hazards	6	
Copyright	78	
Cutting speeds	46	
D		
Dimensions	20	
Dimensions B24H	19	
Dimensions B28H	21	
Dimensions B28H Vario	22	
Dimensions B28HB	20	
Drill depth stop	41	
Drilling capacity	16	
Drilling machine table	16	
E		
Electrical	15	
EMERGENCY-STOP button	12	
Emissions	17	
Environmental conditions	17	
F		
First use	33	
I		
Inspection	50	
L		
LIMITED WARRANTY	79	
M		
Maintenance	50	
O		
Obligations		
Operator	9	
User	10	
Operating material	17	
Other pictograms	7	
P		
Power connection	16	
Power supply	33	
Proper use	8	
Q		
Qualification of employees	9	
R		
Required space	17	
S		
Safety		
during maintenance	14	
Safety devices	10	
Safety warnings	6	
Scope of delivery	23	
Speed table		
B24H	40	
B28H	41	
B28H (B)	40	
B28HVario	40	
Speeds	17	
Spindle	16	
Storage	24	
T		
Table cutting speeds	46	
Table cutting speeds / infeed	46	
Technical data	16	
Transport	23	
Troubleshooting	76	
W		
Warnings	6	