

PALMGREN®

15" STEP PULLEY FLOOR DRILL PRESS



Read carefully and follow all safety rules and operating instructions before first use of this product.

GETTING STARTED

DESCRIPTION

Palmgren 15" Step Pulley Floor Drill Press features a heavy cast iron base, column collar, work table and head. Work table height is adjustable using rack and pinion. Table can be tilted 45° both right and left, and rotates 360° on a vertical axis. Work table surface is precision ground which features T-slots for secure, accurate mounting of workpiece. Other features of the Palmgren drill press are an enclosed ball bearing quill assembly, quick belt change and tension mechanism, positive quick-adjust feed depth stop and a 1 HP, 1725 RPM motor. A chuck and chuck arbor are included.

Palmgren drill presses are ideal for use in home shops, maintenance shops and light industrial applications. Spindle speeds are adjustable for drilling steel, cast iron, aluminum, wood and plastic.

STRUCTURAL REQUIREMENTS

Make sure all supporting structures and load attaching devices are strong enough to hold your intended loads. If in doubt, consult a qualified structural engineer.

ELECTRICAL REQUIREMENTS

The power supply to the Drill Press needs to be 120 volt/ 10 amp, single phase, 60 Hz. The standard allowable voltage variation is plus or minus 10%.

TOOLS NEEDED:

Standard mechanic's hand tool set.

UNPACKING

WARNING: Be careful not to touch overhead power lines, piping, lighting, etc. if lifting equipment is used. Drill Press weighs approximately 123 lbs, proper tools, equipment and qualified personnel should be employed in all phases of unpacking and installation.

Crates should be handled with care to avoid damage from dropping, bumping, etc. Store and unpack crates with correct side up. After uncrating Drill Press, inspect carefully for any damage that may have occurred during transit. Check for loose, missing or damaged parts. If any damage or loss has occurred, claim must be filed with carrier immediately. Check for completeness. Immediately report missing parts to dealer.

The Drill Press is shipped unassembled. Locate and identify the following assemblies and loose parts: head assembly, base, column assembly, table and quill feed handle assembly.

IMPORTANT: Many unpainted steel surfaces, such as column and table top, have been coated with a protectant. To ensure proper fit and operation, remove coating. Coating is easily removed with mild solvents, such as mineral spirits, and a soft cloth. Avoid getting solution on paint or any of the rubber or plastic parts. Solvents may deteriorate these finishes. Use soap and water on paint, plastic or rubber components. After cleaning, cover all exposed surfaces with a light coating of oil. Paste wax is recommended for table top.

CAUTION: Never use highly volatile solvents. Avoid getting cleaning solution on paint as it may tend to deteriorate these finishes. Use soap and water on painted components.

CONTENTS:

- Drill Press (1)
- Head assembly (1)

- Base (1)
- Column assembly (1)
- Table (1)
- Quill feed handle assembly (1)
- Hardware bag (1) includes: Drill chuck with key, arbor, drill drift, table crank handle assembly, head assembly with motor, 3 and 4mm hex wrenches, four M8 × 30 hex bolts and four 8mm lock washers and hex nuts for column.
- Operating Instructions and Parts Manual (1)

UNPACK:

Unbolt saw from pallet and carefully lift saw from pallet using appropriate hoisting equipment. Do not discard packing materials until after machine has been inspected for damage and completeness. Locate loose parts and set aside.

INSPECT:

After unpacking the unit, carefully inspect for any damage that may have occurred during transit. Check for loose, missing or damaged parts. Shipping damage claims must be filed with the carrier.

All tools should be visually inspected before use, in addition to regular periodic maintenance inspections.

Be sure that the voltage labeled on the unit matches your power supply.

SAFETY RULES

WARNING: For your own safety, read all of the instructions and precautions before operating tool.

PROPOSITION 65 WARNING: Some dust created by using power tools contain chemicals known to the state of California to cause cancer, birth defects or other reproductive harm.

Some examples of these chemicals are:

- Lead from lead-based paints.
- Crystalline silica from bricks and cement and other masonry products.
- Arsenic and chromium from chemically-treated lumber.

Your risk from these exposures varies, depending on how often you do this type of work. To reduce your exposure to these chemicals: work in a well ventilated area and work with approved safety equipment. Always wear **OSHA/NIOSH** approved, properly fitting face mask or respirator when using such tools.

WARNING: Always follow proper operating procedures as defined in this manual even if you are familiar with the use of this or similar tools. Remember that being careless for even a fraction of a second can result in severe personal injury.

BE PREPARED FOR JOB

- Wear proper apparel. Do not wear loose clothing, gloves, neckties, rings, bracelets or other jewelry which may get caught in moving parts of machine.
- Wear protective hair covering to contain long hair.
- Wear safety shoes with non-slip soles.
- Wear safety glasses complying with United States ANSI Z87.1. Everyday glasses have only impact resistant lenses. They are **NOT** safety glasses.
- Wear face mask or dust mask if operation is dusty.
- Be alert and think clearly. Never operate power tools when tired, intoxicated or when taking medications that cause drowsiness.

SAFETY RULES (CONTINUED)

PREPARE WORK AREA FOR JOB

- Keep work area clean. Cluttered work areas invite accidents.
- Do not use power tools in dangerous environments. Do not use power tools in damp or wet locations. Do not expose power tools to rain.
- Work area should be properly lighted.
- Proper electrical receptacle should be available for tool. Three-prong plug should be plugged directly into properly grounded, three-prong receptacle.
- Extension cords should have a grounding prong and the three wires of the extension cord should be of the correct gauge.
- Keep visitors at a safe distance from work area.
- Keep children out of workplace. Make workshop childproof. Use padlocks, master switches or remove switch keys to prevent any unintentional use of power tools.

TOOL SHOULD BE MAINTAINED

- Always unplug tool prior to inspection.
- Consult manual for specific maintaining and adjusting procedures.
- Keep tool lubricated and clean for safest operation.
- Remove adjusting tools. Form habit of checking to see that adjusting tools are removed before switching machine on.
- Keep all parts in working order. Check to determine that the guard or other parts will operate properly and perform their intended function.
- Check for damaged parts. Check for alignment of moving parts, binding, breakage, mounting and any other condition that may affect a tool's operation.
- A guard or other part that is damaged should be properly repaired or replaced. Do not perform makeshift repairs. (Use parts list provided to order repair parts.)

KNOW HOW TO USE TOOL

- Use right tool for job. Do not force tool or attachment to do a job for which it was not designed.
- Disconnect tool when changing the blade.
- Avoid accidental start-up. Make sure that the tool is in the OFF position before plugging in.
- Do not force tool. It will work most efficiently at the rate for which it was designed.
- Keep hands away from moving parts and cutting surfaces.
- Never leave tool running unattended. Turn the power off and do not leave tool until it comes to a complete stop.
- Do not overreach. Keep proper footing and balance.
- Never stand on tool. Serious injury could occur if tool is tipped or if blade is unintentionally contacted.
- Know your tool. Learn the tool's operation, application and specific limitations.
- Use recommended accessories. Use of improper accessories may cause risk of injury to persons.
- Handle workpiece correctly. Protect hands from possible injury.
- Turn machine off if it jams. Drill bit jams when it digs too deeply into workpiece. (Motor force keeps it stuck in the work.) Do not remove jammed or cut off pieces until the saw is turned off, unplugged and the blade has stopped.
- All work shall be secured using either clamps or a vise to the drill press table. It is unsafe to use your hands to hold any workpiece being drilled.

- Feed work into a bit or cutter against the direction of rotation of bit or cutter.
- Use recommended speed for drill accessory and workpiece material.
- Keep guards in place and in proper working order. Do not operate the machine with guards removed.
- Always be sure the machine is securely anchored to the floor or the workbench.
- Make certain table locks and head locks are tightened before starting machine.

CAUTION: Think safety! Safety is a combination of operator common sense and alertness at all times when tool is being used.

SPECIFICATIONS

Chuck size	3-16mm, JT-3
Spindle taper	MT2
Spindle travel	3.15"
Quill diameter	1.58"
Quill collar diameter	52mm
Column diameter	2.75"
Speeds	16
RPM	240–3200
Swing	15"
Table working surface	11.8" × 11.8"
T-slots	5/8"
Base size	17 × 10.5"
Base working surface	8 × 7 ⁵ / ₈ "
Drilling capacity (cast iron)	5/8"
Distance, spindle to table	3/4"–30 ¹ / ₄ "
Distance, spindle to base	47 ³ / ₄ "
Overall height	62 ³ / ₄ "
Shipping Weight	136 lbs
Motor	1 HP, 1725 RPM, 120V, 6.5A, 60 Hz

ASSEMBLY

CAUTION: Do not attempt assembly if parts are missing. Use this manual to order repair parts.

ASSEMBLY OF COLUMN AND TABLE HARDWARE

Refer to Figures 1, 2 and 3.

1. Position base on floor. Remove protective covering and discard.
2. Remove protective sleeve from column tube and discard. Place column assembly on base, and align holes in column support with holes in base.
3. Locate four 3/8" dia. × 9/16" long bolts in loose parts bag.
4. Install a bolt in each hole through column support and base and tighten with adjustable wrench.
5. Locate table crank and support lock in loose parts box.
6. Install support lock from left side into table support and tighten by hand.
7. Install table crank assembly and tighten set screw with a 7/64" HEX "L" wrench. Do not over-tighten. Set screw should be tightened against the flat section of the shaft.

ASSEMBLY (CONTINUED)

NOTE: To minimize crank backlash, tighten support lock, rotate elevation worm shaft clockwise, then assemble crank tight against table support and tighten set screw.

8. Check column collar for proper adjustment. Collar should not be angled on the column and it should not be positioned so rack will slide freely in collar when table is rotated 360° around column table. If re-adjusted, only tighten set screw enough to keep collar in place.

NOTE: To avoid column or collar damage, do not over-tighten set screw.

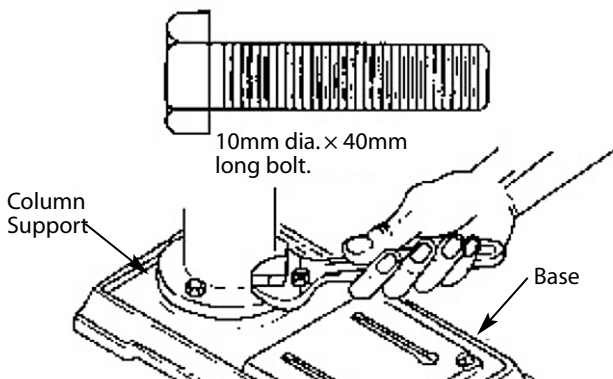

Figure 1 - Install column to base.

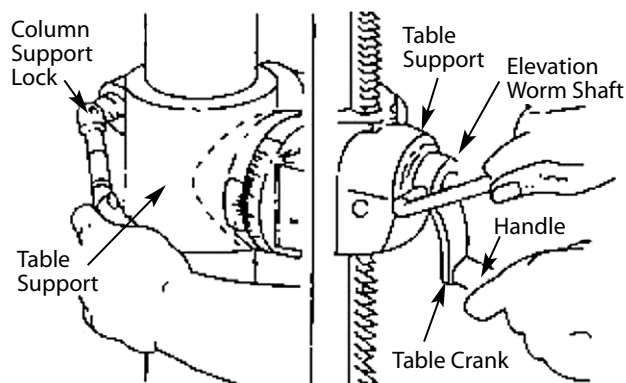

Figure 2 - Install support lock and table crank.

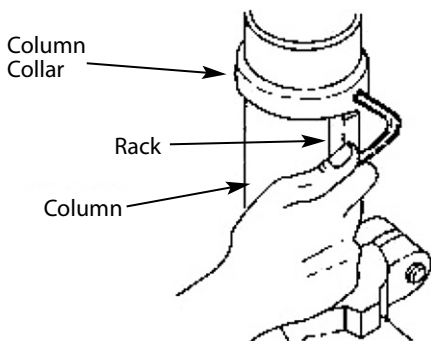

Figure 3 - Tighten column collar's set screw.

INSTALLING THE TABLE

Refer to Figures 4 and 5.

1. Loosen support lock and raise table support by turning table crank clockwise until support is at a working height level. Tighten support lock.
2. Remove protective covering from table and discard. Place table in table support and tighten table lock (located under table) by hand.

NOTE: If table won't fit into table support easily, try opening table support with a flat blade screwdriver. Installing the head

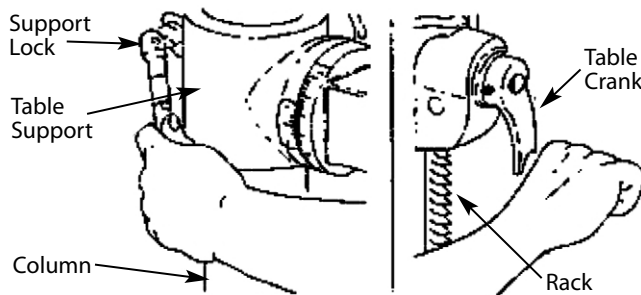

Figure 4 - Loosen support lock and raise table support.

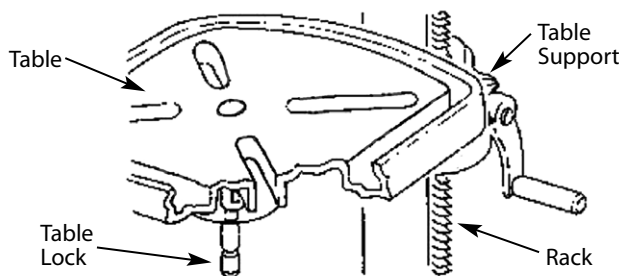

Figure 5 - Installing the table.

INSTALLING THE HEAD

Refer to Figures 6 and 7, pages 4 and 5.

CAUTION: The head assembly weights about 55 pounds. Carefully lift head.

1. Remove protective bag from head assembly and discard. Carefully lift head above column tube and slide it onto column making sure head slides down over column as far as possible. Align head with table and base.
2. Locate two 3/8" dia. x 1/2" long set screws (see illustration) in loose parts bag.
3. Install a set screw in each hole (as indicated) on the right side of the head, and using a 5mm hex "L" wrench, tighten the two head locket screws.

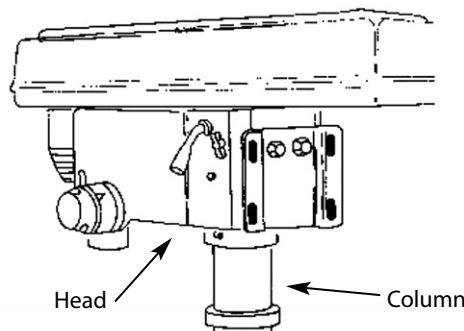

Figure 6 - Install head on column.

ASSEMBLY (CONTINUED)

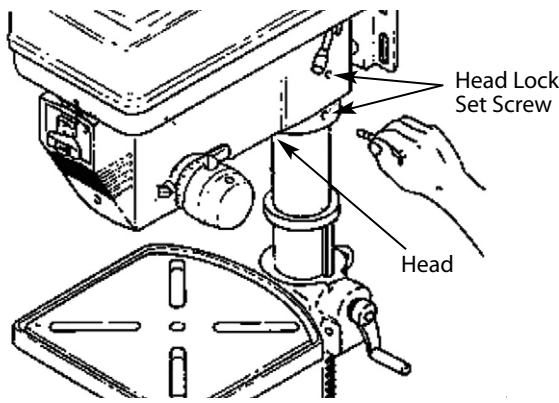

Figure 7 - Install set screws.

INSTALLING THE PULLEY-CENTER

Refer to Figure 8.

Locate center pulley assembly in loose parts bag and place in proper hole.

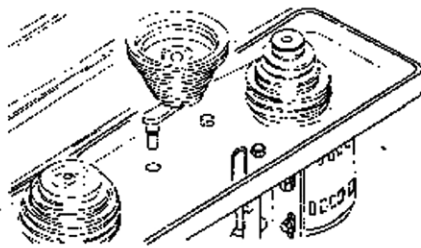

Figure 8 - Install pulley-center.

INSTALLING THE BELT

Refer to Figure 9.

1. Locate two V-belts in the loose parts bag.
2. Use speed chart inside belt guard to choose speed for drilling operation. Install belts in correct position for desired speed. The longer of the two belts is always positioned between the spindle pulley and idler pulley.

NOTE: Refer to inside belt guard for recommended drilling speeds.

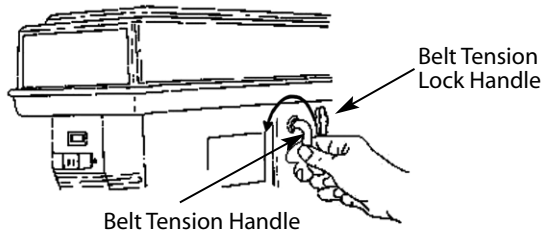
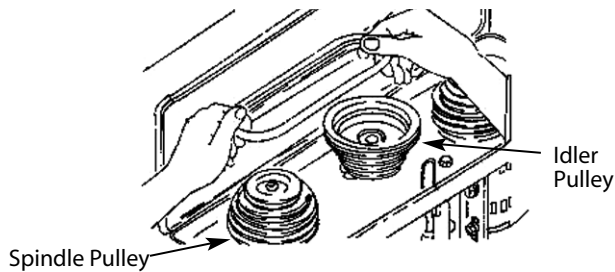

Figure 9 - Installing the belt.

3. Apply tension to belt by turning belt tension handle counter clockwise until belt deflects approximately 1/2" by thumb pressure at its center.

4. Tighten belt tension lock handles.

NOTE: Over-tensioning belt may cause motor not to start or damage bearings.

5. If belt slips while drilling, re-adjust belt tension.

INSTALLING THE BELT GUARD KNOB

Refer to Figure 10.

To attach belt guard knob, locate knob and 5mm dia. x 12mm long pan screw in loose parts bag. Install screw in hole located on guard and attach knob turning until tight.

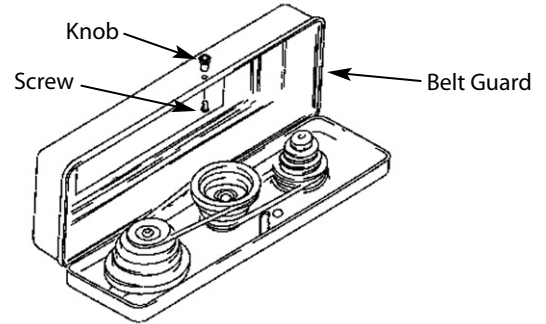

Figure 10 - Install belt guard knob.

INSTALLING FEED HANDLES

Refer to Figure 11.

1. Locate three feed handles among loose parts.
2. Screw the feed handles into the threaded holes in the hub and tighten.

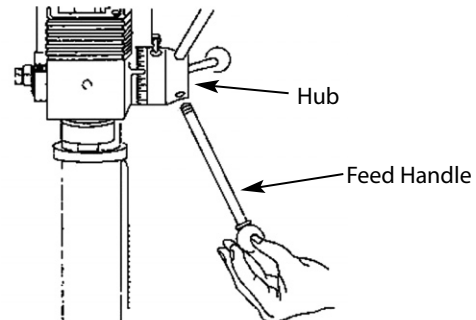

Figure 11 - Install feed handles.

INSTALLING THE CHUCK

Refer to Figures 12 and 13.

1. Clean out the tapered hole in the chuck. Clean the tapered surface on the arbor with a clean cloth. Make sure there are no foreign particles sticking to the surfaces. The slightest piece of the dirt on any of these surfaces will prevent the chuck from seating properly. This will cause the drill to "wobble".
2. Slide the chuck up over the arbor as illustrated.

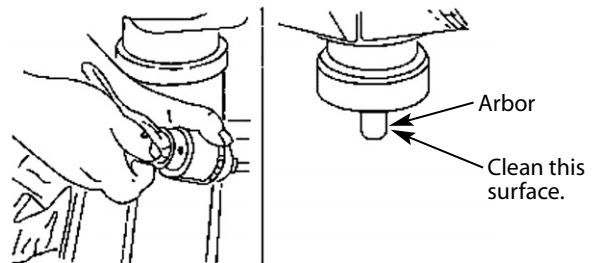

Figure 12 - Clean the tapered hole in the chuck.

ASSEMBLY (CONTINUED)

3. Unlock support lock and raise table so it's about two inches below tip of chuck.
4. Turn chuck sleeve clockwise and open jaws in chuck completely.
5. Turn feed handles counter-clockwise and force chuck against table until chuck is secure.

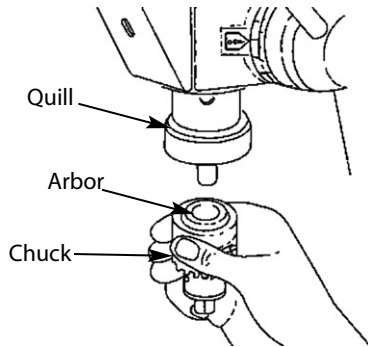

Figure 13 - Slide chuck over arbor.

INSTALLATION

POWER SOURCE

The motor is designed for operation on the voltage and frequency specified. Normal loads will be handled safely on voltages not more than 10% above or below the specified voltage.

Running the unit on voltages which are not within the range may cause overheating and motor burn-out. Heavy loads require that the voltage at motor terminals be no less than the voltage specified.

GROUNDING INSTRUCTIONS

WARNING: Improper connection of equipment grounding conductor can result in the risk of electrical shock. Equipment should be grounded while in use to protect operator from electrical shock.

Check with a qualified electrician if grounding instructions are not understood or if in doubt as to whether the tool is properly grounded.

This tool is equipped with an approved 3-conductor cord rated at 300V and a 3-prong grounding type plug (See Figure 14) for your protection against shock hazards.

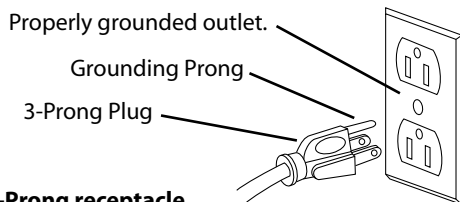

Figure 14 – 3-Prong receptacle.

Grounding plug should be plugged directly into a properly installed and grounded 3-prong grounding-type receptacle, as shown in Figure 14.

Do not remove or alter grounding prong in any manner. In the event of a malfunction or breakdown, grounding provides a path of least resistance for electrical shock.

WARNING: Do not permit fingers to touch the terminals of plug when installing or removing from outlet.

Plug must be plugged into matching outlet that is properly installed and grounded in accordance with all local codes and ordinances. Do not modify plug provided. If it will not fit in outlet, have proper outlet installed by a qualified electrician.

Inspect tool cords periodically, and if damaged, have repaired by an authorized service facility.

Green (or green and yellow) conductor in cord is the grounding wire. If repair or replacement of the electric cord or plug is necessary, do not connect the green (or green and yellow) wire to a live terminal.

Where a 2-prong wall receptacle is encountered, it must be replaced with a properly grounded 3-prong receptacle installed in accordance with National Electric Code and local codes and ordinances.

WARNING: This work should be performed by a qualified electrician.

A temporary 3-prong to 2-prong grounding adapter (See Figure 15) is available for connecting plugs to a two pole outlet if it is properly grounded.

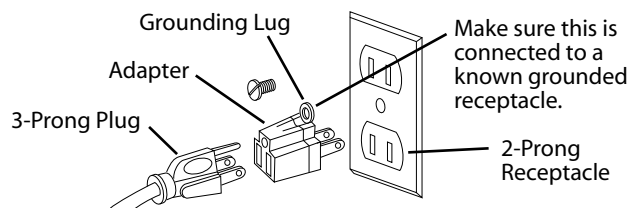

Figure 15 – 2-Prong receptacle with adapter.

Do not use a 3-prong to 2-prong grounding adapter unless permitted by local and national codes and ordinances.

(A 3-prong to 2-prong grounding adapter is not permitted in Canada.) Where permitted, the rigid green tab or terminal on the side of the adapter must be securely connected to a permanent electrical ground such as a properly grounded water pipe, a properly grounded outlet box or a properly grounded wire system.

Many cover plate screws, water pipes and outlet boxes are not properly grounded. To ensure proper ground, grounding means must be tested by a qualified electrician.

EXTENSION CORDS

- The use of any extension cord will cause some drop in voltage and loss of power.
- Wires of the extension cord must be of sufficient size to carry the current and maintain adequate voltage.
- Running the unit on voltages which are not within $\pm 10\%$ of the specified voltage may cause overheating and motor burn-out.
- Use the table to determine the minimum wire size (A.W.G.) extension cord.
- Use only 3-wire extension cords having 3-prong grounding type plugs and 3-pole receptacles which accept the tool plug.
- If the extension cord is worn, cut or damaged in any way, replace it immediately.

Extension Cord Table							
		Volts	Total Length of Cord in Feet				
Ampere Rating		120	25	50	100	150	
		240	50	100	150	300	
		Minimum Gage for Cord					
More Than	Not More Than	0	6	18	16	16	14
6	10	18	16	14	12		
10	12	16	16	14	12		
12	16	14	12	Not Recommended			

INSTALLATION (CONTINUED)**ELECTRICAL CONNECTIONS**

WARNING: All electrical connections must be performed by a qualified electrician.

WARNING: Make sure tool is off and disconnected from power source while motor is mounted, connected, reconnected or any time wiring is inspected.

1. The motor should be wired for 120 volts and clockwise rotation as viewed from shaft end of motor.
2. A label on the motor describes the possible wiring configurations. There are many different possible combinations, so only the diagram provided with the motor should be used.
3. Be sure to install motor cord so that the cover plate for the motor wiring holds the cord in the groove of the motor end shield. The motor cord must be secured to protect the wiring connections from possible strain.
4. The power supply to motor is controlled by a locking rocker switch. Power lines are connected to the quick connect terminals of the switch.
5. The green ground line must remain securely fastened to the

OPERATION

WARNING: Do not attempt to operate tool until it is completely assembled according to the instructions.

ADJUSTING THE TABLE SQUARE TO HEAD

Refer to Figures 16 and 17.

NOTE: The combination square must be "true".

1. Insert a straight ground steel rod or a straight drill bit (not included) approximately 3" long into chuck and tighten.
2. With table raised to working height and locked on column, place combination square flat on table beside rod.
3. If an adjustment is necessary, loosen the set screw under bevel lock with 3mm hex "L" wrench, than loosen the table bevel lock with the 24mm flat wrench (included). (These adjustments are located under the table.)
4. Align the table square to the bit by rotating the table until the square and bit are in line.
5. Retighten table bevel lock.
6. Retighten set screw.

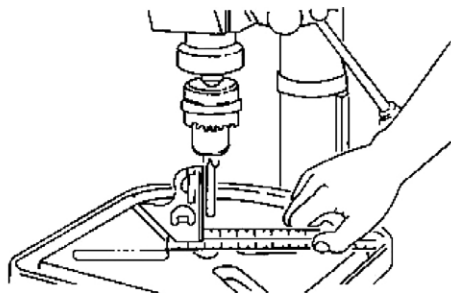

Figure 16 - Check table squareness to head.

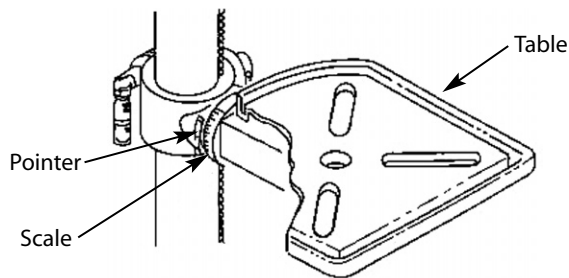

Figure 17

MAINTENANCE

WARNING: Turn switch off and remove plug from outlet before maintaining or lubricating your drill press.

V-BELT

Replace worn V-belt when needed.

LUBRICATION

The ball bearings are lubricated at the factory and need no further lubrication. Using 20 wt. non-detergent oil, periodically lubricate the splines (grooves) in the spindle and the rack (teeth on the quill) as follows:

1. Lower quill and spindle all the way down.
2. Apply lubricant around the inside of the hole in the spindle pulley.
3. Apply lubricant to rack (teeth) on quill while extended below drill press head.
4. Apply lubricant to rack and pinion gear on column and table assembly.
5. Frequently blow out any dust that may accumulate inside the motor. If the power cord is worn, cut, or damaged in any way, have it replaced immediately. For motor lubrication, follow instructions on motor plate.

PULLEY SETTINGS FOR SPINDLE SPEEDS (RPM)

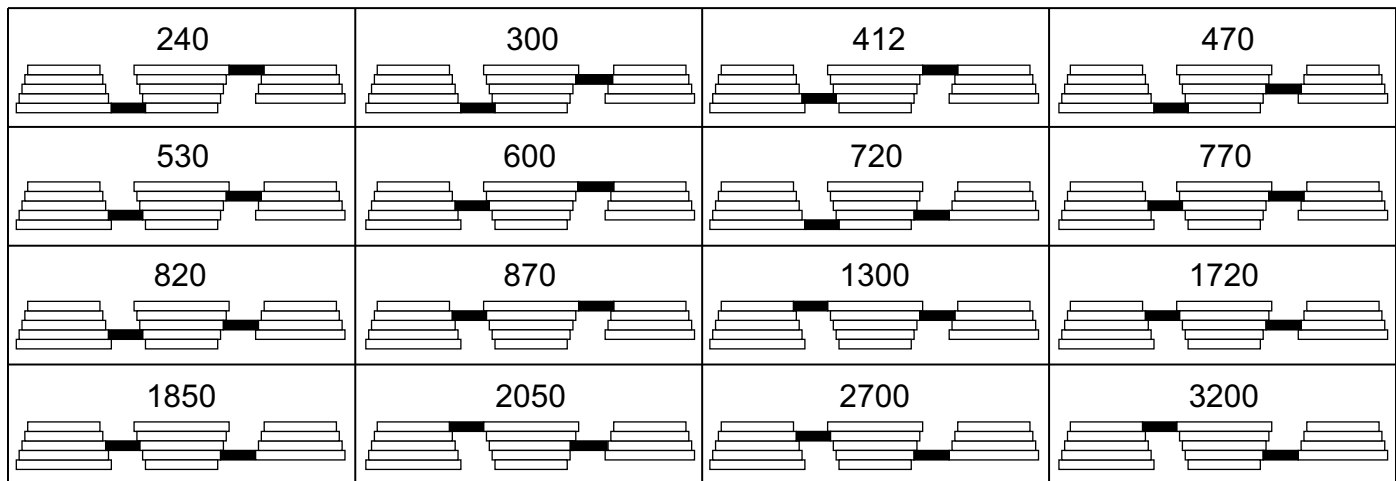

RECOMMENDED SPEED BASED ON MATERIAL AND DRILL BIT SIZE

RPM	Wood		Zinc Diecast		Aluminum & Brass		Plastic		Cast Iron & Bronze		Steel - Mild & Malleable		Steel - Cast & Med. Carbon		Steel - Stainless & Tool	
	in.	mm	in.	mm	in.	mm	in.	mm	in.	mm	in.	mm	in.	mm	in.	mm
3020	5/16	7.9	3/16	4.8	11/64	4.4	5/32	4.0	7/64	2.8	3/32	2.4	1/16	1.6	1/32	0.8
2101	5/8	15.9	3/8	9.5	11/32	8.7	5/16	7.9	1/4	6.4	5/32	4.0	1/8	3.2	1/16	1.6
1699	3/4	19.0	7/16	11.1	13/32	10.3	3/8	9.5	5/16	7.9	3/16	4.8	1/8	3.2	1/16	1.6
1453	7/8	22.2	1/2	12.7	15/32	11.9	7/16	11.1	11/32	8.7	1/4	6.4	3/16	4.8	1/8	3.2
973	1	25.4	5/8	15.9	1/2	12.7	1/2	12.7	3/8	9.5	5/16	7.9	1/4	6.4	3/16	4.8
596	1 1/4	31.8	3/4	19.0	11/16	17.5	5/8	15.9	1/2	12.7	3/8	9.5	5/16	7.9	1/4	6.4
424	1 5/8	41.3	7/8	22.2	3/4	19.0	13/16	20.6	5/8	15.9	1/2	12.7	7/16	11.1	3/8	9.5
309	1 3/4	44.4	15/16	23.8	13/16	20.6	7/8	22.2	3/4	19.0	5/8	15.9	1/2	12.7	7/16	11.1
210	2	50.8	1	25.4	—	—	—	—	—	—	—	—	9/16	14.3	1/2	12.7

TROUBLESHOOTING

SYMPTOM	POSSIBLE CAUSE(S)	CORRECTIVE ACTION
Noisy operation	<ol style="list-style-type: none"> 1. Incorrect belt tension 2. Dry spindle 3. Loose spindle 4. Loose motor pulley 	<ol style="list-style-type: none"> 1. Adjust tension 2. Lubricate spindle (See Lubrication) 3. Tighten pulley nut 4. Tighten set screw in pulley
Bit burns or smokes	<ol style="list-style-type: none"> 1. Incorrect speed 2. Chips not coming out of hole 3. Dull bit 4. Feeding too slow 5. Bit not lubricated 	<ol style="list-style-type: none"> 1. Change speed 2. Retract bit frequently to clear chips 3. Sharpen or replace bit 4. Feed faster; enough to allow drill to cut 5. Lubricate bit
Excessive drill runout or wobble	<ol style="list-style-type: none"> 1. Bent bit 2. Bit not properly installed in chuck 3. Chuck not properly installed 4. Worn spindle bearings 	<ol style="list-style-type: none"> 1. Replace bit 2. Install bit properly 3. Install chuck properly 4. Replace bearings
Drill bit binds in workpiece	<ol style="list-style-type: none"> 1. Workpiece pinching bit or excessive feed pressure 2. Improper belt tension 3. Workpiece not supported or clamped properly 	<ol style="list-style-type: none"> 1. Support or clamp work, decrease feed pressure 2. Adjust tension 3. Support or clamp workpiece securely

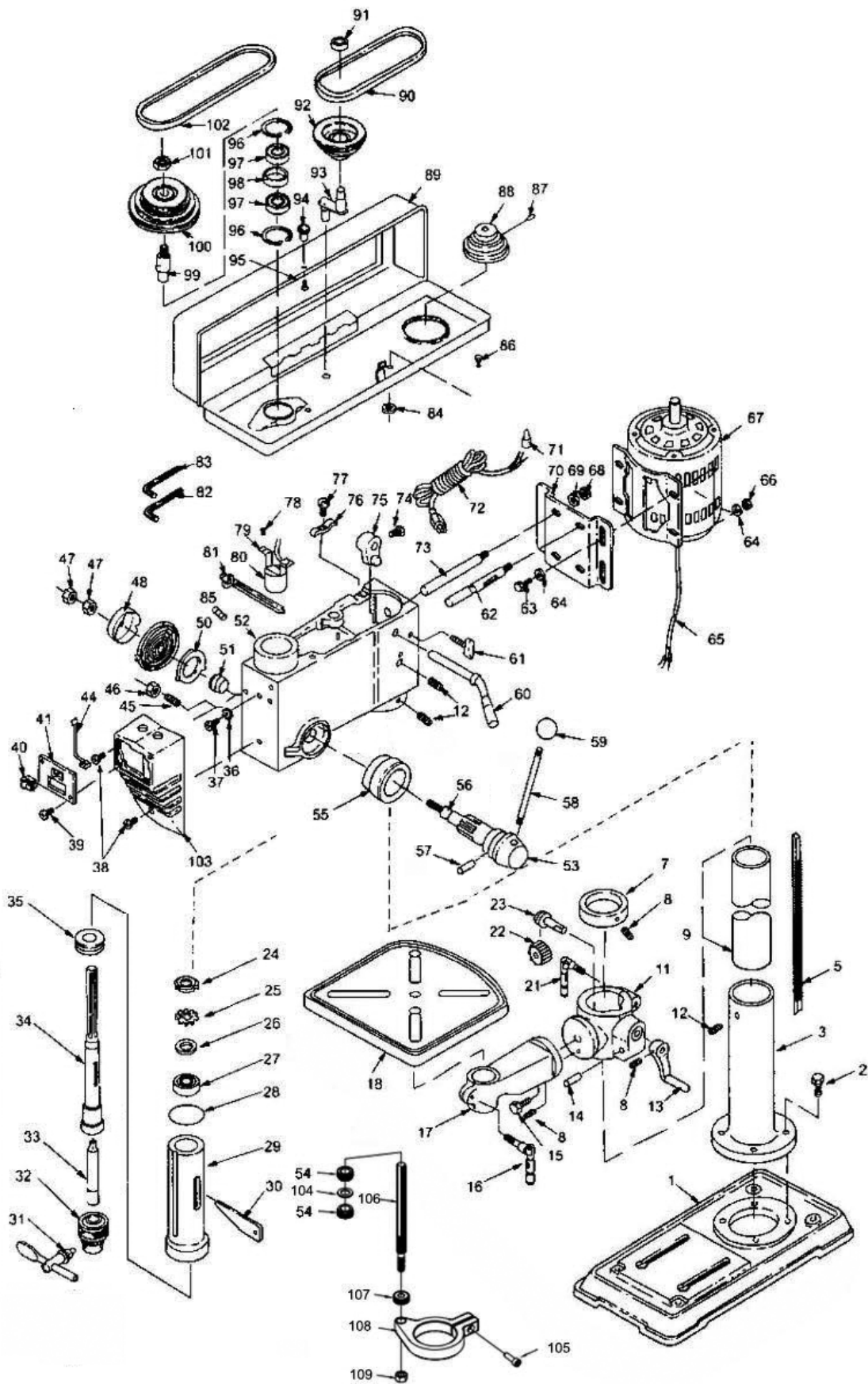

Figure 18 – Replacement Parts Illustration for 15" Step Pulley Floor Drill Press

REPLACEMENT PARTS LIST FOR 15" STEP PULLEY FLOOR DRILL PRESS

Ref. No.	Description	Part No.	Qty.	Ref. No.	Description	Part No.	Qty.
1	Base	964300701	1	59	Knob	964303901	1
2	Hex head screw	*	1	60	Belt tension handle	964304001	1
3	Support column	964300801	1	61	Motor adjustment knob	964304101	1
5	Rack	964300901	1	62	Motor support	964304201	1
7	Collar-rack	964301001	1	63	Hex head screw	*	1
8	Hex head screw	*	1	64	Washer	*	1
9	Tube column	964301101	1	65	Motion cord	964304301	1
11	Table support	964301201	1	66	Hex nut	*	1
12	Hex head screw	*	1	67	Motor	964304401	1
13	Crank	964301301	1	68	Hex nut	*	1
14	Pin-gear	964301401	1	69	Lock washer	*	1
15	Hex head screw	*	1	70	Motor mount	964304501	1
16	Table clamp	964301501	1	71	Wire connector	*	1
17	Table arm	964301601	1	72	Power cord	964304601	1
18	Square table	964301701	1	73	Motor support	964304701	1
21	Clamp column	964301801	1	74	Hex head screw	*	1
22	Gear helical	964301901	1	75	Cam	964304801	1
23	Worm	964302001	1	76	Line cord clamp	*	1
24	Lock nut	964302101	1	77	Pan head screw	*	1
25	Locking ring	964302201	1	78	Set screw	*	1
26	Washer	*	1	79	Clamp	964304901	1
27	Ball bearing	*	1	80	Lamp socket	964305001	1
28	Quill gasket	964302301	1	82	Allen wrench 7/64"	*	1
29	Quill tube	964302401	1	83	Allen wrench	*	1
30	Drift key	964302501	1	84	Hex nut	*	1
31	Chuck key	963053500	1	85	Set screw	*	1
32	Chuck JT3 16MM	963053600	1	86	Cap screw	*	1
33	Arbor MT2	961890800	1	87	Set screw	*	1
34	Spindle	964302601	1	88	Motor pulley	964305101	1
35	Ball bearing	964302701	1	89	Pulley housing	964305201	1
36	Lock washer	*	1	90	Rear V-belt	964305301	1
37	Screw	*	1	91	Bearing	*	1
38	Screw	*	1	92	Center pulley	964305401	1
39	Pan head screw	*	1	93	Transmitting shaft	964305501	1
40	Switch w/Key	961608000	1	94	Knob	964305601	1
41	Switch plate cover	964302801	1	95	Pan head screw	*	1
44	Lead	964302901		96	Snap ring	964305701	2
45	Set screw	*	1	97	Bearing	*	2
46	Hex nut	*	1	98	Spacer	964305801	1
47	Hex nut	*	1	99	Spindle sleeve	964305901	1
48	Cap & spring assembly	964303001	1	100	Spindle pulley	964306001	1
50	Retaining spring	964303101	1	101	Spindle nut	964306101	1
51	Seat spring	964303201	1	102	Front V-belt	964306201	1
52	Head	N/A	1	103	Switch housing	964306301	1
53	Handle seat	964303301	1	104	Lock washer with	964853201	1
54	Adjusting nut	964303401	2	105	Screw Pan GB70-85	964853301	1
55	Spacer	964303501	1	106	Adjust the screw	964853401	1
56	Pinion shaft	964303601	1	107	Lock nut	964853501	1
57	Elastic cylindrical pin/5×16	964303701	1	108	Clamping hoop	964853601	1
58	Rod	964303801	1	109	Nut-Hex GB6170-86	964853701	1

(Δ) Not shown.

(N/A) Not available as repair part.

(*) Standard hardware item, available locally.

PALMGREN WARRANTY

C.H. Hanson / Palmgren warrants their products to be free of defects in material or workmanship. This warranty does not cover defects due directly or indirectly to misuse, abuse, normal wear and tear, failure to properly maintain the product, heated, ground or otherwise altered, or used for a purpose other than that for which it was intended.

The warranty does not cover expendable and/or wear part (i.e. v-belts, screws, abrasives, jaws), damage to tools arising from alteration, abuse or use other than their intended purpose, packing and freight. The duration of this warranty is expressly limited to the terms noted below beginning from the date of delivery to the original user.

The Palmgren branded items carry the following warranties on parts:

All arbor presses, vises, clamps, positioning tables, tombstones, jack screws and vise accessories - LIFETIME.

All bench grinders, drill presses, tapping machines, band saws, lathes, milling machines, abrasive finishing machines and work stands - 3 YEARS.

The obligation of C.H. Hanson / Palmgren is limited solely to the repair or replacement, at our option, at its factory or authorized repair agent of any part that should prove inoperable. Purchaser must lubricate and maintain the product under normal operating conditions at all times. Prior to operation become familiar with product and the included materials, i.e. warnings, cautions and manuals.

Failure to follow these instructions will void the warranty.

This warranty is the purchaser's exclusive remedy against C.H. Hanson for any inoperable parts in its product. Under no circumstances is C.H. Hanson liable for any direct, indirect, incidental, special or consequential damages including loss of profits in any way related to the use or inability to use our products. This warranty gives you specific legal rights which may vary from state to state.

PALMGREN®

Palmgren - a C.H. Hanson Company
2000 N. Aurora Rd., Naperville, IL 60563 U.S.A.
or call 1-800-827-3398