

# PALMGREN®

## 8" DRILL PRESS



***Read carefully and follow all safety rules and operating instructions before first use of this product.***

## GETTING STARTED

### SAVE THIS MANUAL

You will need the manual for the safety warnings and precautions, assembly instructions, operating and maintenance procedures, parts list and diagram. Keep your invoice with this manual. Write the invoice number on the inside of the front cover. Keep this Manual and invoice in a safe and dry place for future reference.

### STRUCTURAL REQUIREMENTS

Ensure all supporting structures and load attaching devices are strong enough to hold the intended loads. If in doubt, consult a qualified structural engineer.

### ELECTRICAL REQUIREMENTS

The power supply to the 8" Bench Model Drill Press needs to be 120 volts, single phase, 60 Hz. The standard allowable voltage variation is plus or minus 10%.

### TOOLS NEEDED:

Standard mechanic's hand tool set (i.e. hammer, screwdrivers, adjustable wrenches, etc.).

## UNPACKING

When unpacking, check to make sure all parts listed below are included. If any parts are missing or broken, please contact your local retailer.

**IMPORTANT:** Many unpainted steel surfaces, such as the column and table top, have been coated with a protectant. To ensure proper fit and operation, remove coating. Coating can be easily removed with mild solvents, such as mineral spirits, and a soft cloth. Avoid getting solution on paint or any of the rubber/ plastic parts. Solvents may deteriorate these finishes. Use soap and water on paint, plastic or rubber components. After cleaning, cover all exposed surfaces with a light coating of oil. Paste wax is recommended for table top.

**CAUTION:** Never use highly volatile solvents. Nonflammable solvents are recommended to avoid possible fire hazard.

### CONTENTS:

- Head assembly/motor (1)
- Base (1)
- Column (1)
- Table assembly (1)
- Handles (3)
- Chuck/chuck key (1)
- Table lock handle (1)
- 3mm hex-wrench (1)
- 4mm hex-wrench (1)
- Operating Manual & Parts List (1)

### UNPACK

Open carton and carefully remove the top Styrofoam section, containing the base, table assembly, chuck box, and hardware bag. Then remove the head assembly and column from the lower Styrofoam section. Do not discard packing materials until after the machine has been inspected for damage and completeness. Locate loose parts and set aside.

### INSPECT

After unpacking the unit, carefully inspect for any damage that may have occurred during transit. Check for loose, missing, or damaged parts. Shipping damage claims must be filed with the carrier. All tools should be visually inspected before use, in addition to regular periodic maintenance inspections. Be sure that the voltage labeled on the unit matches your power supply.

## SAFETY RULES

**WARNING:** For your own safety, read all of the instructions and precautions before operating the tool.

**PROPOSITION 65 WARNING:** Some dust created by using power tools contain chemicals known to the state of California to cause cancer, birth defects or other reproductive harm. Some Examples of these chemicals are:

- Lead from lead-based paints
- Crystalline silica from bricks and cement and other masonry products
- Arsenic and chromium from chemically-treated lumber

Your risk from these exposures varies, depending on how often you do this type of work. To reduce your exposure to these chemicals: work in a well ventilated area and work with approved safety equipment. Always wear **OSHA/NIOSH** approved, properly fitting face mask or respirator when using such tools.

**WARNING:** When using the tool, basic safety precautions should always be followed to reduce the risk of personal injury and damage to equipment.

### READ ALL INSTRUCTIONS BEFORE USING THIS TOOL!

- Dress properly. Do not wear loose clothing or jewelry as they can be caught in moving parts. Protective, electrically non-conductive clothes and non-skid footwear are recommended when working. Wear restrictive hair covering to contain long hair
- Use eye and ear protection. Always wear ANSI approved impact safety goggles.
- Stay alert. Watch what you are doing, use common sense. Do not operate any tool when you are tired.
- Guard against electrical shock. Prevent body contact with grounded surface such as pipes, radiators, ranges and refrigerator enclosure.
- Do not operate tool if under the influence of alcohol or drugs. Read warning labels on prescriptions to determine if your judgement or reflexes will be impaired. If there is any doubt, do not operate the tool.

### PREPARE WORK AREA FOR JOB

- Keep work area clean. Cluttered areas invite injuries.
- Observe work area conditions. Do not use machines or power tools in damp or wet locations. Do not expose to rain.
- Keep work areas well lighted. Do not use electrically powered tools in the presence of flammable gases or liquids.
- Keep children away. Children must never be allowed in the work area. Do not let them handle machines, tools or extension cords.
- Use proper size and type extension cord.
- If an extension cord is required, it must be of proper size and type to supply the correct current to the tool without heating up. Otherwise, the extension cord could melt and catch fire, or cause electrical damage to the tool. If you are using the tool outdoors, use an extension cord rated for outdoor use (signified by "WA" on the jacket).

**SAFETY RULES CONTINUED**

**TOOL SHOULD BE MAINTAINED**

- Store idle equipment. When not in use, tools must be stored in a dry location to inhibit rust. Always lock up tools and keep out of reach of children.
- Maintain tools with care. Keep tools sharp and clean for better and safer performance. Follow instructions for lubricating and changing accessories. Inspect tool cords periodically and if damaged, have them repaired by an authorized technician. The handles must be kept clean, dry and free from oil and grease at all times.
- Disconnect power. Unplug too when not in use.
- Replacement parts and accessories. When servicing, use only identical replacement parts. Use of any other parts will void the warranty. Only use accessories intended for use with this tool. Approved accessories are available from your local retailer.
- Maintenance. For your safety, service and maintenance should be performed by a qualified technician.

**KNOW HOW TO USE TOOL**

- Do not force tool. It will do the job better and more safely at the rate for which it was intended. Do not use inappropriate attachments in an attempt to exceed the tool capacity.
- Use the right tool for the job. Do not attempt to force a small tool or attachment to do the work of a large industrial tool. There are certain applications for which this tool was designed. Do not modify this tool and do not use this tool for a purpose for which it was not intended.
- Do not overreach. Keep proper footing and balance at all times. Do not reach over or across machines while in operation.
- Remove adjusting keys and wrenches. Check that keys and adjusting wrenches are removed from the tool or machine work surface before plugging it in.
- Avoid unintentional starting. Be sure the switch is in the OFF position when not in use and before plugging in.
- Check for damaged parts. Before using any tool, any part that appears damaged should be carefully checked to determine that it will operate properly and perform its intended function. Check for alignment and binding of moving parts; any broken parts or mounting pieces should be properly repaired or replaced by a qualified technician. Do not use the tool if any switch does not turn ON and OFF properly.

**WARNING:** The warnings, cautions and instructions discussed in this instruction manual cannot cover all possible conditions and situations that may occur. It must be understood by the operator that common sense and caution are factors which cannot be built into this product, but must be supplied by the operator.

**SPECIFICATIONS\***

Chuck size .....	1/2"
Spindle taper .....	JT33
Spindle travel .....	2"
Spindle axis to column surface distance .....	4"
Spindle to base surface distance .....	11 1/2"
Spindle to table surface max distance .....	8 1/4"
Spindle speeds .....	5
Spindle RPM .....	750 – 3200

Table dimensions .....	6 1/2" x 6 1/2"
Table rotation around column .....	360°
Base size (L x W) .....	10 3/4" x 7"
Overall dimension (L x W x H) .....	17" x 8" x 23"
Net weight .....	35 lbs.
Motor .....	120V, 2.3 A, 300 W, 1/3 HP, 60 Hz
Motor RPM .....	1725
Column diameter .....	1-13/16" or 46mm

**\*NOTE:** Spindle measurements are from the bare spindle without the chuck.

**ASSEMBLY**

**TOOLS NEEDED FOR ENTIRE ASSEMBLY**

- Adjustable wrench
- Hammer with block of wood or rubber hammer
- Screwdriver

**BASE TO COLUMN**

1. Place the base on a stable surface (either on a sturdy table or the floor)
2. Set the column on the base, making sure to line up the three holes in both the base and column.
3. Insert a bolt, first with a lock washer then a flat washer, into each hole.
4. Tighten with a wrench.

**TABLE TO COLUMN**

1. Slide the table's sleeve onto the column and set at desired height.
2. Make sure to line up and center the table to the base, below.
3. Use the handle to tighten and lock in position.

**DRILL PRESS HEAD TO COLUMN**

1. Carefully place the head on the column, and ensure the head is seated properly on the column.
2. Align the drill spindle with the table and base.
3. Using the provided Allen wrenches, tighten the set screws on the side of the drill head, until the drill head can no longer swivel on the column.

**INSTALL THE DRILL CHUCK**

1. Using a clean cloth, inspect and clean the spindle and tapered hole of the chuck. Remove all grease, coatings and particles.
2. Ensure the chuck jaws are fully retracted.
3. Fit the chuck onto the spindle by placing a piece of wood under the chuck and tapping the wood with a hammer, or use a rubber hammer instead of the wood and normal hammer.

**WARNING:** Do not directly hit the chuck with a normal hammer.

**MOUNT THE DRILL PRESS**

If needed, the drill press can be mounted to a stand or work bench with heavy duty fasteners, using the slots on the base.

## INSTALLATION

**WARNING:** All electrical connections must be performed by a qualified electrician.

### POWER SOURCE

The motor is designed for operation on the voltage and frequency specified. Normal loads will be handled on voltages not more than 10% above or below the specified voltage.

Running the unit on voltages which are not within the range may cause overheating and motor burn-out. Heavy loads require that the voltage at motor terminals be no less than the voltage specified.

### GROUNDING INSTRUCTIONS

**WARNING:** Improper connection of equipment grounding conductor can result in the risk of electrical shock. Equipment should be grounded while use to protect operator from electrical shock. Check with qualified electrician if grounding instructions are not understood or if in doubt as to whether the tool is properly grounded.

### EXTENSION CORDS

- Your tool has a three-prong plug; therefore, you must use a three-prong extension cord. Only use rounded jacket extension cords listed by the UL.
- Improper use of extension cords may cause inefficient operation of your tool which can result in overheating. Be sure your extensions cord is rated to allow sufficient current flow to the motor. If you are using the tool outdoors, use an extension cord rated for outdoor use (signified by "WA" on the jacket).
- Avoid body contact with the grounded surfaces such as pipes radiators, ranges and refrigerators. There is an increased risk of electric shock if your body is grounded. If operating the power tool in damp locations is unavoidable, a Ground Fault Circuit Interrupter must be used to supply the power to your tool. Electrician's rubber gloves and footwear will further enhance your personal safety.
- Don't expose power tools to rain or wet conditions. Water entering a power tool will increase the risk of electric shock.
- Do not abuse the cord. Never use the cord to carry the tool or pull the plug from an outlet. Keep cord away from heat, oil, sharp edges or moving parts. Replace damaged cords immediately. Damaged cords increase risk of electric shock.
- The use of an extension cord will cause some drop in voltage and loss of power.
- Wires of the extension cord must be of sufficient size to carry the current and maintain adequate voltage.
- Use only 3-wire extension cords, having 3-prong grounding type plugs and 3-pole receptacles which accept the tool plug.
- If the extension cord is worn, cut or damaged in any way, replace it immediately.
- For wire size, lengths up to 25 ft. have an A.W.G. of 16. 25 ft. to 100 ft. have an A.W.G. of 14 NOTE: Using extension cords over 100 ft. are not recommended.

## OPERATION

### STARTING AND STOPPING THE DRILL

**WARNING:** Be sure drill bit is not in contact with workpiece when starting the motor. Start the motor and allow bit to come up to full speed before drilling.

- The ON/OFF switch is located on the front of the head casting.
- To turn drill ON, ensure the plastic key is inserted into the switch and flip the switch to the up position.
- To turn drill OFF, push the switch to the down position.

The drill can be locked from authorized use by locking the switch: To lock turn the switch to the OFF position, disconnect the drill from the power source, and remove the key from the switch.

**NOTE:** Should the key be removed from the switch at the ON position, the switch can be turned off but cannot be turned on again.

To replace key, slide key into the slot on switch until it snaps in.

### SPEED ADJUSTMENTS

**WARNING:** Ensure drill press is turned off and is disconnected from power source before adjusting speeds.



- To change the spindle speed, unlatch the plastic casing on the head, and loosen the bolts attaching the motor to the head, if needed.
- Push the motor towards the rest of the head, and use the locking knob on the same side as the drill quill handles, to lock the motor in position. This will loosen the belt and permit relocation to the desired pulley groove for desired spindle speed.
- After belt is repositioned, push motor back to original position and tighten the motor lock knob.
- Check belt for proper tension and make any final adjustments. A belt is properly tensioned when light pressure applied to mid-point of the belt produces about 1/2" deflection.

### TABLE ADJUSTMENTS

- To adjust the height, loosen the handle on the back of the sleeve, and slide along the column to desired height, and retighten the handle.
- To tilt the work table, loosen the table bolt/nut on the underside of the table and tilt to desired angle up to 45° and retighten.
- To obtain more distance between chuck and the table, the work table can be rotated to the back of the column using the steps from number 1 of this list. This permits drilling larger objects
- Clamp the table securely after all adjustments have been made.

**OPERATION (CONTINUED)**

**DEPTH STOP ADJUSTMENT**

To decrease the drilling depth, loosen the hex nuts on the opposite side of the head from the 3 quill feed handles. Using the depth measure, set the bottom of the hex nuts to the desired depth.

**MOUNT DRILL BIT**

**WARNING:** Ensure drill press is turned off and is disconnected from power source before mounting drill bit.

1. Place drill bit in jaws of chuck.
2. Using the chuck key, tighten using all 3 positions on chuck body and remove key.
3. Use only the self-ejecting chuck key provided with this drill press, or a duplicate. Use of any other key might allow start with the key still in the chuck. An airborne key could strike the operator and cause injury.



**MAINTENANCE**

**WARNING:** Turn switch off and remove power plug from wall outlet before maintaining or lubricating your drill press. Replace worn drive belt when needed.

**LUBRICATION**

The ball bearings are lubricated at the factory and need no further lubrication. Using 20 wt. non-detergent oil, periodically lubricate the splines (grooves) in the spindle and the rack (teeth on the quill) as follows:

1. Lower quill assembly all the way down.
2. Apply lubricant around the inside of the hole in the spindle pulley
3. Apply lubricant to rack (teeth) on quill, while fully extended.
4. Apply lubricant to rack and pinion gear on column and table assembly.
5. Frequently blow out any dust that may accumulate inside the motor. If the power cord is worn, cut, or damaged in any way, have it replaced immediately. For motor lubrication, follow instructions on motor plate.

**TROUBLESHOOTING**

<b>SYMPTOM</b>	<b>POSSIBLE CAUSE(S)</b>	<b>CORRECTIVE ACTION</b>
Noisy operation	<ol style="list-style-type: none"> <li>1. Incorrect belt tension</li> <li>2. Dry spindle</li> <li>3. Loose spindle</li> <li>4. Loose motor pulley</li> </ol>	<ol style="list-style-type: none"> <li>1. Adjust tension</li> <li>2. Lubricate spindle (see Maintenance)</li> <li>3. Tighten pulley nut</li> <li>4. Tighten set screw in pulley</li> </ol>
Bit burns or smokes	<ol style="list-style-type: none"> <li>1. Incorrect speed</li> <li>2. Chips not coming out of hole</li> <li>3. Dull bit</li> <li>4. Feeding too slow</li> <li>5. Bit not lubricated</li> <li>6. Bit running backwards</li> </ol>	<ol style="list-style-type: none"> <li>1. Change speed</li> <li>2. Retract bit frequently to clear chips</li> <li>3. Sharpen or replace bit</li> <li>4. Feed faster; enough to allow drill bit to cut</li> <li>5. Lubricate bit</li> <li>6. Check motor rotation to be sure it is clockwise facing shaft end</li> </ol>
Excessive drill run out or wobble	<ol style="list-style-type: none"> <li>1. Bent bit</li> <li>2. Bit not properly installed in chuck</li> <li>3. Chuck not installed properly</li> <li>4. Worn spindle bearings</li> </ol>	<ol style="list-style-type: none"> <li>1. Replace bit</li> <li>2. Install bit properly</li> <li>3. Install chuck properly</li> <li>4. Replace bearings</li> </ol>
Drill bit binds in work piece	<ol style="list-style-type: none"> <li>1. Workpiece pinching bit or excessive feed pressure</li> <li>2. Improper belt tension</li> <li>3. Workpiece not supported or clamped properly</li> </ol>	<ol style="list-style-type: none"> <li>1. Support or clamp work, decrease feed pressure</li> <li>2. Adjust belt tension</li> <li>3. Support or clamp workpiece securely</li> </ol>

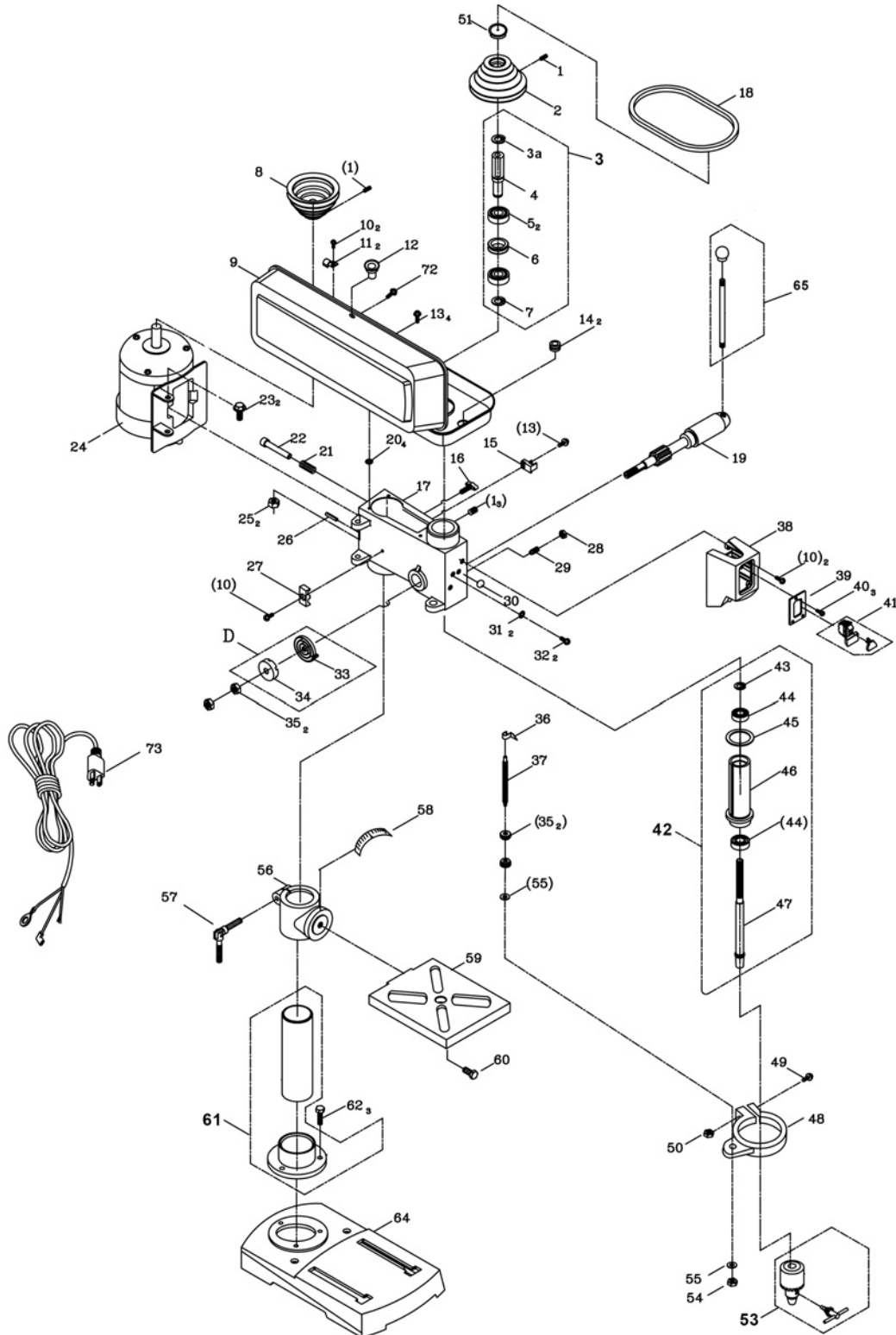

Replacement Parts Illustration for 8" Drill Press

## REPLACEMENT PARTS LIST FOR 8" DRILL PRESS

Ref. No.	Description	Part No.	Qty.	Ref. No.	Description	Part No.	Qty.
1	Hex screw 8 x 8mm	*	5	35	Hex nut 10mm	*	4
2	Spindle pulley	9639232.01	1	36	Pointer	9639250.01	1
3	Upper spindle assy. (3a thru 7)	9639233.01	1	37	Stop rod 10 x 1.5mm	9639249.01	1
4	Pulley Insert	NA	1	38	Switch box	9639238.01	1
5	Ball bearing 6203RZ	NA	2	39	Switch plate	9639239.01	1
6	Ring	NA	1	40	Philips screw ST4.2 x 10	*	3
7	Retaining ring	NA	1	41	Switch	9608066.01	1
8	Motor pulley	9639212.01	1	42	Lower spindle assembly (43 thru 47)	9639241.01	1
9	Pulley cover	9639220.01	1	43	Nut	NA	1
10	Philips screw 5 x 12mm	*	5	44	Ball Bearing 6201RZ	NA	2
11	Washer 5mm	*	2	45	Rubber washer	NA	1
12	Pulley cover knob	9639236.01	1	46	Quill	NA	1
13	Phillips screw 6 x 12mm	*	5	47	Spindle shaft	NA	1
14	Rubber bushing	*	2	48	Set ring	9639248.01	1
15	Key holder	9642740.01	1	49	Philips screw 5 x 20mm	*	1
16	Lock knob 8 x 16mm	9639210.01	1	50	Hex nut 5mm	*	1
17	Head	NA	1	51	Seal	9639229.01	1
18	V-Belt K690	9639213.01	1	53	Chuck & key	9639240.01	1
19	Pinion shaft	9639208.01	1	54	Hex nut 6mm	*	1
20	Flat washer M6	*	4	55	Flat washer 6mm	*	2
21	Compression spring	9639216.01	1	56	Table support	9639245.01	1
22	Motor stop	9639215.01	1	57	Lock handle	9639247.01	1
23	Hex screw 8 x 25mm	*	2	58	Scale	9639246.01	1
24	Motor	9639211.01	1	59	Table	9639244.01	1
25	Nut 8mm	*	2	60	Hex bolt 12 x 25mm	*	1
26	Spring pin 4 x 18mm	9639217.01	1	61	Column & collar assembly	9639206.01	1
27	Block	9639235.01	1	62	Hex bolt 8 x 25mm	*	3
28	Hex nut 8mm	*	1	64	Base	9639205.01	1
29	Quill screw 8 x 14mm	9639609.01	1	65	Feed handle assembly	9639207.01	3
30	Grounding label	NA	1	70	Capacitor 16 $\mu$ F 250V	9640914.01	1
31	Lock washer 5mm	*	2	73	Power cable	9639218.01	1
32	Philips screw 5 x 8mm	*	2	$\Delta$	Operating Manual & Parts List	9640915.02	1
34	Spring cap cover assembly	9639227.01	1				

( $\Delta$ ) Not shown.

(N/A) Not available as repair part.

(\*) Standard hardware item, available locally.

## PALMGREN WARRANTY

C.H. Hanson / Palmgren warrants their products to be free of defects in material or workmanship. This warranty does not cover defects due directly or indirectly to misuse, abuse, normal wear and tear, failure to properly maintain the product, heated, ground or otherwise altered, or used for a purpose other than that for which it was intended.

The warranty does not cover expendable and/or wear part (i.e. v-belts, screws, abrasives, jaws), damage to tools arising from alteration, abuse or use other than their intended purpose, packing and freight. The duration of this warranty is expressly limited to the terms noted below beginning from the date of delivery to the original user.

**The Palmgren branded items carry the following warranties on parts:**

**All vises, clamps, positioning tables, tombstones, jack screws and vise accessories - LIFETIME.**

**All bench grinders, drill presses, tapping machines, band saws, lathes, milling machines, arbor presses, abrasive finishing machines and work stands - 3 YEARS.**

The obligation of C.H. Hanson / Palmgren is limited solely to the repair or replacement, at our option, at its factory or authorized repair agent of any part that should prove inoperable. Purchaser must lubricate and maintain the product under normal operating conditions at all times. Prior to operation become familiar with product and the included materials, i.e. warnings, cautions and manuals.

**Failure to follow these instructions will void the warranty.**

This warranty is the purchaser's exclusive remedy against C.H. Hanson for any inoperable parts in its product. Under no circumstances is C.H. Hanson liable for any direct, indirect, incidental, special or consequential damages including loss of profits in any way related to the use or inability to use our products. This warranty gives you specific legal rights which may vary from state to state.

**PALMGREN®**

**Palmgren - a C.H. Hanson Company**  
**2000 N. Aurora Rd., Naperville, IL 60563 U.S.A.**  
**or call 1-800-827-3398**