

# PALMGREN®

## CROSS SLIDE MILLING TABLES

### DESCRIPTION

Palmgren Cross Slide Milling Tables (36103 & 37123) are made from FC25 fine grain cast iron. The tables feature both X and Y axis movement and graduated dials can be adjusted for easy "0" setting. The tops are precision-ground to a 0.001" total indicator

reading. The solid steel ball crank handle does not extend below the base. These precision built slide tables are essential for accurate boring, drilling, grinding and milling operations.

### DIMENSIONS

Refer to Figure 1.

Stock No.		36103	37123
Table Length	A	10"	12"
Table Width	B	6"	6"
Height	H	4 <sup>3</sup> / <sub>8</sub> "	4 <sup>7</sup> / <sub>16</sub> "
Base Width	D	6 <sup>11</sup> / <sub>32</sub> "	6 <sup>11</sup> / <sub>32</sub> "
Mounting Centers	E	5 <sup>3</sup> / <sub>8</sub> "	5 <sup>3</sup> / <sub>8</sub> "
Keyway Centers	F	2 <sup>1</sup> / <sub>2</sub> "	3"
Keyway Centers	G	3"	3"
Base Keyway	I	5 <sup>5</sup> / <sub>8</sub> "	5 <sup>5</sup> / <sub>8</sub> "
Table Keyway	J	7 <sup>7</sup> / <sub>16</sub> "	7 <sup>7</sup> / <sub>16</sub> "
Handle Length	K	3"	3"
Base Length	L	7 <sup>5</sup> / <sub>8</sub> "	7 <sup>5</sup> / <sub>8</sub> "
Mounting Centers	M	6 <sup>5</sup> / <sub>8</sub> "	6 <sup>5</sup> / <sub>8</sub> "
Table Center to End	N	7 <sup>3</sup> / <sub>4</sub> "	7 <sup>3</sup> / <sub>4</sub> "
Table Center to End	O	4"	4"
Table to End	C	3 <sup>1</sup> / <sub>4</sub> "	3 <sup>1</sup> / <sub>4</sub> "
Longitudinal Travel		6"	8"
Cross Travel		4"	4"
Dial Division		0.001"	0.001"
Cross Travel per Turn		0.100"	0.100"
Longitudinal Travel per Turn		0.100"	0.100"
Weight		38 lbs.	43 lbs.
Shipping Weight		40 lbs.	45 lbs.

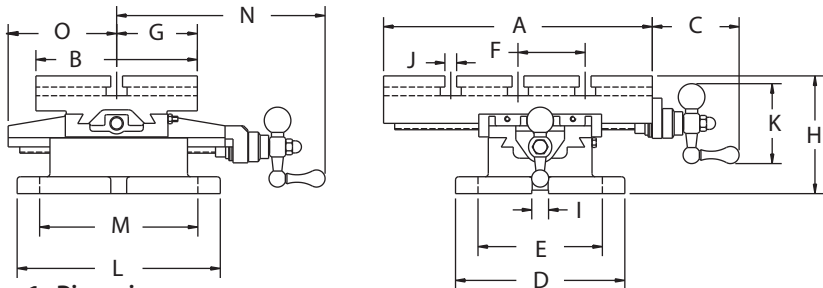

Figure 1 - Dimensions

## OPERATION AND MAINTENANCE

- Dovetail slides can be adjusted to move freely, or with minimum clearance as desired. Loosen the lock nuts (Ref. No. 17), and then adjust the gib screws (Ref. No. 16) until slide moves as desired. Tighten lock nuts to hold the setting.
- To lock the slide more securely during actual work, substitute a M5 slotted or socket head machine screw for the center gib screw. This can be tightened during work and loosened for moving the slide.
- The threaded steel collar (Ref. No. 11) on the acme threaded cross feed screws permit adjustment to minimize backlash.
- Depending on usage, the dovetails and leadscrews will require occasional lubrication. Lubricate the dovetail slides and leadscrews with non-detergent SAE30 oil.
- The graduated collars (Ref. No. 9) on the feed screws provide for reading at .001" increments. These collars can be set at 0° or any other convenient reading at start of work operation.
- Periodically wipe table with a rust-preventative oil.

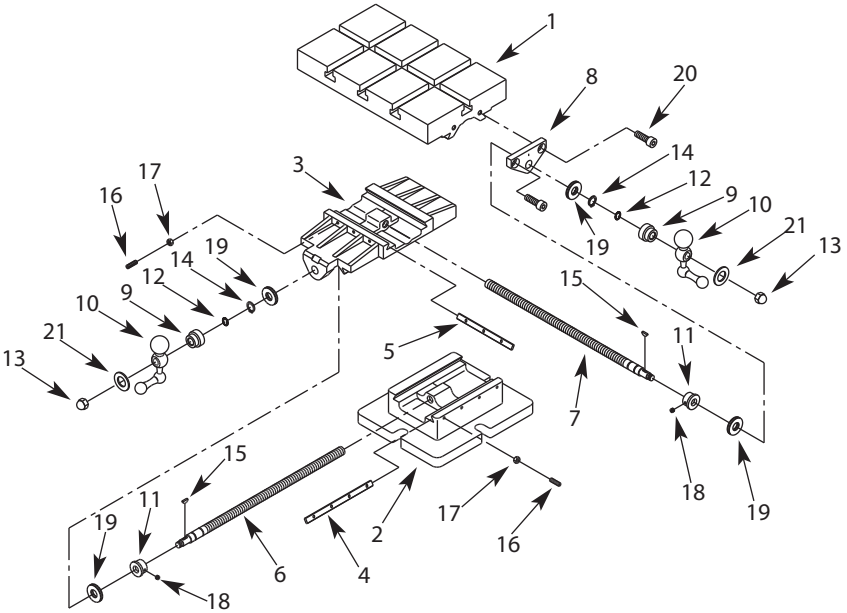

Figure 2 - Replacement Parts Illustration for Cross Slide Milling Table

**REPLACEMENT PARTS LIST FOR CROSS SLIDE MILLING TABLES**

Ref. No.	Description	Part Number for:		Qty.
		36103	37123	
1	Top	12923.00	12924.00	1
2	Base	12921.09	12921.09	1
3	Cross Slide	12922.09	12922.09	1
4	Gib Plate	12835.00	12835.00	1
5	Gib Plate	12834.00	12834.00	1
6	Feed Screw	12838.00	12838.00	1
7	Feed Screw	12929.00	12930.00	1
8	End Plate	12946.00	12946.00	1
9	Dial	12826.00	12826.00	2
10	Handle	12934.00	12934.00	2
11	Threaded Collar	12830.00	12830.00	2
12	O-Ring	12885.00	12885.00	2
13	8-1.25mm Acorn Nut	*	*	2
14	3AMI-12 Retaining Ring	12860.00	12860.00	2
15	2.5 x 10mm Woodruff Key	12879.00	12879.00	2
16	5-0.8 x 20mm Set Screw	*	*	7
17	5-0.8mm Hex Nut	*	*	7
18	5-0.8 x 5mm Set Screw	*	*	4
19	1226 Thrust Bearing Assembly	12864.10	12864.10	4
20	8-1.25 x 16mm Socket Head Bolt	*	*	2
21	Spacer	12859.00	12859.00	2

\* Standard hardware item available locally.

## WARRANTY

Palmgren warrants their products to be free of deficiency in material or workmanship. The duration of this warranty is expressly limited to one year parts and labor unless otherwise noted beginning from the date of delivery to the original user. The following Palmgren products carry the following warranties on parts with a 1 year warranty on labor:

- USA Machine vises – Lifetime
- Imported Machine vises – 2 years
- Bench vises – 2 years
- Positioning tables – 2 years
- Bench grinders & buffers – 3 years
- Tapping machines – 2 years
- Drilling machines – 2 years
- Finishing machines – 2 years
- Band saws – 2 years
- Work stands – 2 years

The obligation of Palmgren is limited solely to the repair or replacement, at our option, at its factory or authorized repair agent of any part that should prove deficient. The warranty does not cover expendable and/or wear parts (i.e. v-belts, coated abrasives), damage to tools arising from alteration, abuse or use other than their intended purpose, packing and freight. Purchaser must lubricate and maintain the product under normal operating conditions at all times. Proper use and care instructions are provided in the operator's manual. Failure to follow these instructions will void the warranty.

This warranty is the purchaser's exclusive remedy against Palmgren for any deficiency in its products. Under no circumstances is Palmgren liable for any direct, indirect, incidental, special or consequential damages including lost profits in any way related to the use or inability to use our products. This warranty gives you specific legal rights which may vary from state to state.

## SERVICE & REPAIR

1. If a Palmgren product requires a repair or warranty service **DO NOT** return the product to the place of purchase.
2. All warranty related work must be evaluated and approved by Palmgren.
3. Prior to returning any item the user must obtain factory approval and a valid RGA number.
4. For instructions and RGA number call toll free (800) 621-6145.