

PALMGREN®

HORIZONTAL/VERTICAL ROTARY TABLES

DESCRIPTION

Palmgren Horizontal/Vertical Rotary Tables (32806 & 34105) are equipped with keyways and bolt slots for both horizontal and vertical mounting. The table top and the vertical/horizontal base are ground for overall squareness. Rotary movement is calibrated in degrees around the full circumference of the top. Rotary feed dials are graduated in 3-minute increments. Tables can be locked against rotation. Handle clears machine table work surface. These rugged, precision-made tables are of industrial quality.

DIMENSIONS

Refer to Figure 1.

Stock No.		32806	34105
Base Width	A	9 ¹¹ / ₁₆ "	9 ¹¹ / ₁₆ "
Overall Width	B	11 ³ / ₈ "	12 ³ / ₈ "
Table Centerbore	C	1 ⁵ / ₈ " x ³ / ₄ " Deep	1 ⁵ / ₈ " x ³ / ₄ " Deep
Surface Width	D	8 ¹ / ₁₆ "	8 ¹ / ₁₆ "
Base Center to Slot	E	1 ³ / ₈ "	1 ³ / ₈ "
Table Diameter	F	8"	10"
Slot Length	G	1 ²¹ / ₃₂ "	1 ²¹ / ₃₂ "
Height	H	3 ¹⁵ / ₁₆ "	3 ⁷ / ₈ "
Base Keyway	I	⁵ / ₈ "	⁵ / ₈ "
Top Keyway	J	⁵ / ₈ "	⁵ / ₈ "
Handle Length	K	3"	3"
Base Length	L	12"	12"
Mounting Centers	M	10 ¹ / ₄ "	10 ¹ / ₄ "
Keyway to Bottom	N	1 ¹ / ₂ "	1 ¹ / ₂ "
Handle Center to Bottom	O	2 ¹ / ₈ "	2 ¹ / ₈ "
Table Center to Surface	P	6 ³ / ₁₆ "	6 ³ / ₁₆ "
Dial Division		3 Minutes	3 Minutes
Rotation per Turn		9°	9°
Gear Ratio		40:1	40:1
Weight		44 lbs.	50 lbs.
Shipping Weight		46 lbs.	52 lbs.

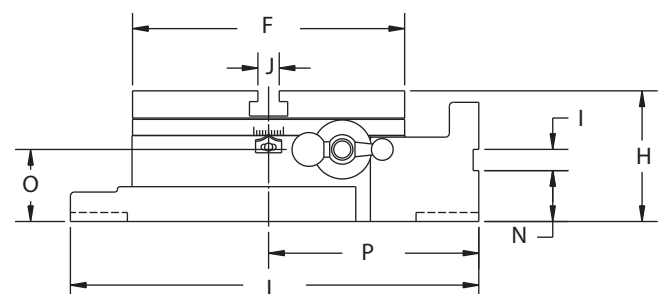
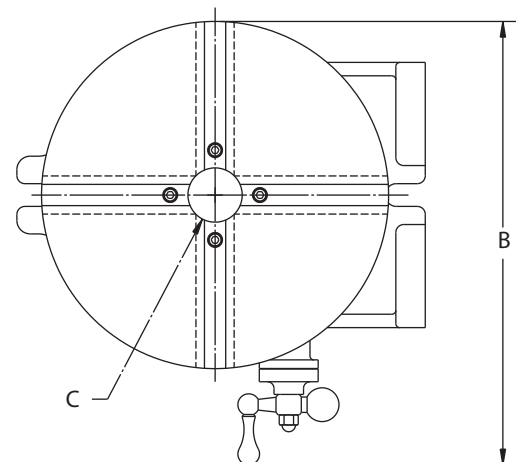
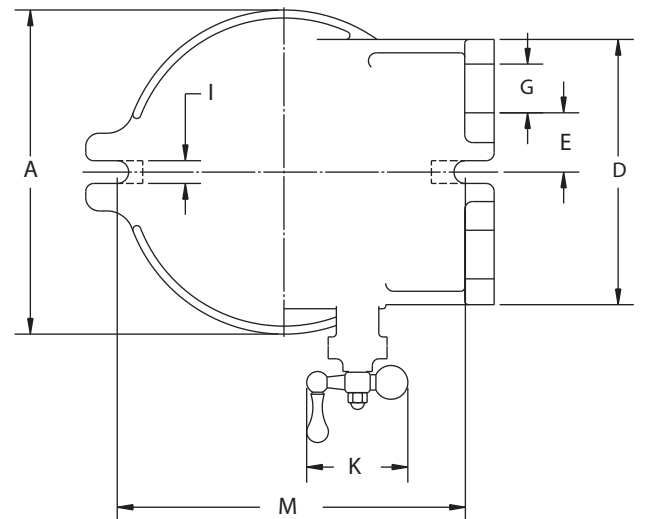

Figure 1 - Dimensions

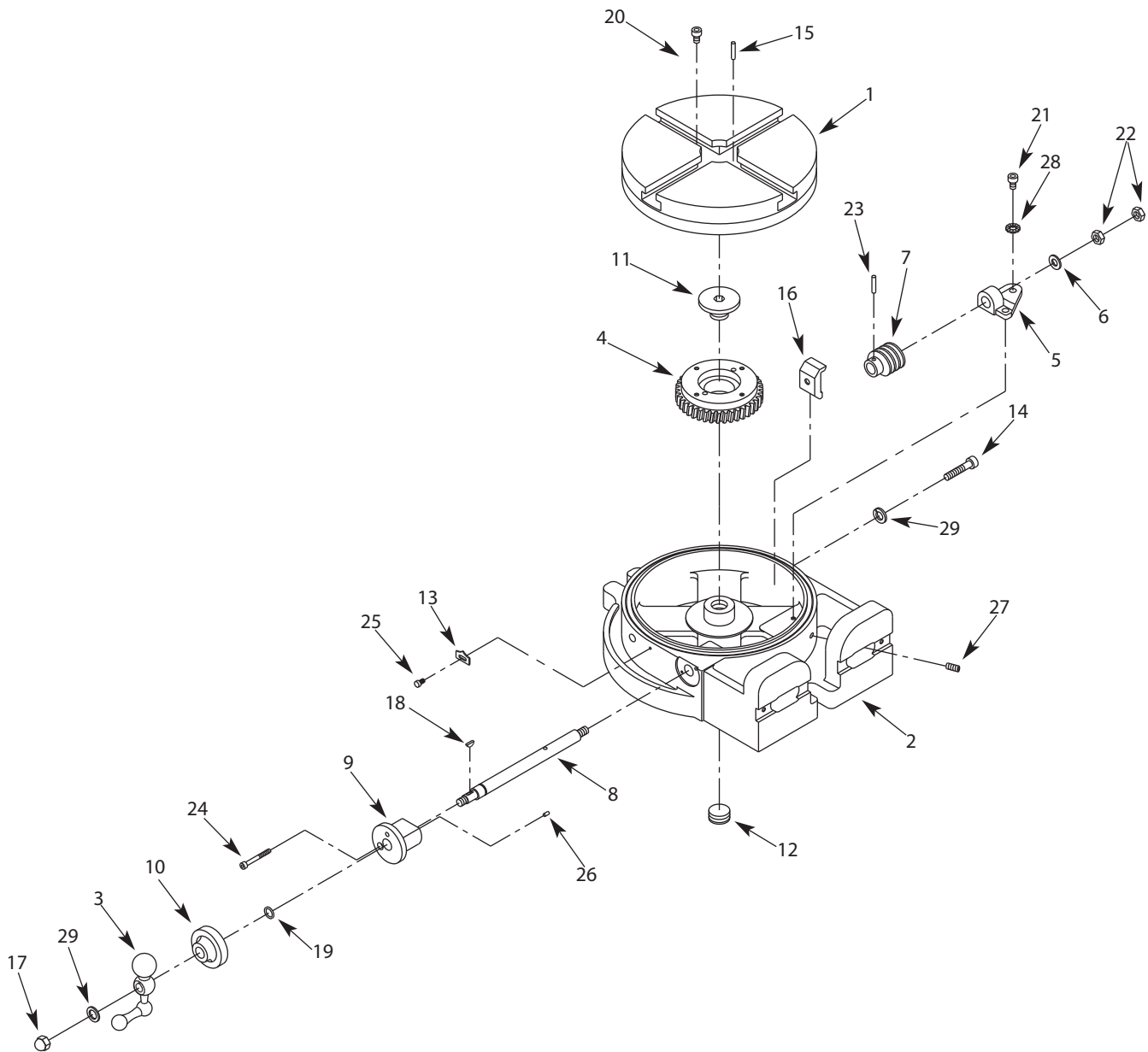

Figure 2 - Replacement Parts Illustration for Horizontal/Vertical Rotary Tables

REPLACEMENT PARTS LIST FOR HORIZONTAL/VERTICAL ROTARY TABLES

Ref. No.	Description	Part Number for:		Qty.
		32806	34105	
1	Top	12817.00	12810.00	1
2	Base	12818.09	12818.09	1
3	Handle	12934.00	12934.00	1
4	Worm Gear	12819.00	12819.00	1
5	Worm Shaft Bracket	12809.00	12809.00	1
6	Spacer	12848.00	12848.00	1
7	Worm	12824.00	12824.00	1
8	Worm Shaft	12821.00	12821.00	1
9	Collar	12861.00	12861.00	1
10	Dial	12828.00	12828.00	1
11	Retainer Screw	12832.00	12832.00	1
12	Set Screw	12880.00	12880.00	1
13	Pointer	12878.00	12886.00	1
14	8-1.25 x 35mm Socket Head Bolt	*	*	2
15	5 x 25mm Dowel Pin	12852.00	12852.00	2
16	Locking Clamp	12812.00	12812.00	2
17	8-1.25mm Acorn Nut	*	*	1
18	2.5 x 10mm Woodruff Key	12879.00	12879.00	1
19	O-Ring	12898.00	12898.00	1
20	6-1.0 x 20mm Socket Head Bolt	*	*	4
21	6-1.0 x 16mm Socket Head Bolt	*	*	2
22	8-1.25mm Hex Nut	*	*	2
23	4 x 20mm Dowel Pin	12863.00	12863.00	1
24	4-0.7 x 30mm Socket Head Bolt	*	*	1
25	4-0.7 x 10mm Pan Head Screw	*	*	1
26	3 x 6mm Dowel Pin	12867.00	12867.00	1
27	6-1.0 x 16mm Set Screw	*	*	1
28	6mm Serrated Washer	*	*	2
29	Spacer	12883.00	12883.00	3

* Standard hardware item available locally.

OPERATION AND MAINTENANCE

- Adjustment of the worm and gear requires removal of the top (Ref. No. 1). First loosen the two locking clamp screws (Ref. No. 14) located on the outside rim to disengage the internal locking clamps (Ref. No. 16). To remove the top, take out the four socket head cap screws (Ref. No. 20) near the center. The top will then lift off. Be sure to lift the top straight up because of the snug fit of the two dowel pins (Ref. No. 15). Make a mark so that the tabletop and dowels will be replaced in the same location as originally assembled.
- To adjust the worm and gear loosen the two screws (Ref. No. 21) holding the worm shaft bracket (Ref. No. 5) and make adjustment with the back-up adjusting screw (Ref. No. 27) in the rim of the top slide casting. Tighten the bracket hold-down screws after adjustment is made and replace the top.
- Depending on usage, the worm and gear will require occasional lubrication. The worm gear (Ref. No. 4) can be lubricated from the underside by turning the table on its side. We recommend No. 2 grease to lubricate the worm and worm gear.
- Indexing table tops are graduated the full 360 degrees, with the 0° marking to coincide with the axis of the T-Slots. The brass pointer (Ref. No. 13) has a slotted hole to provide for line up at start of work operation.
- The graduated dial collars (Ref. No. 10) on the index shaft are calibrated for direct reading at increments of 1/20 degrees (3 minutes).
- Periodically wipe table with a rust-preventative oil.

WARRANTY

Palmgren warrants their products to be free of deficiency in material or workmanship. The duration of this warranty is expressly limited to one year parts and labor unless otherwise noted beginning from the date of delivery to the original user. The following Palmgren products carry the following warranties on parts with a 1 year warranty on labor:

- USA Machine vises – Lifetime
- Imported Machine vises – 2 years
- Bench vises – 2 years
- Positioning tables – 2 years
- Bench grinders & buffers – 3 years
- Tapping machines – 2 years
- Drilling machines – 2 years
- Finishing machines – 2 years
- Band saws – 2 years
- Work stands – 2 years

The obligation of Palmgren is limited solely to the repair or replacement, at our option, at its factory or authorized repair agent of any part that should prove deficient. The warranty does not cover expendable and/or wear parts (i.e. v-belts, coated abrasives), damage to tools arising from alteration, abuse or use other than their intended purpose, packing and freight. Purchaser must lubricate and maintain the product under normal operating conditions at all times. Proper use and care instructions are provided in the operator's manual. Failure to follow these instructions will void the warranty.

This warranty is the purchaser's exclusive remedy against Palmgren for any deficiency in its products. Under no circumstances is Palmgren liable for any direct, indirect, incidental, special or consequential damages including lost profits in any way related to the use or inability to use our products. This warranty gives you specific legal rights which may vary from state to state.

SERVICE & REPAIR

1. If a Palmgren product requires a repair or warranty service **DO NOT** return the product to the place of purchase.
2. All warranty related work must be evaluated and approved by Palmgren.
3. Prior to returning any item the user must obtain factory approval and a valid RGA number.
4. For instructions and RGA number call toll free (800) 621-6145.