



# Cougartron Power 30 / Power 30x / ProPlus

## User Guide



**Original instructions**

**Read this guide before using the equipment**

**Retain this guide for future use**

Published on: 22 May 2024  
Document ID: WELC6012 - 1.0

### **Purpose of manual**

This manual enables safe and efficient use of Cougartron Power / ProPlus Series devices. This manual is part of the device and must be stored where it is always accessible to operating personnel.

The operating personnel must carefully read and understand this manual prior to beginning any work. The basic prerequisite for safe work is compliance with all safety instructions and operating instructions in this manual.

The local occupational safety regulations and general safety regulations for the area of application of the device also apply.

### **Copyright**

Copyright © 2024 Cougartron ApS. All Rights Reserved.

Contains information owned by Cougartron ApS. and/or its affiliates. Do not copy, store, transmit or disclose to any third party without prior written permission from Cougartron ApS.

Other product and company names may be trademarks or registered trademarks of other companies and are the property of their owners. They are used only for explanation, without intent to infringe.

### **Contact address**

Cougartron ApS.  
Brydehusvej 23  
2750 Ballerup, Denmark  
sales@cougartron.com  
+45 4346 2010

# Contents

<b>1 Safety information</b>	<b>5</b>
1.1 Safety notices	5
1.2 Intended use	6
1.3 Safety symbols	7
1.4 PPE requirements	7
1.5 Safe operating area	8
1.6 Residual risks	8
1.6.1 Electrical	9
1.6.2 Heat	9
1.6.3 Fire	9
1.6.4 Corrosive	10
1.6.5 Tripping	10
1.6.6 Heavy	10
1.7 Responsibility of the owner	11
1.7.1 Owner responsibilities	11
<b>2 Hardware description</b>	<b>13</b>
2.1 Overview	13
2.2 Main parts	14
2.3 Power switch	16
2.4 Dimensions	17
2.5 Device identification	18
2.6 Control panel	19
<b>3 Getting started</b>	<b>21</b>
3.1 Unpacking the device	21
3.2 Turning the device on	21
3.3 Shutting the device down	24
<b>4 Operations</b>	<b>25</b>
4.1 Overview of applications	25
4.2 Selecting the brush	26
4.3 Cleaning weld surfaces	26
4.3.1 Selecting the clean function	27
4.3.2 Cleaning the surface	27

4.4 Polishing surfaces .....	29
4.4.1 Selecting the polish function .....	30
4.4.2 Polishing the surface .....	30
4.5 Marking surfaces .....	31
4.5.1 Selecting the marking function .....	31
4.5.2 Marking and etching the surface .....	32
<b>5 Service and maintenance .....</b>	<b>35</b>
5.1 Cleaning the device .....	35
5.2 Inspecting the device .....	37
5.3 Replacing parts .....	37
5.3.1 Cougartron brushes .....	37
5.3.2 Cougartron twist shrouds .....	37
5.3.3 Cougartron fluids .....	38
5.4 Spare parts diagram - Power 30 and Power 30x .....	39
5.5 Spare parts diagram - ProPlus .....	40
5.6 Disposal .....	41
<b>6 Troubleshooting .....</b>	<b>43</b>
6.1 Error codes .....	44
<b>7 Specifications .....</b>	<b>47</b>
7.1 List of specifications .....	47
7.2 Spare parts and part numbers .....	48
7.2.1 Weld cleaning device accessories .....	48
7.2.2 Weld cleaning brush .....	48
7.2.3 Weld cleaning brush accessories .....	48
7.2.4 Weld cleaning fluids .....	49
7.2.5 Weld cleaning fluid accessories .....	49
7.2.6 Marking sets and accessories .....	50
7.2.7 Marking fluids .....	50
7.2.8 Marking stencils and printers .....	51
<b>Index .....</b>	<b>53</b>

# 1 Safety information

This section provides an overview of all safety aspects for the protection of people as well as safe and uninterrupted operation. Other task-related safety instructions are included in the specific sections.

## 1.1 Safety notices

The following safety notice formats are used in this manual. Safety notices are used at the start of sections or embedded in operating instructions.

Ensure you fully understand and comply with the notices in this manual.



### **DANGER**

#### **Risk of death!**

Indicates a hazardous situation which, if not avoided, will almost certainly result in death or serious injury.



### **Caution**

#### **Risk of injury!**

Indicates a hazardous situation which, if not avoided, could result in minor or moderate injury.



### **WARNING**

#### **Risk of serious injury or death!**

Indicates a hazardous situation which, if not avoided, could result in death or serious injury.



Additional information relating to the current section.



### **Notice**

Indicates an important situation which, if not avoided, may seriously impair operations.

## 1.2 Intended use

Cougartron Power / ProPlus Series devices are electrochemical weld cleaning devices for stainless steel and aluminium welds and surfaces.

The device is used to remove rust, oxidation, and other forms of contamination across a range of weld types and metal thicknesses.



### WARNING

#### Danger due to misuse!







Misuse of the device can result in hazardous situations.

- The device is not designed for use on power generators or step down transformers.
- The weld cleaner must never be used on a workpiece whilst welding is being carried out on the same workpiece as this will damage the electronics in the weld cleaner.
- Only use the device in a well-ventilated space.
- Only operate the device if it is in an undamaged and orderly condition.
- Never deviate from the prescribed maintenance intervals.
- Only use parts that are specified in the technical data and approved for this device.
- Never modify the device without consulting with the manufacturer.
- Never allow untrained personnel to operate the device.
- Never operate the device in potentially explosive atmospheres
- The device is not to be used by persons (including children) with reduced physical, sensory or mental capabilities, or lack of experience and knowledge, unless they have been given supervision or instruction.
- Children being supervised not to play with the device.
- The instructions for devices incorporating a functional earth states that the device incorporates an earth connection for functional purposes only.

## 1.3 Safety symbols

To draw attention to special hazards, the following symbols are used in this manual.



**Table 1 - Safety symbols**

Symbol	Meaning
	Electrical hazards and electrical shock hazards
	General warning
	Heavy objects or equipment
	Fire hazard
	Corrosive substance
	Trip hazard
	Hot surface

## 1.4 PPE requirements

Gloves and eye protection must also be worn during installation and usage of the device.

**Table 2 - PPE requirements**

Symbol	Meaning
	The device uses mild acids
	Gloves must be worn to avoid prolonged skin contact with any of the fluids
	Goggles must be worn to prevent fluid splashing in the eyes

---

Symbol	Meaning
	Air extraction must always be used when working with the device

---

## 1.5 Safe operating area

A safe operating area around the device and work area should be maintained at all times. Non-operators and other persons should not approach the device or work area.

If you need to approach the device or work area, you must obtain permission from the operator to say that it is safe to do so.

Cougartron recommends a safe area of at least 2 m (6'6") from the operator while they are working.

You should also be aware of the main device location if it is located beyond this distance.

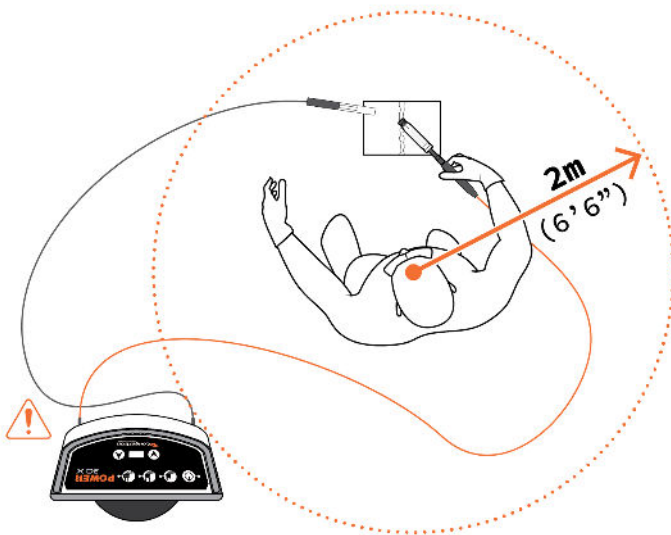

Figure 1 - Safe operating area

---

## 1.6 Residual risks

The device incorporates the latest technology and complies with current safety requirements. Nevertheless, there are some residual risks that require your attention. The following section lists the residual risks and the measures that result from them.



### 1.6.1 Electrical

**WARNING****Danger of death due to electrical current!**

There is an imminent risk of death by electrocution in the event of contact with live parts. Damage to the cable insulation or individual components can pose a lethal hazard.

- Only qualified electricians are authorized to work on the device.
- In case of damage to the cable insulation, immediately cut the power supply and initiate repairs or replacement.
- Keep moisture away from live components as it can result in a short circuit.

### 1.6.2 Heat

**WARNING****Risk of hot surfaces!**

The metal around the weld and the brushes can get hot during the cleaning process.

During use, the brush becomes extremely hot; +200°C (392°F).

- When operating the device, do not touch the brush.
- Do not place the brush near any flammable material.

### 1.6.3 Fire

**WARNING****Risk of fire or flammable materials!**

- Hydrogen gas (an invisible but explosive gas) might be generated while operating the device. Always use the device in a well-ventilated area with air extraction.
- Do not use the device near flammable substances or in areas where dense flammable gases, are likely to accumulate.
- The device produces an electric current that can generate small sparks between the brush and the work piece.

## 1.6.4 Corrosive



### WARNING

#### Risk of corrosive substances!

A mild acid is used as part of the device cleaning process.

- Wear appropriate protective clothing.
- Gloves must be used to avoid prolonged contact with any of the fluids.
- Goggles must be worn when operating the device.
- Any fluid spilled on the skin must be washed off immediately.
- A Material Safety Data Sheet (MSDS) is available for all fluids and should be read before use. Contact Cougartron for more details.

## 1.6.5 Tripping



### WARNING

#### Risk of injury from trips or falls!

There is a risk of tripping on the 4m earth or handle cables.

If the cables cross any access through a work area, then all necessary precautions must be followed to warn and notify other users in the area.

Ensure that cables are routed safely away from heat sources or other potential hazards.

Ensure the cables are not trapped or pinched during use.

## 1.6.6 Heavy



### WARNING

Care must be taken to use proper lifting techniques.

The Power 30/30x device weights 6.5 kg (14.3 lbs), and the ProPlus device weights 7.1 kg (15.7 lbs).

The device must be placed on a safe and stable area when being used.

Always use the machine handle to lift the device.

## 1.7 Responsibility of the owner

The owner is the person who operates the device for commercial or business purposes or allows a third party to use the device and bears legal responsibility for the product during operation for the protection of the user, personnel or third party. Note the device is not designed for use on power generators or step down transformers.

### 1.7.1 Owner responsibilities

The device is used for commercial purposes. The owner of the device is therefore subject to the legal responsibilities for occupational safety.

In addition to the safety instructions in this manual, the applicable safety regulations as well as occupational safety and environmental regulations must be implemented for the area of application of the device.

This applies to the following:

- The owner must be informed of the applicable occupational safety regulations and conduct a risk assessment to identify any additional risks that may arise due to the special working conditions at the device location.
- This information must be implemented in the form of operating instructions for the operation of the device.
- During the entire period of device use, the owner must ensure that the operating instructions created reflect the current state of policy and adjust them if necessary.
- The owner must clearly regulate and define the responsibilities for operation, troubleshooting, maintenance and cleaning.
- The owner must ensure that all persons who work with the device have read and understood this manual.
- The owner must also train and inform personnel of hazards at regular intervals.
- The owner must provide personnel with the required protective equipment and must ensure that personnel wear the required protective equipment.
- The owner must ensure adequate ventilation of the installation site around the device and work area.
- The owner is also responsible for ensuring that the device is always in good working order. The following therefore applies:
  - The owner must ensure that the maintenance intervals described in this manual are observed.
  - The owner must ensure that the required fire protection measures are always compliant and functional.

This page is intentionally left blank

## 2 Hardware description

To operate the Cougartron Power / ProPlus Series devices, you should be familiar with the descriptions of the device parts and systems.

### 2.1 Overview

The Cougartron Power 30, Power 30x, and ProPlus (device) are high-speed weld-cleaning systems designed for regular workshop usage and are very efficient in removing dis-coloration, heat tints, and oxides on metal surfaces after TIG welding.

The lightweight and portable device provides excellent results when cleaning, passivating and electropolishing. This is all done without any grinding, dust generation, or hazardous acids, such as pickling paste.

This manual covers the following variants of the device:

- Cougartron Power 30 WELC1055 (110-240 V ac 6.3Amps, 10.5-14 V ac/dc 30Amps, 50/60Hz)
- Cougartron Power 30x WELC1056 (110-240 V ac 6.3Amps, 10.5-14 V ac/dc 30Amps, 50/60Hz)
- Cougartron ProPlus WELC1016 (220-240 V ac 8Amps, 14 V ac/dc 50Amps, 50/60Hz)
- Cougartron ProPlus WELC1019 (110-130 V ac 10Amps, 14 V ac/dc 50Amps, 50/60Hz)

## 2.2 Main parts

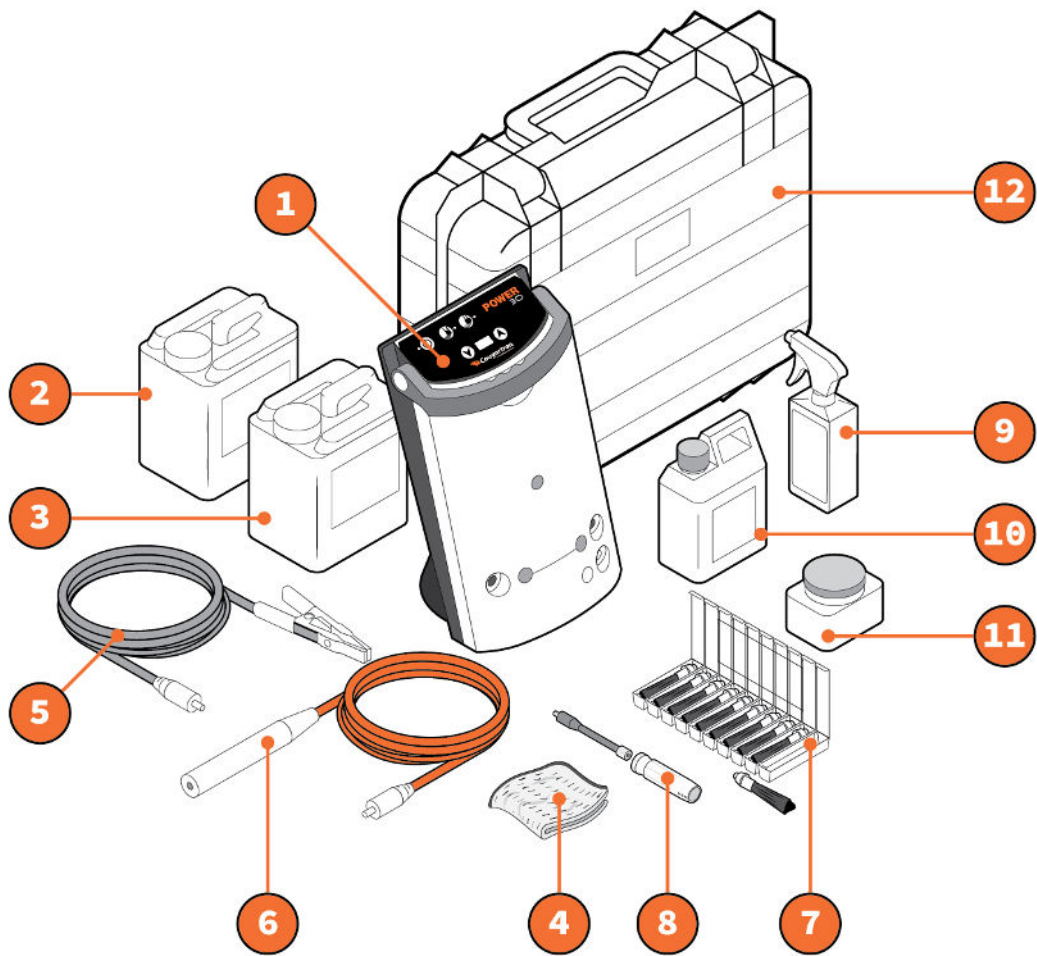

Figure 2 - Power30/30x main parts

**Table 3 - Power30/Power30x main parts**

Power 30/Power 30x			ProPlus	
Part number	Description	Part number	Description	
1	NA	Power 30 /Power 30x device	NA	PowerProPlus device
2	WELC3048	CGT-550 Weld Cleaning & Polishing Fluid - 5 L (1.3 Gal)	WELC3048	CGT-550 Weld Cleaning & Polishing Fluid - 5 L (1.3 Gal)
3	WELC3158	CGT-N5 HyPerformance Neutralising Fluid - 5 L (1.3 Gal)	WELC3158	CGT-N5 HyPerformance Neutralising Fluid - 5 L (1.3 Gal)
4	WELC2149	CGT Microfibre Cloth 40 cm x 40 cm (16" x 16")	WELC2149	CGT Microfibre Cloth 40 cm x 40 cm (16" x 16")
5	WELC2118	Cougartron lead with earth clamp 4 m(13ft), 50A (Xconnector)	WELC2118	Cougartron lead with earth clamp 4 m(13ft), 50A (Xconnector)
6	WELC2047	Cougartron lead with handle 4 m (13 ft), 50A (Xconnector)	WELC2047	Cougartron lead with handle 4 m (13 ft), 50A (Xconnector)
7	WELC3101	Cougartron Powerbrush (M6, 30 A)- 10 pack	WELC3146	Cougartron Superbrush (M6, 50 A)- 10 pack
8	WELC2226	Cougartron wand/twist shroud set (for 1x M6 brush)	WELC2226	Cougartron wand/twist shroud set (for 1x M6 brush)
9	WELC2201	Cougartron spray bottle with sprayer 0.5 L (1 pt) (empty)	WELC2201	Cougartron spray bottle with sprayer 0.5 L (1 pt) (empty)
10	WELC5014	1 L (2 pt) Jerry Can with screw cap	WELC5014	1 L (2 pt) Jerry Can with screw cap
11	WELC2005	Acid pot 500 ml (1 pt) with lid	WELC2005	Acid pot 500 ml (1 pt) with lid
12	WELC2064	Cougartron transport case - Large	WELC2064	Cougartron transport case - Large

## 2.3 Power switch

The Power switch is located on the rear of the main device.



### WARNING

#### Risk of serious injury or death!

Ensure the power switch is set to OFF before setting up the device and fitting the brush and handle.

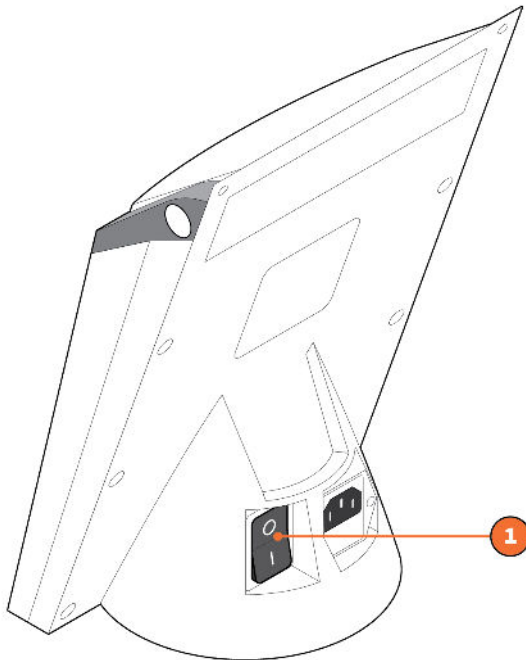

1 Power switch

Figure 3 - Location of the power switch



## 2.4 Dimensions



Cougartron Power / ProPlus Series devices		
1	Height	378 mm (3.1")
2	Width	220 mm (8.7")
3	Depth	170 mm (6.7")

Figure 4 - Main device dimensions

## 2.5 Device identification

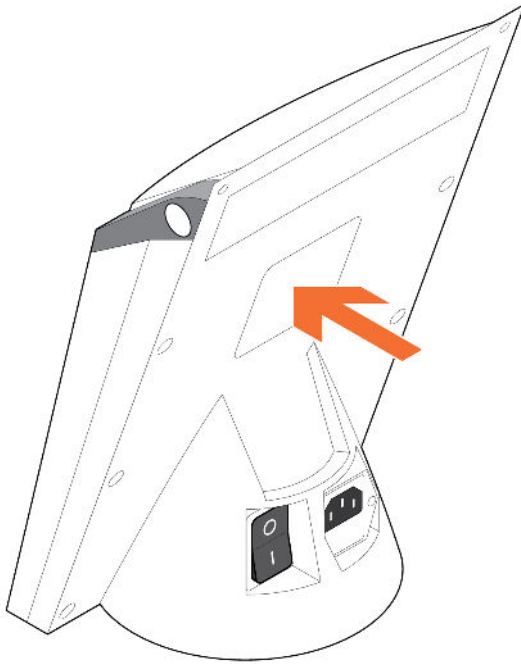

- 
- 1 Device identification label  
Location of device serial number
- 

Figure 5 - Location of the device identification label

---

## 2.6 Control panel

The control panel is located on the top of the device.

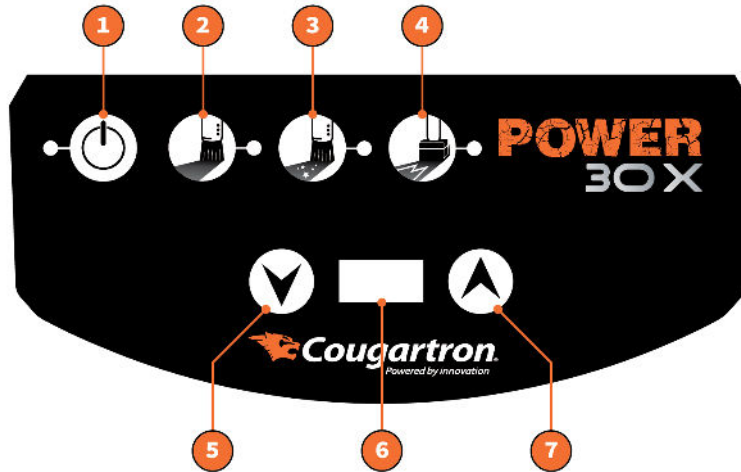









1 Standby		Used to power on and off the device. When the device is in standby there is no output to the work cables, but the device is turned on.
 <b>CAUTION:</b> The device should always be returned to standby when not in use to prevent accidental shorting of the work cables, and to prevent potential electrical shock.		
2 Clean function		Used to select the cleaning mode.
3 Polishing function		Used to select polishing and etching modes.
4 Marking function		Used to add a dark, oxidised mark or print on the work piece, with no change to the surface.
5 Down selection		Used to decrease the output amperage.
7 Up selection		Used to increase the output amperage.
6 OLED display		Used to display selected options and configure settings, for example power and amp settings.

Figure 6 - Control panel and buttons

This page is intentionally left blank

## 3 Getting started

This section describes the initial steps required to start using the device.

### 3.1 Unpacking the device

It is important to keep the following information in mind while unpacking the device:

1. Unpack the device.  
Dispose of the packaging correctly.
2. The following items are the minimum required to operate the device:
  - The device
  - A black cable with earth clamp
  - An orange cable with handle
  - Brush
  - Wand with twist shroud
  - Cleaning fluid
  - Neutralising fluid

### 3.2 Turning the device on

1. Inspect the device for damage before installing or operating it.  
If the device is damaged, do not use it. Contact your local Cougartron supplier to have the device inspected and repaired.
2. Use only single-phase AC power at 110 V/240 V.  
Do not use the device with any other voltage.  
▶ *For more information, see "Specifications" on page 47*
3. Ensure that the device is located where it cannot easily fall and cause injury.
4. Ensure the following:
  - The device is placed on an even and stable surface.
  - The surface is clean and dry.
  - The cables do not cause a trip hazard.

- The Power switch is in the OFF position.

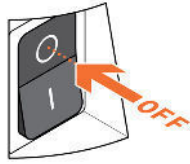

Figure 7 - Power switch in the off position

5. Attach the orange handle cable to the right-hand socket.
6. Screw the wand into the work handle of the orange handle cable until it is in the correct position.
7. Screw the brush into the wand until they are in the correct position. Ensure they are fully tightened.

To assist with removal of the brush after you have completed your work, Cougartron recommends applying a small amount of copper paste to the brush threads.

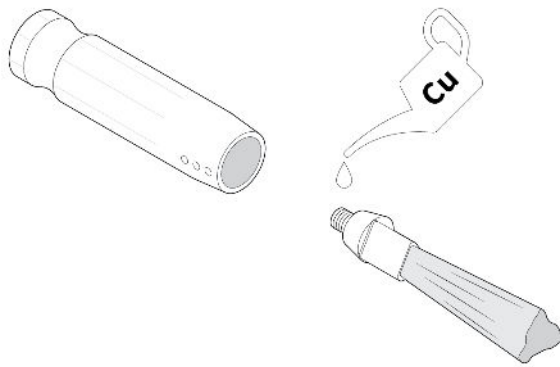

Figure 8 - Apply copper paste to the brush threads before assembly

8. Place the twist shroud over the brush and twist the twist shroud into the wand until it is in the correct position, leaving 5-10 mm of brush exposed at the end.

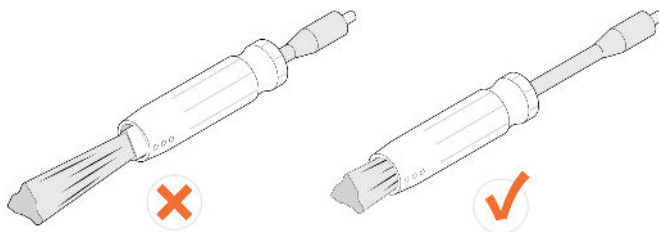

Figure 9 - Twist shroud fitted to the brush

9. Attach the black earth cable to the left-hand socket.
10. Connect the power cord to the power outlet.

**Caution****Risk of injury!**

Ensure that your device type matches your power outlet.

Mismatched power types can damage the device, work piece, and potentially harm the operator

Damage caused by connecting to an incorrect power outlet could void your warranty.

► For more information, see "Specifications" on page 47

11. Attach the earth clamp of the black earth cable to the work piece.



Figure 10 - Earth clamp attached to work piece

12. Turn the power switch to the ON position.

The device starts in five seconds. After the device is ready for use, it displays **Standby** on the OLED display.

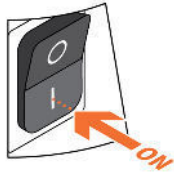

Figure 11 - Power switch in the ON position

---

13. Select the correct operating function by pushing the clean button or polish button.
  - ▶ For more information, see "Cleaning weld surfaces" on page 26

### 3.3 Shutting the device down

1. Turn the power switch to the OFF position.  
The OLED display turns off.

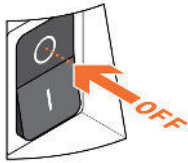

Figure 12 - Power switch in the OFF position

---

2. Disconnect the power cord from the power outlet.
3. Remove the earth clamp of the black earth cable from the work piece.
4. Disconnect the black earth cable from the left-hand socket.
5. Remove the twist shroud from over the brush and twist the twist shroud away from the wand.
6. Unscrew the brush from the wand.
7. Unscrew the wand from the work handle of the orange handle cable.
8. Disconnect the orange handle cable from the right-hand socket.
9. Rinse the thread on the brush and wand with water.
  - ▶ For more information, see "Cleaning the device" on page 35



## 4 Operations

This section describes common tasks required for the operation of the device.

### 4.1 Overview of applications

The device has different modes that the user can select for different tasks. The following tables provide some guidelines on what device configuration should be used with which types of applications.

**Table 4 - Power 30/ 30x modes**

Mode	Power	Current	Application
Clean Mode 1	10.5 V AC	5-30 A in 5 amp increments	Cleaning. 0-1.5 mm (1/16") thickness. Any weld type
Clean Mode 2	14 V AC	5-30 A in 5 amp increments	Cleaning. 1-3 mm (1/8") thickness. All TIG welds.
Mark Mode	10.5 V AC	2-10 A in 2 amp increments	Marking. Any thickness.
Polish Mode 1	10.5 V DC	5-30 A in 5 amp increments	Polishing. 0-3 mm(1/8") thickness.

**Table 5 - ProPlus modes**

Mode	Power	Current	Application
Clean Mode 1	10.5 V AC	5-50 A in 5 amp increments	Cleaning. 1-3 mm(1/8") thickness. Any weld type.
Clean Mode 2	14 V AC	5-50 A in 5 amp increments	Cleaning. 1-6 mm (1/4") thickness. All TIG welds and good MIG welds.
Mark Mode	10.5 V AC	2-10 A in 2 amp increments	Marking. Any thickness.
Polish Mode 1	10.5 V DC	20-200 A in 20 amp increments	Polishing. 0-6 mm(1/4") thickness.

## 4.2 Selecting the brush

The device can be used for effective cleaning of different sizes and shapes of work piece.

**Table 6 - Selecting the brush**

Device model	Part Number	Brush	Current
Power 30	WELC3101	Powerbrush 10 pack	30 A
Power 30x	WELC3101	Powerbrush 10 pack	30 A
ProPlus	WELC3146	Superbrush 10 pack	50 A

► For more information, see "Weld cleaning brush" on page 48

## 4.3 Cleaning weld surfaces

The clean and mark function uses AC current.

Use the clean function for the following tasks:

- Remove oxides
- Remove rust
- Remove discolouration after welding
- Re-passivate the Heat Affected Zone (HAZ) after welding

Use the mark function for the following task:

- Black mark stainless steel

**Table 7 - Clean function modes: Power 30/30x**





Mode	Power	Current
Clean Mode 1	10.5 V AC	5 A - 30 A
Clean Mode 2	14 V AC	5 A - 30 A
Mark Mode	10.5 V AC	2 A - 10 A

**Table 8 - Clean function modes: ProPlus**

Mode	Power	Current
Clean Mode 1	10.5 V AC	5 A - 50 A
Clean Mode 2	14 V AC	5 A - 50 A
Mark Mode	10.5 V AC	2 A - 10 A

### 4.3.1 Selecting the clean function

To select the clean function:

1. Press the clean button  on the control panel.  
The OLED display shows that the device is in clean function, 14 V.
2. Press the clean button  again to set the device to 10.5 V.  
The OLED display shows which mode the device is currently in.
3. Press the up-selection button  or down-selection button  on the control panel to adjust the current output limit.  
The OLED display shows the selected current limit.
4. When not using the device for a short period, press the standby button  to set the device to standby mode.

### 4.3.2 Cleaning the surface



#### Notice

If the whole surface of the brush is not in contact with the surface of the work piece, reduce the current.

If you notice a burning brush, black marks on the surface of the work piece, or excessive smoke, reduce the current and dip the brush in the fluid more regularly.



#### Caution

##### Risk of injury!

Avoid direct contact with all fluids used with the device. If fluids are spilled on the skin or face, wash them off with water immediately.

► For more information, see "PPE requirements" on page 7

1. Pour a small quantity of the cleaning and polishing fluid into a shallow container.  
Place the container close to the work piece while using the clean function. Only use recommended fluids.  
► For more information, see "Weld cleaning fluids" on page 49
2. Dip the brush into the cleaning fluid momentarily, until the brush is wet.

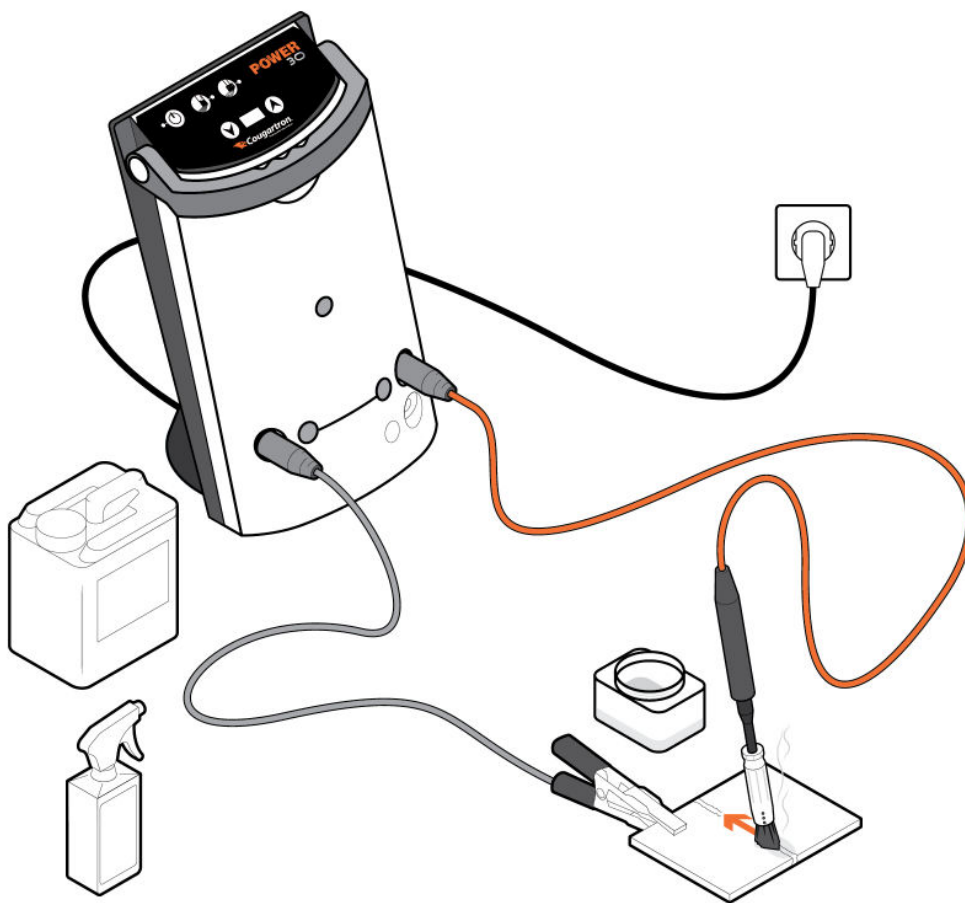

Figure 13 - Device set up for cleaning

3. Apply the wetted brush to the weld area to be cleaned and proceed in a circular motion along the weld seam. Do not use excessive pressure. For the best results use light strokes.
  - Ensure that the brush and work piece stay wet with the cleaning fluid during operation.
  - Apply the fluid only for as long as necessary to remove discolouration. Prolonged localised application can cause the work piece to overheat and damage the material.
  - Light sparking may occur where the brush comes in contact with the work piece, particularly on higher power settings. This is normal. Too much sparking for a long time in one area may cause pitting or corrosion.



**Caution**

**Risk of injury!**

Do not touch the brush as it might be very hot.

4. When the surface has the desired finish, press the standby button to put the device in standby mode.
5. Place the brush on a clean, non-conductive and non-flammable surface.
6. After use, and when the brush is cool, fully wash the brush with clean water to remove all traces of the cleaning and polishing fluid.
7. When done, turn the power switch to the OFF position.

## 4.4 Polishing surfaces

The polish function uses DC current.

Use the polish function for the following tasks:





- Electropolish stainless steel
- White etch on stainless steel

**Table 9 - Power and current requirements for each polish mode**

Device	Mode	Power	Current
Power 30/30x	Polish	10.5 V DC	5 A - 30 A
ProPlus	Polish	10.5 V DC	5 A - 50 A

### 4.4.1 Selecting the polish function

To select the polish function, follow these steps:

1. Press the polish button  on the control panel.  
The OLED display shows that the device is in polish function.
2. Press the up-selection button  or down-selection button  on the control panel to adjust the current output limit.  
The OLED display shows the selected current.
3. When not using the device for a short period, press the standby button  to set the device to standby mode.

### 4.4.2 Polishing the surface



#### Caution

#### Risk of injury!

Avoid direct contact with all fluids used with the device. If fluids are spilled on the skin, wash them off with water immediately.

► For more information, see "PPE requirements" on page 7

1. Pour a small quantity of the cleaning and polishing fluid into a shallow container. Only use recommended fluids.  
► For more information, see "Weld cleaning fluids" on page 49
2. Place the container close to the work piece while using the polish function.
3. Press the standby button to set the device to operating mode.
4. Dip the brush into the cleaning and polishing fluid momentarily.
5. Apply the wetted brush to the weld area to be polished.
6. Ensure that the brush and work piece stay wet with the cleaning fluid during the operation, and keep the following points in mind:
  - Apply the fluid only for as long as necessary to remove discolouration. Prolonged application may affect surface quality.
  - Light sparking may occur where the brush comes in contact with the work piece, particularly on higher power settings. This is normal. However, too much sparking for a long time in one area may cause pitting or corrosion.

**Caution****Risk of injury!**

Do not touch the brush as it might be very hot.

7. When the surface has the desired finish, press the standby button to set the device to standby mode.
8. Place the brush on a clean and non-flammable surface.
9. After use and when the brush is cool, fully wash the brush with clean water to remove all traces of the cleaning and polishing fluid.
10. Turn the power switch to the OFF position.

## 4.5 Marking surfaces

**Notice**

For marking, you need a marking set.

► For more information, see "Marking sets and accessories" on page 50

The marking function uses AC current.

Use the marking function for the following task:





- Add a dark, oxidised mark or print on the work piece, with no change to the surface.

**Table 10 - Power and current requirements for marking modes**

Mode	Power	Current
Mark Mode	10.5 V AC	1 A - 10 A

### 4.5.1 Selecting the marking function

To select the marking function, follow these steps:

1. Press the marking button  on the control panel.  
The OLED display shows what function is selected.
2. Press the up-selection button  or down-selection button  on the control panel to adjust the current output limit.  
The OLED display shows the selected current.
3. When not using the device for a short period, press the standby button  to set the device to standby mode.

## 4.5.2 Marking and etching the surface



### Caution

#### Risk of injury!

Avoid direct contact with all fluids used with the device. If fluids are spilled on the skin, wash them off with water immediately.

► For more information, see "PPE requirements" on page 7



### Notice

For marking and etching with the device, you need a marking set.

► For more information, see "Marking sets and accessories" on page 50

1. Take a piece of marking white felt.
2. Assemble the marking head by folding the felt over the carbon block.  
Use the rubber ring to secure the felt.

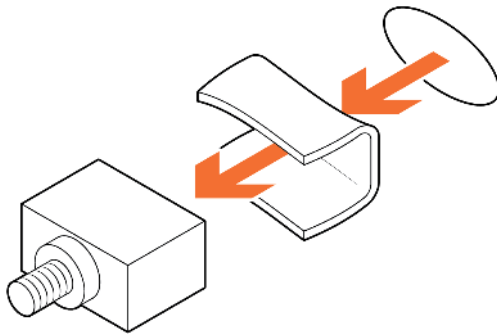

3. Unscrew the wand and weld cleaning brush from the handle and screw the marking head in.

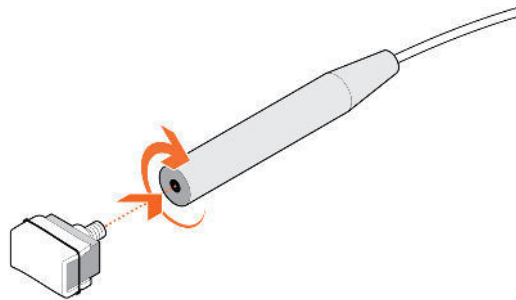

4. Place the marking stencil on the work piece.  
Use tape to secure the stencil.



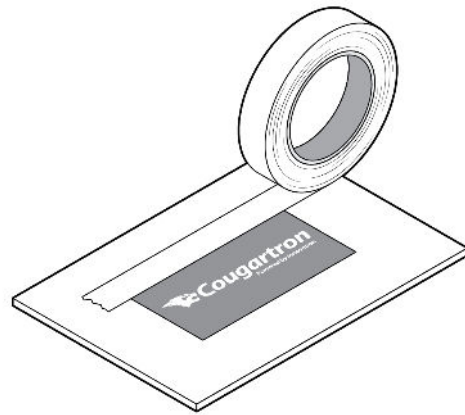

5. Apply the marking and etching fluid to the marking head.

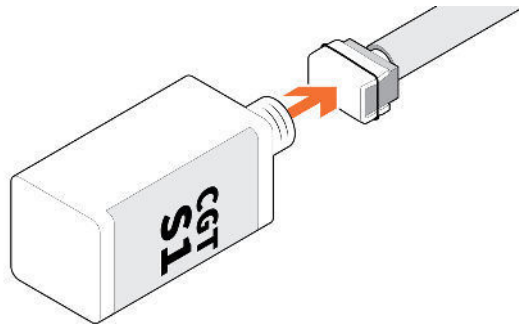

6. Drag the marking head slowly over the stencil.

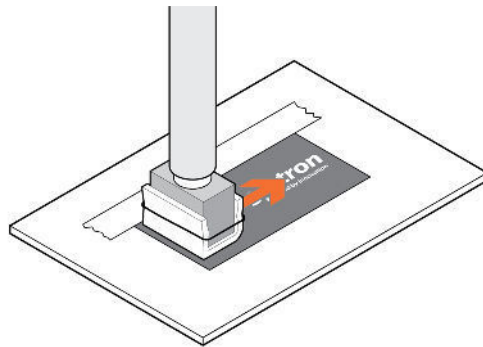

7. Remove the stencil.

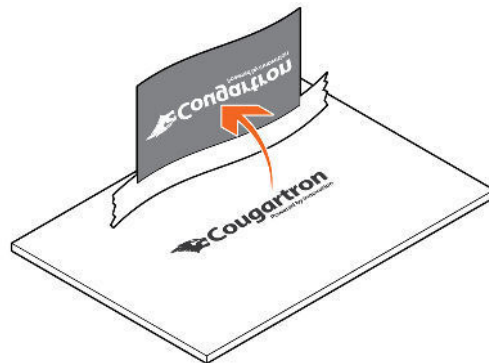

8. Apply a small amount of neutralizing fluid to the marked area of the work piece.

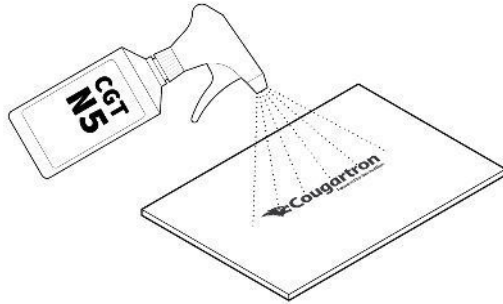

9. Wipe the marked area with a cloth.

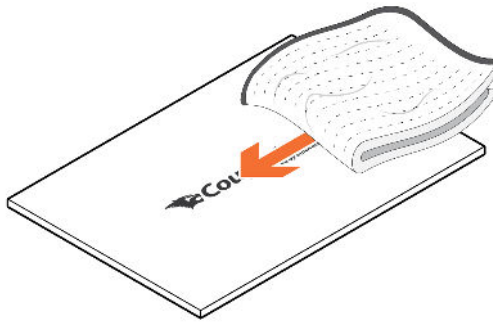

10. Press the standby button  to put the device in standby mode.
11. Place the marking head on a clean, non-conductive and non-flammable surface.
12. After usage and when the marking head is cool, fully wash the white felt with clean water to remove all traces of the etching fluid.
13. When done, turn the power switch to the OFF position.

## 5 Service and maintenance



### Caution

### Risk of injury!

The device must only be repaired by a qualified and trained person.

This section describes common tasks required for the service and maintenance of the device.

### 5.1 Cleaning the device

The following materials are required to clean the device:

- Clean water/running water installation
- Copper grease
- Small wire brush

Follow these steps to clean the device and ensure optimised functionality:

1. Ensure that the power switch is turned to the OFF position.  
The OLED display on the control panel turns off.
2. Ensure the brush has cooled down and is not hot.
3. Remove the wand from the work handle.
4. Remove the twist shroud from the wand.
5. Remove the brush from the wand.
6. Rinse the brush, twist shroud, and wand with clean water to remove solution.

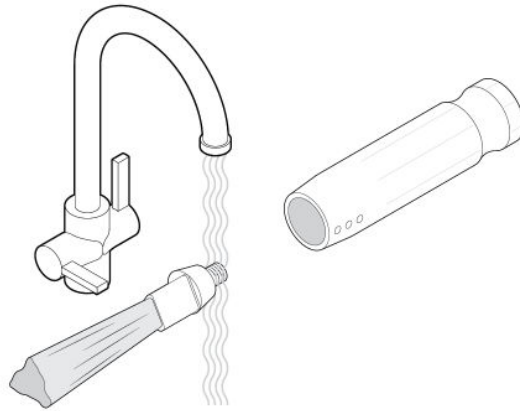

Figure 14 - Rinsing the brush

7. Flush the earth clamp on the black earth cable with clean water to remove the solution and prevent corrosion.
8. A small wire brush may be used on the threaded connections to remove any residue or dried acid.
9. When all parts are dry, apply a small amount of copper paste to the threads of the brush.  
This keeps the acidic solution out of the joints.
10. Use a dry cloth or paper towel to wipe fluid splashes off the device.
11. Assemble all parts.
  - *For more information, see "Unpacking the device" on page 21*

## 5.2 Inspecting the device

**Table 11 - Inspecting the device**

Task	Action	Frequency
Check device case	Visual check of device case and body. Ensure there are no holes or cracks where fluids can enter and damage the electronics.	Monthly
Check cables	Visual check of power input cable and black and orange work cables. Ensure there is no damage to the insulating cable covering, especially at the ends of the cables. Ensure that the connections are clean and free of corrosion and arc damage.	Weekly
Check wand and shroud assembly	Ensure the black insulating material on the wand is not damaged. Ensure the shroud is not worn or melted.	Weekly

► For more information, see "Replacing parts" on page 37

## 5.3 Replacing parts

For optimal results, use only Cougartron brushes, shrouds and fluids.

Consumable supplies are available from authorised Cougartron distributors.

► For more information, see "Spare parts and part numbers" on page 48

### 5.3.1 Cougartron brushes

The brushes wear down with use and should be replaced when the bristles reach approximately 12 mm (1/2") in length.

► For more information, see "Weld cleaning brush" on page 48

### 5.3.2 Cougartron twist shrouds

The insulating twist shroud may become damaged, or heat affected. If this happens, replacement shrouds may be purchased.

► For more information, see "Weld cleaning brush accessories" on page 48

### 5.3.3 Cougartron fluids

A range of genuine Cougartron fluids is available. Please check with your local Cougartron distributor for details of fluids available in your region.

Types of fluids available:

- Weld cleaning fluids - used for cleaning and, optionally, polishing
- Neutralising fluids - used to ensure removal of all cleaning fluid residue
- Finishing fluid - used to provide a clean, mark-free finish
- Marking fluids - can be used with custom stencils to indelibly mark metals

► *For more information, see "Weld cleaning fluids" on page 49*

## 5.4 Spare parts diagram - Power 30 and Power 30x

The following diagram shows the individual parts of the device with their part number.

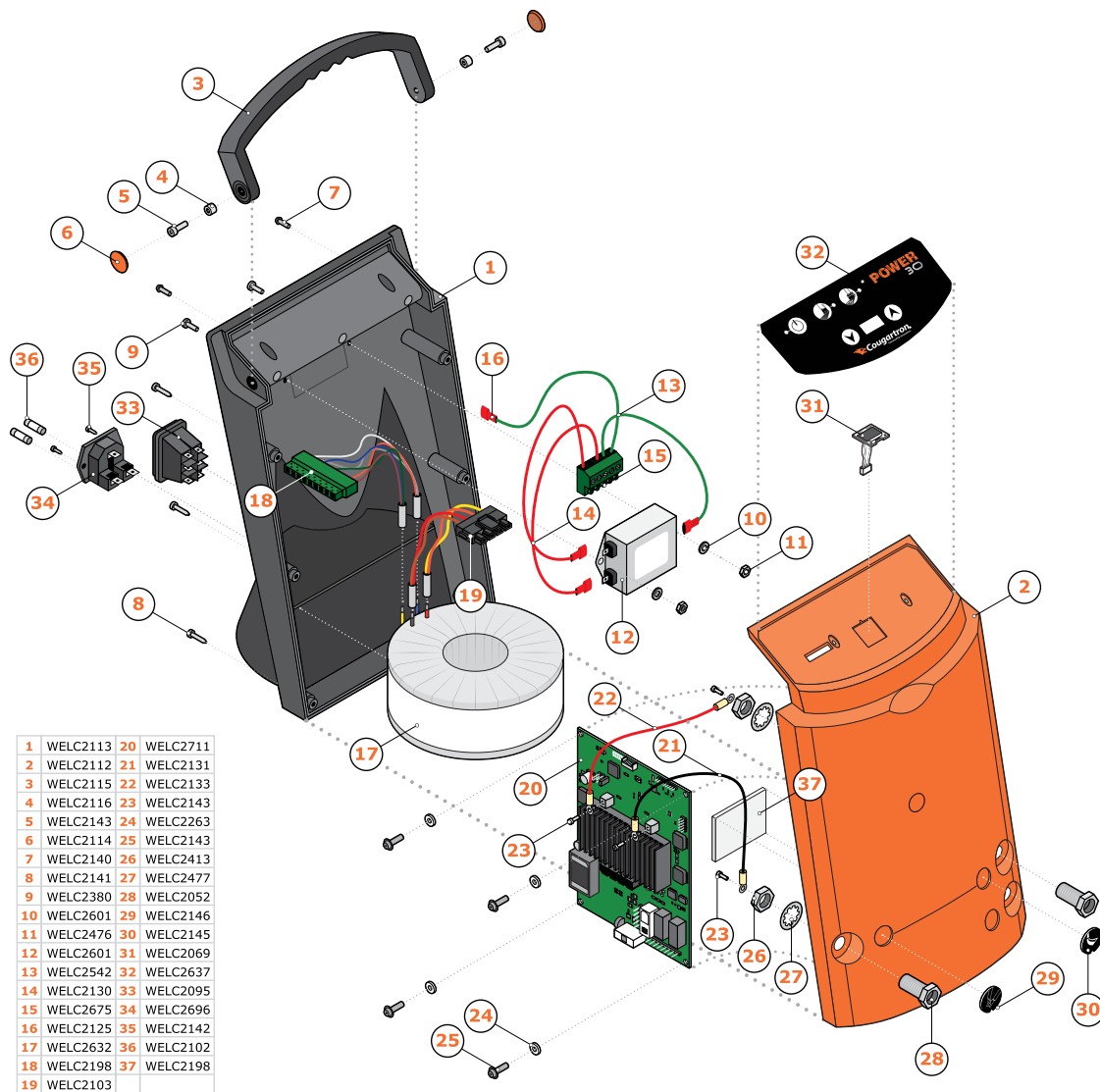

Figure 15 - Spare parts diagram - Power 30 and Power 30x

## 5.5 Spare parts diagram - ProPlus

The following diagram shows the individual parts of the device with their part number.

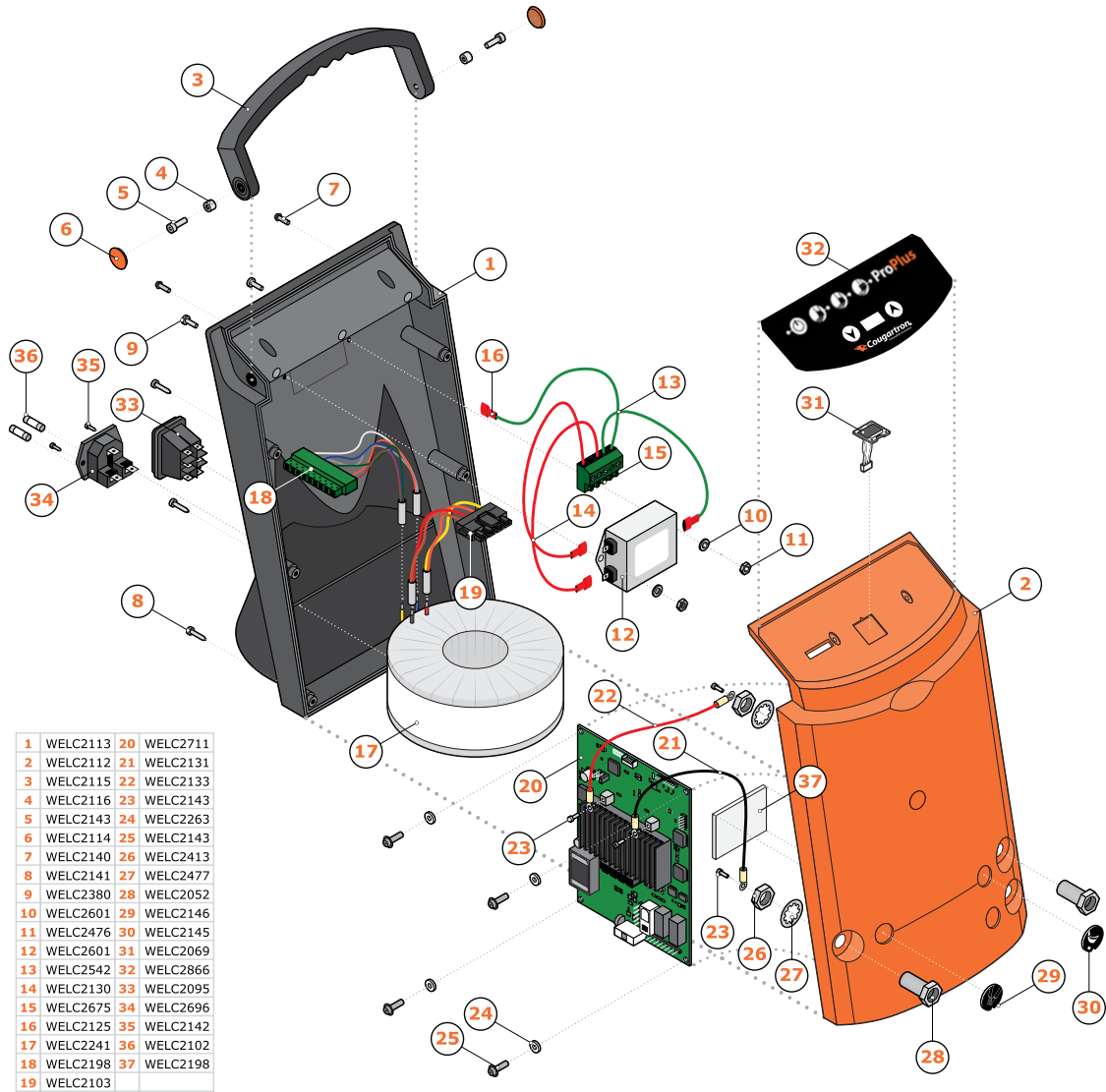

Figure 16 - Spare parts diagram - ProPlus



## 5.6 Disposal

The symbol on the device, the accessories, or packaging indicates that this device should not be treated as unsorted municipal waste but should be collected separately.

Dispose of the device according to local guidelines and regulations. Use approved facilities and services for recycling electrical and electronic equipment.



The packaging is made up of environmentally friendly materials that may be disposed of through your local recycling facilities. By disposing of the packaging and packaging waste in a proper manner, you help in avoiding possible environment and public health hazards.

The symbol on the packaging indicates that the packaging is made of PAP.

This page is intentionally left blank

## 6 Troubleshooting



### Caution

#### Risk of injury!

The device must only be repaired by a qualified and trained person.

This section describes common troubleshooting solutions.

If the device is not operating correctly, please refer to the error codes, troubleshooting, and repair sections before contacting your local Cougartron supplier.

**Error:** OLED display illuminated, but no power at brush tip.

- **Cause:** Device malfunction.
- **Solution:**
  1. Remove the orange work cable and the black earth cable from the device.
  2. Check the output voltage with a multimeter – it should read between 10.5 -14 V. AC/DC depending on the function mode the device is in.
  3. If there is no current while the device is in work mode, please contact your local Cougartron distributor.

**Error:** OLED display illuminated, but no power at brush tip.

- **Cause:** Dirty device elements.
- **Solution:**
  1. Disassemble the wand from the work handle and the brush from the wand.
  2. Use a wire brush to clean the connections between the cleaned elements.
  3. Add copper grease to the threads of all the cleaned elements to improve the connection and keep out acidic residue.

**Error:** OLED display illuminated, but no power at brush tip.

- **Cause:** Dirty earth clamp.
- **Solution:**
  1. Use a multimeter to check the connection between the tip of the earth clamp and the device connector on the black earth cable.
  2. Clean the earth clamp of any acid residue or dirt. Use a wire brush to remove dirt.

3. Add copper grease to the threads of all cleaned elements to improve connection and keep out any acidic residue.

**Error:** OLED display illuminated, but no power at brush tip.

- **Cause:** Cable or cable connector malfunction.
- **Solution:**
  1. Remove the orange work cable and the black earth cable from the device.
  2. Use a multimeter to check the connection between the brush crimp and the device connector on the orange work cable.
  3. If no connection is detected, please contact your Cougartron distributor.

**Error:** Power switch is turned on, but the OLED display is not working.

- **Cause:** Device is switched off.
- **Solution:** Ensure that the power switch is turned to the ON position.

**Error:** Power switch is turned on, but the OLED display is not working.

- **Cause:** Device is not connected.
- **Solution:** Ensure that the power cord is connected to the power outlet.

**Error:** Power switch is turned on, but the OLED display is not working.

- **Cause:** Power outlet malfunction.
- **Solution:** Ensure that the power outlet is working correctly.

## 6.1 Error codes

If an error occurs, the device goes into standby mode and displays an error code.

Clear the error message by pressing the standby button. If the error message appears again, the problem has not been fixed and you should contact your local Cougartron supplier.

**Table 12 - Error codes**

Error no.	Cause	Solution
E01	No voltage detection from transformer	Check thermal breaker at the rear of the machine
E021	Over Temperature Protection	Allow the machine to cool for 10 minutes
E022	Over Temperature Protection	Allow the machine to cool for 10 minutes

---

<b>Error no.</b>	<b>Cause</b>	<b>Solution</b>
E023	Over Temperature Protection	Allow the machine to cool for 10 minutes
E03	Over Current Protection	Restart the machine, and try working again. If the fault occurs repeatedly, then the machine needs to be returned for service
E05	Over Current Protection	Restart the machine, and try working again. If the fault occurs repeatedly, then the machine needs to be returned for service

---

This page is intentionally left blank

## 7 Specifications

This section details the specifications of the device.

### 7.1 List of specifications

Parameter	Unit			
Part number	WELC1055	WELC1056	WELC1016	WELC1019
Model Name	Power 30	Power 30x	ProPlus	ProPlus
Application	Applicable for TIG, MIG and other weld types on stainless steel and aluminum surfaces.			
Input power	110-240 V AC 50/60Hz 6.3 A	110-240 V AC 50/60Hz 6.3 A	220-240 V AC 50/60Hz 8 A	110-130 V AC 50/60Hz 10 A
Output power	10.5-14 V AC/DC 30 A	10.5-14 V AC/DC 30 A	14 V AC/DC 50 A	14 V AC/DC 50 A
Duty cycle with normal manual working process (not automated)	100% at 30 A	100% at 30 A	100% at 50 A	100% at 50 A
Technical life span	10 years			
Weight device	6.5 kg (14.3 lbs)	6.5 kg (14.3 lbs)	7.1 kg (15.7 lbs)	7.1 kg (15.7 lbs)
Weight package				
Ambient storage temperature range	-50°C (-58°F) to +65°C (149°F)			
Relative Humidity (RH)	0 - 70%			
Ambient working temperature range	-15°C (5°F) to +40°C (104°F)			

## 7.2 Spare parts and part numbers

This section contains lists of common spare parts.

### 7.2.1 Weld cleaning device accessories

**Table 13 - Weld cleaning device accessories**

Code	Description	Power 30 / 30x	ProPlus
WELC2118	Cougartron lead with earth clamp 4 m (13 ft), 50 A	Yes	Yes
WELC2047	Cougartron handle lead, orange 4 m (13 ft), 50 A	Yes	Yes
WELC2122	Cougartron extension lead, orange 4 m (13 ft), 50 A	Yes	Yes
WELC2120	Cougartron extension lead, black 4 m (13 ft), 50 A	Yes	Yes
WELC3021	Copper grease 20 g (0.7oz)	Yes	Yes
WELC2404	Cougartron transport Bag 40 x 20 x 26.5 cm (16 x 8 x 10 inch)	Yes	Yes
WELC2064	Cougartron transport case	Yes	Yes
WELC5006	Foam insert for WELC2064	Yes	Yes

### 7.2.2 Weld cleaning brush

**Table 14 - Weld cleaning brush**

Code	Description	Power 30 / 30x	ProPlus
WELC3101	Powerbrush (M6, 30 A) - 10 pack	Yes	
WELC3146	Superbrush (M6, 50 A) - 10 pack		Yes

### 7.2.3 Weld cleaning brush accessories

**Table 15 - Weld cleaning brush accessories**

Code	Description	Power 30 / 30x	ProPlus
WELC2835	Fury fluid feed wand and shroud assembly with seal	Yes	Yes
WELC2879	CGT fluid feed wand and shroud assembly with seal 2 brush	Yes	Yes
WELC2226	Cougartron wand/twist shroud set (for 1x M6 brush)	Yes	Yes



Code	Description	Power 30 / 30x	ProPlus
WELC2227	Cougartron twist shroud (for WELC2235 wand)	Yes	Yes
WELC2188	Cougartron wand/twist shroud set (for 2x M6 brush)	No	Yes
WELC2235	Cougartron wand only (M6 universal)	Yes	Yes
WELC2572	Cougartron double brush twist shroud - spare	Yes	Yes

## 7.2.4 Weld cleaning fluids

Table 16 - Weld cleaning fluids

Code	Description	Power 30 / 30x	ProPlus
WELC3081	CGT-550 Weld Cleaning & Polishing Fluid - 1 L (1 qt)	Yes	Yes
WELC3048	CGT-550 Weld Cleaning & Polishing Fluid - 5L (1.3 Gal)	Yes	Yes
WELC3083	CGT-350 Weld Cleaning Fluid - 1 L (1 qt)	Yes	Yes
WELC3050	CGT-350 Weld Cleaning Fluid - 5 L (1.3 Gal)	Yes	Yes
WELC3165	CGT-N5 HyPerformance Neutralising Fluid - 500 ml (1 Pt)	Yes	Yes
WELC3158	CGT-N5 HyPerformance Neutralising Fluid - 5 L (1.3 Gal)	Yes	Yes

## 7.2.5 Weld cleaning fluid accessories

Table 17 - Weld cleaning fluid accessories

Code	Description	Power 30 / 30x	ProPlus
WELC2005	Acid pot 500 ml (1 Pt) with lid	Yes	Yes
WELC2149	Cougartron microfibre cloth - 40x40 cm (16 x 16 inch) (black)	Yes	Yes
WELC2201	Cougartron spray bottle with sprayer 0.5 L (1 Pt) (empty)	Yes	Yes
WELC2092	Cougartron sprayer for spray bottle - orange	Yes	Yes
WELC2253	Tap for 5 L (1.3 Gal) weld cleaning fluids	Yes	Yes

## 7.2.6 Marking sets and accessories

Table 18 - Marking sets and accessories

Code	Description	Power 30 / 30x	ProPlus
WELC4045	Cougartron Marking Set with case	Yes	Yes
WELC4040	Cougartron marking block with adaptor	Yes	Yes
WELC4029	Cougartron marking block without adaptor	Yes	Yes
WELC4025	Cougartron carbon felt 75x40x4,6 mm (2.9x1.5 x 0.18") (10 pcs)	Yes	Yes
WELC4033	Cougartron white felt 75x40x3 mm (2.9 x 1.5x0.1") (10 pcs)	Yes	Yes
WELC4026	Cougartron yellow fabric 75x40 mm (2.9 x1.5") (10 pcs)	Yes	Yes
WELC4002	Cougartron O-ring for std marking block (pack5)	Yes	Yes

## 7.2.7 Marking fluids

Table 19 - Marking fluids

Code	Description	Power 30 / 30x	ProPlus
WELC3115	Cougartron CGT-S1 Marking Fluid - 500 ml (1 pt)	Yes	Yes
WELC3116	Cougartron CGT-AL Marking Fluid - 500 ml (1 pt)	Yes	Yes
WELC3117	Cougartron CGT-MS Marking Fluid - 500 ml (1 pt)	Yes	Yes
WELC3118	Cougartron CGT-BR Marking Fluid - 500 ml (1 pt)	Yes	Yes
WELC3119	Cougartron CGT-CO Marking Fluid - 500 ml (1 pt)	Yes	Yes
WELC3133	Cougartron CGT-TI Marking Fluid - 500 ml (1 pt)	Yes	Yes
WELC3159	Cougartron CGT-SA Marking Fluid - 500 ml (1 pt)	Yes	Yes

## 7.2.8 Marking stencils and printers

Table 20 - Marking stencils and printers

Code	Description	Power 30 / 30x	ProPlus
WELC4007	Marking stencil - 40x75 mm (1.5 x 2.9")	Yes	Yes
WELC4008	Marking stencil - 60x100 mm (2.3 x 3.9")	Yes	Yes
WELC4009	Marking stencil - 100x150 mm (3.9 x 5.9")	Yes	Yes
WELC4113	Stencil: Cougartron with plastic frame 113x50 mm (4.4 x 1.9")	Yes	Yes
WELC4938	Brother Stencil Printer - TD-4520DN - 106mm tape	Yes	Yes
WELC4942	Brother Stencil Printer - TD-4410D - 106mm tape	Yes	Yes
WELC4021	106 mm x 100 m (4" x 330 Ft) Marking Roll	Yes	Yes
WELC4043	PT-D600VP Brother Label Printer 18-24 mm (¾ - 1") tapes	Yes	Yes
WELC4284	PT-E550WVP Brother Label Printer 18-24 mm (¾ - 1") tapes	Yes	Yes
WELC4014	Cougartron Stencil tape, 18 mm x 3 m (¾ inch x 9 ft)	Yes	Yes
WELC4015	Cougartron Stencil tape, 24 mm x 3m	Yes	Yes
WELC4339	PT-800 W Brother Label Printer 18-36 mm (¾ - 1 ½ inch) tape	Yes	Yes
WELC4016	Cougartron Stencil tape, 36 mm x 3 m (1 7/16 inch x 9 ft)	Yes	Yes

This page is intentionally left blank

# Index

## **A**

acid 10  
applications 25

## **B**

brush cleaning 35  
brushes 37  
    selection 26  
buttons 19

## **C**

care of device 37  
clean brushes 35  
clean function 19  
cleaning the device 35  
cleaning weld surfaces 26-27  
consumables 37  
Control panel 19  
copper grease 35

## **D**

device inspection 37  
device not working 44  
dimensions 17  
display 19  
disposal 41

## **E**

error codes 44

## **F**

finishing fluids 38  
fluids 38

**H**

handle 37

hardware overview 14

**I**

identify device 18

inspection 37

**L**

lifting the device 10

**M**

main parts 14

maintenance 37

marking and etching surfaces 32

marking fluids 38

marking surfaces 31

modes 25

monthly checks 37

**N**

neutralising fluids 38

**O**

OFF switch 16

OLED display illuminated, but no power at brush tip 43

ON switch 16

overview 25

owner responsibilities 11

**P**

packaging 41

parts replacement 37

polish function 19, 30

polishing surfaces 29-30

power down the device 24

power ratings 47

power switch 16

powering on the device 21

PPE requirements 7

## **R**

recycling parts 41

replacing parts 37

residual risk

- corrosive 10

- electrical 9

- heat 9

- heavy 10

- tripping 10

## **S**

safe operating area 8

safety labels 7

safety notices 5

select

- clean function 27

- marking 31

- mode for an application 25

- polish function 30

select a brush 26

serial number 18

shipping 21

shroud 37

shutting down the device 24

sizes 47

spare parts 39

specifications 47

standby 19

suggested settings for specific applications 25

## **T**

troubleshooting 43-44

turning on the device 21

twist shroud 37

## **U**

unpacking the device 21

using the device 25

## **W**

WEEE 41

weekly checks 37

weight 47

weld cleaning 26



This page is intentionally left blank



[www.cougartron.com](http://www.cougartron.com)

WELC6012 - 1.0